SECTION NINE

CONCRETE CONSTRUCTION

Edward S. Hoffman

*President, Edward S. Hoffman, Ltd.,
Structural Engineers, Chicago*

David P. Gustafson

*Vice President of Engineering
Concrete Reinforcing Steel Institute, Schaumburg, Illinois*

Economical, durable construction with concrete requires a thorough knowledge of its properties and behavior in service, of approved design procedures, and of recommended field practices. Not only is such knowledge necessary to avoid disappointing results, especially when concrete is manufactured and formed on the building site, but also to obtain maximum benefits from its unique properties.

To provide the needed information, several organizations promulgate standards, specifications, recommended practices, guides, and reports. Reference is made to these where appropriate throughout this section. Information provided herein is based on the latest available editions of the documents. Inasmuch as they are revised frequently, the latest editions should be used for current design and construction.

CONCRETE AND ITS INGREDIENTS

The American Concrete Institute "Building Code Requirements for Structural Concrete," ACI 318, contains the following basic definitions:

Concrete is a mixture of portland cement or any other hydraulic cement, fine aggregate, coarse aggregate, and water, with or without admixtures.

Admixture is a material other than hydraulic cement, aggregate, or water, used as an ingredient of concrete and added to concrete before or during its mixing to modify its properties.

In this section, unless indicated otherwise, these definitions apply to the terms concrete and admixture.

9.1 CEMENTITIOUS MATERIALS

The ACI 318 Building Code defines cementitious materials as those that have cementitious value when used in concrete either by themselves, such as portland

cement, blended hydraulic cements, or expansive cement, or in combination with fly ash (ASTM specification C618), raw or calcined natural pozzolans (ASTM C618), ground granulated blast-furnace slag (ASTM C989), or silica fume (ASTM C1240). Addition to a concrete mix of fly ash, silica fume, or slag decreases permeability, protects reinforcement, and increases strength. Concrete made with polymers, plastics with long-chain molecules, can have many qualities much superior to those of ordinary concrete. See also Sec. 4.

9.2 CEMENTS

The ACI 318 Building Code requires cement to conform to ASTM C150, "Standard Specification for Portland Cement;" or ASTM C595, "Standard Specification for Blended Hydraulic Cements;" or ASTM C845, "Standard Specification for Expansive Hydraulic Cement." Portland cements meeting the requirements of ASTM C150 are available in Types I to V and air-entraining Types IA to IIIA for use under different service conditions. The ACI 318 Building Code prohibits the use of slag cement, Types A and SA (ASTM C595), because these types are not intended as principal cementing constituents of structural concrete.

Although all the preceding cements can be used for concrete, they are *not* interchangeable. Note that both tensile and compressive strengths vary considerably, at early ages in particular, even for the five types of basic portland cement. Consequently, although project specifications for concrete strength f'_c are usually based on a standard 28-day age for the concrete, the proportions of ingredients required differ for each type. For concrete strengths up to 19,000 psi for columns in high-rise buildings, specified compressive strengths are usually required at 56 days after initial set of the concrete. For the usual building project, where the load-strength relationship is likely to be critical at a point in strength gain equivalent to 7-day standard curing (Fig. 9.1), substitution of a different type (sometimes brand) of cement without reportioning the mix may be dangerous.

The accepted specifications (ASTM) for cements do not regulate cement temperature nor color. Nevertheless, in hot-weather concreting, the temperature of the fresh concrete and therefore of its constituents must be controlled. Cement temperatures above 170°F are not recommended ("Hot Weathering Concreting," ACI 305R).

For exposed architectural concrete, not intended to be painted, control of color is desirable. For uniform color, the water-cement ratio and cement content must be kept constant, because they have significant effects on concrete color. Bear in mind that because of variations in the proportions of natural materials used, cements from different sources differ markedly in color. A change in brand of cement therefore can cause a change in color. Color differences also provoke a convenient check for substitution of types (or brands) of cement different from those used in trial batches made to establish proportions to be employed for a building.

9.3 AGGREGATES

Only material conforming to specifications for normal-weight aggregate (ASTM C33) or lightweight aggregate for structural concrete (ASTM C330) is accepted

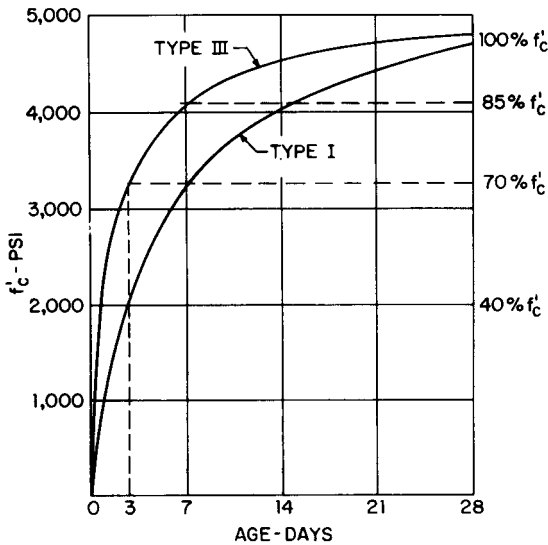

FIGURE 9.1 Typical strength-gain rate with standard curing of non-air-entrained concrete having a ratio of water to cementitious materials of 0.50.

under the ACI 318 Building Code without special tests. When an aggregate for which no experience record is available is considered for use, the modulus of elasticity and shrinkage as well as the compressive strength should be determined from trial batches of concrete made with the aggregate. In some localities, aggregates acceptable under C33 or C330 may impart abnormally low ratios of modulus of elasticity of strength (E_c/f'_c) or high shrinkage to concrete. Such aggregates should not be used.

9.4 PROPORTIONING CONCRETE MIXES

Principles for proportioning concrete to achieve a prescribed compressive strength after a given age under standard curing are simple.

1. The strength of a hardened concrete mix depends on the water-cementitious materials ratio (ratio of water to cementitious materials, by weight). The water and cementitious materials form a paste. If the paste is made with more water, it becomes weaker (Fig. 9.2).

2. The ideal minimum amount of paste is that which will coat all aggregate particles and fill all voids.

3. For practical purposes, fresh concrete must possess workability sufficient for the placement conditions. For a given strength and with given materials, the cost of the mix increases as the workability increases. Additional workability is provided by more fine aggregate and more water, but more cementitious materials must also be added to keep the same water-cementitious materials ratio.

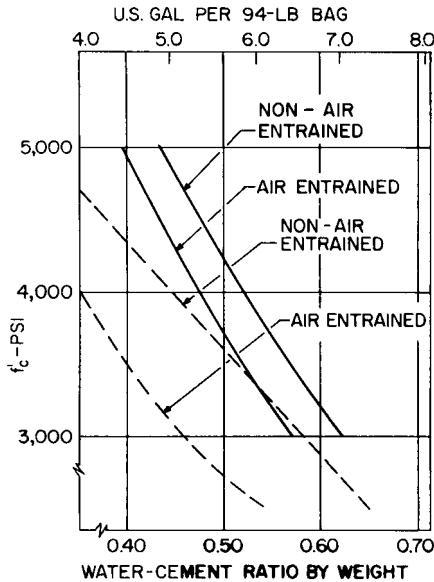

FIGURE 9.2 Curves show variation of 28-day compressive strength of normal-weight concrete with water-cementitious materials ratio. Solid lines indicate average results of tests. Dashed lines indicate relationship given in the ACI 318 Building Code for maximum permissible water-cementitious materials ratio and specified 28-day strengths.

Because of the variations in material constituents, temperature, and workability required at jobsites, theoretical approaches for determining ideal mix proportions usually do not give satisfactory results on the jobsite. Most concrete therefore is proportioned empirically, in accordance with results from trial batches made with the materials to be used on the jobsite. Small adjustments in the initial basic mix may be made as a project progresses; the frequency of such adjustments usually depends on the degree of quality control.

When new materials or exceptional quality control will be employed, the trial-batch method is the most reliable and efficient procedure for establishing proportions.

In determination of a concrete mix, past field experience or a series of trial batches is used to establish a curve relating the water-cementitious materials ratio to the strength and ingredient proportions of concrete, including admixtures if specified, for the range of desired strengths and workability (slump). Each point on the curve should represent the average test results on at least three specimens, and the curve should be determined by at least three points. Depending on anticipated quality control, a demonstrated or expected coefficient of variation or standard deviation is assumed for determination of minimum average strength of test specimens (Art. 9.10). Mix proportions are selected from the curve to produce this average strength.

For any large project, significant savings can be made through use of quality control to reduce the overdesign otherwise required by a building code (law). When

the owner's project specifications include a minimum content of cementitious materials, however, much of the economic incentive for the use of quality control is lost. See Fig. 9.3 for typical water-cementitious materials ratios.

Note that separate procedures are required for selecting proportions when lightweight aggregates are used, because their water-absorption properties differ from those of normal-weight aggregates.

("Building Code Requirements for Structural Concrete," ACI 318 "Standard Specifications for Structural Concrete," ACI 301; "Standard Practice for Selecting Proportions for Normal, Heavyweight, and Mass Concrete," ACI 211.1; "Standard Practice for Selecting Proportions for Structural Lightweight Concrete," ACI 211.2; "Recommended Practice for Evaluation of Strength Test Results of Concrete," ACI 214, American Concrete Institute, P.O. Box 9094, Farmington Hills, MI 48333, "Design and Control of Concrete Mixtures," EB001TC, Portland Cement Association, 5420 Old Orchard Road, Skokie, IL 60077.)

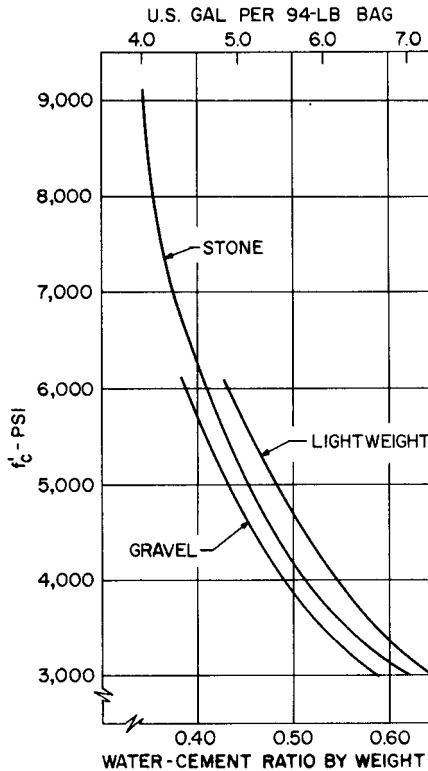

FIGURE 9.3 Curves show variation of 28-day compressive strength of non-air-entrained concrete with type of aggregate and water-cementitious materials ratio, except that strengths exceeding 7000 psi were determined at 56 days. All mixes contained a water-reducing agent and 100 lb/yd³ of fly ash. Calculation of water-cementitious materials ratio included two-thirds of the fly-ash weight in the cement content.

9.5 YIELD CALCULATION

Questions often arise between concrete suppliers and buyers regarding “yield,” or volume of concrete supplied. A major reason for this is that often the actual yield may be less than the yield calculated from the volumes of ingredients. For example, if the mix temperature varies, less air may be entrained; or if the sand becomes drier and no corrections in batch weights are made, the yield will be under that calculated.

If the specific gravity (sp. gr.) and absorption (abs.) of the aggregates have been determined in advance, accurate, yield calculations can be performed as often as necessary to adjust the yield for control of the concrete.

Example

Yield of Non-Air-Entrained Concrete. The following material properties were recorded for materials used in trial batches: fine aggregate (sand) sp. gr. = 2.65, abs. = 1%; coarse aggregate (gravel) sp. gr. = 2.70, abs. = 0.5%; and cement, sp. gr. = 3.15 (typical). These properties are not expected to change significantly as long as the aggregates used are from the same source. The basic mix proportions for 1 yd³ of concrete, selected from the trial batches are

Cement: 564 lb (6 bags)

Surface-dry sand: 1170 lb

Surface-dry gravel: 2000 lb

Free water: 300 lb/yd³ (36 gal/yd³)

Check the yield:

$$\text{Cement volume} = \frac{564}{3.15 \times 62.4} = 2.87 \text{ ft}^3$$

$$\text{Water volume} = 300/62.4 = 4.81 \text{ ft}^3$$

$$\text{Sand volume} = \frac{1170}{2.65 \times 62.4} = 7.08 \text{ ft}^3$$

$$\text{Gravel volume} = \frac{2000}{2.70 \times 62.4} = \underline{11.87 \text{ ft}^3}$$

$$\text{Total volume of solid constituents} = 26.63 \text{ ft}^3$$

$$\text{Volume of entrapped air} = 27 - 26.63 = 0.37 \text{ ft}^3 \text{ (1.4\%)}$$

$$\text{Total weight, lb/yd}^3 = 564 + 300 + 1170 + 2000 = 4034$$

$$\text{Total weight, lb/ft}^3 = 4034/27 = 149.4$$

$$\text{Weight of standard } 6 \times 12 \text{ in cylinder (0.1963 ft}^3) = 29.3 \text{ lb}$$

These results indicate that some rapid field checks should be made. Total weight, lb, divided by the total volume, yd³, reported on the trip tickets for truck mixers should be about 4000 on this project, unless a different slump was ordered and the

proportions adjusted accordingly. If the specified slump for the basic mix was to be reduced, weight, lb/yd^3 , should be increased, because less water and cement would be used and the cement paste (water plus cement) weighs $864/7.68 = 113 \text{ lb}/\text{ft}^3 < 149.4 \text{ lb}/\text{ft}^3$. If the same batch weights are used for all deliveries, and the slump varies erratically, the yield also will vary. For the same batch weights, a lower slump is associated with underyield, a higher slump with overyield. With a higher slump, overyield batches are likely to be understrength, because some of the aggregate has been replaced by water.

The basic mix proportions in terms of weights may be based on surface-dry aggregates or on oven-dry aggregates. The surface-dry proportions are somewhat more convenient, since absorption then need not be considered in calculation of free water. Damp sand and gravel carry about 5 and 1% free water, respectively. The total weight of this free water should be deducted from the basic mix weight of water ($300 \text{ lb}/\text{yd}^3$ in the example) to obtain the weight of water to be added to the cement and aggregates. The weight of water in the damp aggregates also should be added to the weights of the sand and gravel to obtain actual batch weights, as reported on truck-mixer delivery tickets.

9.6 PROPERTIES AND TESTS OF FRESH (PLASTIC) CONCRETE

About $2\frac{1}{2}$ gal of water can be chemically combined with each 94-lb sack of cement for full hydration and maximum strength. Water in excess of this amount will be required, however, to provide necessary workability.

Workability. Although concrete technologists define and measure workability and consistency separately and in various ways, the practical user specifies only one—slump (technically a measure of consistency). The practical user regards workability requirements simply as provision of sufficient water to permit concrete to be placed and consolidated without honeycomb or excessive water rise; to make concrete “pumpable” if it is to be placed by pumps; and for slabs, to provide a surface that can be finished properly. These workability requirements vary with the project and the placing, vibration, and finishing equipment used.

Slump is tested in the field very quickly. An open-ended, 12-in-high, truncated metal cone is filled in three equal-volume increments and each increment is consolidated separately, all according to a strict standard procedure (ASTM C143, “Slump of Hydraulic-Cement Concrete”). Slump is the sag of the concrete, in, after the cone is removed. The slump should be measured to the nearest $\frac{1}{4}$ in which is about the limit of accuracy reproducible by expert inspectors.

Unless the test is performed exactly in accordance with the standard procedure, the results are not comparable and therefore are useless.

The slump test is invalidated if: the operator fails to anchor the cone down by standing on the base wings; the test is performed on a wobbly base, such as form-work carrying traffic or a piece of metal on loose pebbles; the cone is not filled by inserting material in small amounts all around the perimeter, or filled and tamped in three equal increments; the top two layers are tamped deeper than their depth plus about 1 in; the top is pressed down to level it; the sample has been transported and permitted to segregate without remixing; unspecified operations, such as tap-

ping the cone, occur; the cone is not lifted up smoothly in one movement; the cone tips over because of filling from one side or pulling the cone to one side; or if the measurement of slump is not made to the center vertical axis of the cone.

Various penetration tests are quicker and more suitable for untrained personnel than the standard slump test. In each case, the penetration of an object into a flat surface of fresh concrete is measured and related to slump. These tests include use of the patented "Kelley ball" (ASTM C360, "Ball Penetration in Freshly Mixed Hydraulic Cement Concrete") and a simple, standard tamping rod with a bullet nose marked with equivalent inches of slump.

Air Content. A field test frequently required measures the air entrapped and entrained in fresh concrete. Various devices (air meters) that are available give quick, convenient results. In the basic methods, the volume of a sample is measured, then the air content is removed or reduced under pressure, and finally the remaining volume is measured. The difference between initial and final volume is the air content. (See ASTM C138, C173, and C231.)

Cement Content. Tests on fresh concrete sometimes are employed to determine the amount of cement present in a batch. Although performed more easily than tests on hardened concrete, tests on fresh concrete nevertheless are too difficult for routine use and usually require mobile laboratory equipment.

9.7 PROPERTIES AND TESTS OF HARDENED CONCRETE

The principal properties of concrete with which designers are concerned and symbols commonly used for some of these properties are:

- f'_c = specified compressive strength, psi, determined in accordance with ASTM C39 from standard 6- × 12-in cylinders under standard laboratory curing; unless otherwise specified, f'_c is based on tests on cylinders 28 days old
- E_c = modulus of elasticity, psi, determined in accordance with ASTM C469; usually assumed as $E_c = w^{1.5}(33)\sqrt{f'_c}$, or for normal-weight concrete (about 145 lb/ft³), $E_c = 57,000\sqrt{f'_c}$
- w = weight, lb/ft³, determined in accordance with ASTM C138 or C567
- f_t = direct tensile strength, psi
- f_{ct} = average splitting tensile strength, psi, of lightweight-aggregate concretes determined by the split cylinder test (ASTM C496)
- f_r = modulus of rupture, psi, the tensile strength at the extreme fiber in bending (commonly used for pavement design) determined in accordance with ASTM C78

Other properties, frequently important for particular conditions are: durability to resist freezing and thawing when wet and with deicers, color, surface hardness, impact hardness, abrasion resistance, shrinkage, behavior at high temperatures (about 500°F), insulation value at ordinary ambient temperatures, insulation at the high temperatures of a standard fire test, fatigue resistance, and for arctic construction, behavior at cold temperatures (-60 to -75°F). For most of the research on these properties, specially devised tests were employed, usually to duplicate or simulate the conditions of service anticipated. (See "Index to Proceedings of the American Concrete Institute.")

In addition to the formal testing procedures specified by ASTM and the special procedures described in the research references, some practical auxiliary tests, precautions in evaluating tests, and observations that may aid the user in practical applications follow.

Compressive Strength, f'_c . The standard test (ASTM C39) is used to establish the quality of concrete, as delivered, for conformance to specifications. Tests of companion field-cured cylinders measure the effectiveness of the curing (Art. 9.14).

Core tests (ASTM C42) of the hardened concrete in place, if they give strengths higher than the specified f'_c or an agreed-on percentage of f'_c (often 85%), can be used for acceptance of material, placing, consolidation, and curing. If the cores taken for these tests show unsatisfactory strength but companion cores given accelerated additional curing show strengths above the specified f'_c , these tests establish acceptance of the material, placing, and consolidation, and indicate the remedy, more curing, for the low in-place strengths.

For high-strength concretes, say above 5000 psi, care should be taken that the capping material is also high strength. Better still, the ends of the cylinders should be ground to plane.

Indirect testing for compressive strength includes surface-hardness tests (impact hammer). Properly calibrated, these tests can be employed to evaluate field curing. (See also Art. 9.14.)

Modulus of Elasticity E_c . This property is used in all design, but it is seldom determined by test, and almost never as a regular routine test. For important projects, it is best to secure this information at least once, during the tests on the trial batches at the various curing ages. An accurate value will be useful in prescribing camber or avoiding unusual deflections. An exact value of E_c is invaluable for long-span, thin-shell construction, where deflections can be large and must be predicted accurately for proper construction and timing removal of forms.

Tensile Strength. The standard splitting test is a measure of almost pure uniform tension f_{cr} . The beam test (Fig. 9.4a) measures bending tension f_r on extreme surfaces (Fig. 9.4b), calculated for an assumed perfectly elastic, triangular stress distribution.

The split-cylinder test (Fig. 9.4c) is used for structural design. It is not sensitive to minor flaws or the surface condition of the specimen. The most important application of the splitting test is in establishment of design values for reinforcing-steel development length, shear in concrete, and deflection of structural lightweight aggregate concretes.

The values of f_{cr} (Fig. 9.4d) and f_r bear some relationship to each other, but are not interchangeable. The beam test is very sensitive, especially to flaws on the surface of maximum tension and to the effect of drying-shrinkage differentials, even between the first and last of a group of specimens tested on the same day. The value f_r is widely used in pavement design, where all testing is performed in the same laboratory and results are then comparable.

Special Properties. Frequently, concrete may be used for some special purpose for which special properties are more important than those commonly considered. Sometimes, it may be of great importance to enhance one of the ordinary properties. These special applications often become apparent as new developments using new materials or as improvements using the basic materials. The partial list of special properties is constantly expanding—abrasion and impact resistance (heavy-duty floor surfacings), heat resistance (chimney stacks and jet engine dynamometer

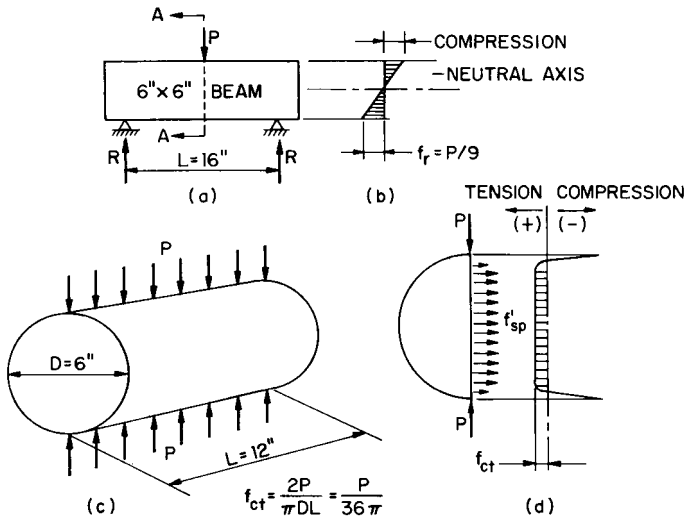

FIGURE 9.4 Test methods for tensile strength of concrete: (a) beam test determines modulus of rupture f_r ; (b) stress distribution assumed for calculation of f_r ; (c) split-cylinder test measures internal tension f_{ct} ; (d) stress distribution assumed for f_{ct} .

cells), light weight (concrete canoes), super-high-compressive strength, over ksi (high-rise columns), waterproof concrete, resistance to chemical attack (bridge decks, chemical industry floors, etc.), increased tensile strength (highway resurfacing, precast products, etc.), shrinkage-compensating concrete (grouting under base plates), etc. Some of these special properties are achieved with admixtures (see Art. 9.9). Some utilize special cements (high-alumina cement for heat resistance or expansive cement for shrinkage-compensating concrete). Some utilize special aggregates (lightweight aggregate, steel fiber, plastic fiber, glass fiber, and special heavy aggregate). (See "State-of-the-Art Report on Fiber Reinforced Concrete," ACI 544.1R). Some special properties—increased compressive and tensile strength, waterproofing, and improved chemical resistance are achieved with polymers, either as admixtures or surface treatment of hardened concrete. (See "Guide for the Use of Polymers in Concrete," ACI 548.1R.)

9.8 MEASURING AND MIXING CONCRETE INGREDIENTS

Methods of measuring the quantities and mixing the ingredients for concrete, and the equipment available, vary greatly. For very small projects where mixing is performed on the site, the materials are usually batched by volume. Under these conditions, accurate proportioning is very difficult. To achieve a reasonable minimum quality of concrete, it is usually less expensive to prescribe an excess of cement than to employ quality control. The same conditions make use of air-

entraining cement preferable to separate admixtures. This practical approach is preferable also for very small projects to be supplied with ready-mixed concrete. Economy with excess cement will be achieved whenever volume is so small that the cost of an additional sack of cement per cubic yard is less than the cost of a single compression test.

For engineered construction, some measure of quality control is always employed. In general, all measurements of materials including the cement and water should be by weight. The ACI 318 Building Code provides a sliding scale of overdesign for concrete mixes that is inversely proportional to the degree of quality control provided. In the sense used here, such overdesign is the difference between the specified f'_c and the actual average strength as measured by tests.

Mixing and delivery of structural concrete may be performed by a wide variety of equipment and procedures:

Site mixed, for delivery by chute, pump, truck, conveyor, or rail dump cars. (Mixing procedure for normal-aggregate concretes and lightweight-aggregate concretes to be pumped are usually different, because the greater absorption of some lightweight aggregates must be satisfied before pumping.)

Central-plant mixed, for delivery in either open dump trucks or mixer trucks.

Central-plant batching (weighing and measuring), for mixing and delivery by truck ("dry-batched" ready mix).

Complete portable mixing plants are available and are commonly used for large building or paving projects distant from established sources of supply.

Generally, drum mixers are used. For special purposes, various other types of mixers are required. These special types include countercurrent mixers, in which the blades revolve opposite to the turning of the drum, usually about a vertical axis, for mixing very dry, harsh, nonplastic mixes. Such mixes are required for concrete masonry or heavy-duty floor toppings. Dry-batch mixers are used for dry shotcrete (sprayed concrete), where water and the dry-mixed cement and aggregate are blended between the nozzle of the gun and impact at the point of placing.

("Guide for Measuring, Mixing, Transporting, and Placing Concrete," ACI 304R.)

9.9 ADMIXTURES

The ACI 318 Building Code requires prior approval by the engineer of admixtures to be used in concrete.

Air Entrainment. Air-entraining admixtures (ASTM C260) may be interground as additives with the cement at the mill or added separately at the concrete mixing plant, or both. Where quality control is provided, it is preferable to add such admixtures at the concrete plant so that the resulting air content can be controlled for changes in temperature, sand, or project requirements.

Use of entrained air is recommended for all concrete exposed to weathering or deterioration from aggressive chemicals. The ACI 318 Building Code requires air entrainment for all concrete subject to freezing temperatures while wet. Detailed recommendations for air content are available in "Standard Practice for Selecting

Proportions for Normal, Heavyweight, and Mass Concrete,” ACI 211.1, and “Standard Practice for Selecting Proportions for Structural Lightweight Concrete,” ACI 211.2.

One common misconception relative to air entrainment is the fear that it has a deleterious effect on concrete strength. Air entrainment, however, improves workability. This will usually permit some reduction in water content. For lean, low-strength mixes, the improved workability permits a relatively large reduction in water content, sand content, and water-cementitious materials ratio, which tends to increase concrete strength. The resulting strength gain offsets the strength-reducing effect of the air itself, and a net increase in concrete strength is achieved. For rich, high-strength mixes, the relative reduction in the ratio of water to cementitious materials, water-cementitious materials ratio, is lower and a small net decrease in strength results, about on the same order of the air content (4 to 7%). The improved durability and reduction of segregation in handling, because of the entrained air, usually make air entrainment desirable, however, in all concrete except extremely high-strength mixtures, such as for lower-story interior columns or heavy-duty interior floor toppings for industrial wear.

Accelerators. Calcium chloride for accelerating the rate of strength gain in concrete (ASTM D98) is perhaps the oldest application of admixtures. Old specifications for winter concreting or masonry work commonly required use of a maximum of 1 to 3% CaCl_2 by weight of cement for all concrete. Proprietary admixtures now available may include accelerators, but not necessarily CaCl_2 . The usual objective for use of an accelerator is to reduce curing time by developing 28-day strengths in about 7 days (ASTM C494).

In spite of users' familiarity with CaCl_2 , a number of misconceptions about its effect persist. It has been sold (sometimes under proprietary names) as an accelerator, a cement replacement, an “antifreeze,” a “waterproofing,” and a “hardener.” It is simply an accelerator; any improvement in other respects is pure serendipity. Experience, however, indicates corrosion damage from indiscriminate use of chloride-containing material in concrete exposed to stray currents, containing dissimilar metals, containing prestressing steel subject to stress corrosion, or exposed to severe wet freezing or salt water. The ACI 318 Building Code prohibits the use of calcium chloride or admixtures containing chloride from other than impurities from admixture ingredients in prestressed concrete, in concrete containing embedded aluminum, or in concrete cast against stay-in-place galvanized forms. The Code also prohibits the use of calcium chloride as an admixture in concrete that will be exposed to severe or very severe sulfate-containing solutions. For further information, see “Chemical Admixtures for Concrete,” ACI 212.3R.

Retarders. Unless proper precautions are taken, hot-weather concreting may cause “flash set,” plastic shrinkage, “cold joints,” or strength loss. Admixtures that provide controlled delay in the set of a concrete mix without reducing the rate of strength gain during subsequent curing offer inexpensive prevention of many hot-weather concreting problems. These (proprietary) admixtures are usually combined with water-reducing admixtures that more than offset the loss in curing time due to delayed set (ASTM C494). See “Hot Weathering Concreting,” ACI 305R, for further details on retarders, methods of cooling concrete materials, and limiting temperatures for hot-weathering concreting.

Superplasticizers. These admixtures, which are technically known as “high-range water reducers,” produce a high-slump concrete without an increase in mixing water. Slumps of up to 10 in. for a period of up to 90 min can be obtained. This

greatly facilitates placing concrete around heavy, closely spaced reinforcing steel, or in complicated forms, or both, and reduces the need for vibrating the concrete. It is important that the slump of the concrete be verified at the jobsite prior to the addition of the superplasticizer. This ensures that the specified water-cementitious materials ratio required for watertight impermeable concrete is in fact being achieved. The superplasticizer is then added to increase the slump to the approved level.

Waterproofing. A number of substances, such as stearates and oils, have been used as masonry-mortar and concrete admixtures for “waterproofing.” Indiscriminate use of such materials in concrete without extremely good quality control usually results in disappointment. The various water-repellent admixtures are intended to prevent capillarity, but most severe leakage in concrete occurs at honeycombs, cold joints, cracks, and other noncapillary defects. Concrete containing water-repellent admixtures also requires extremely careful continuous curing, since it will be difficult to rewet after initial drying.

Waterproof concrete can be achieved by use of high-strength concrete with a low water-cementitious materials ratio to reduce segregation and an air-entraining agent to minimize crack width. Also, good quality control and inspection is essential during the mixing, placing, and curing operations. Surface coatings can be used to improve resistance to water penetration of vertical or horizontal surfaces. For detailed information on surface treatments, see “Guide to Durable Concrete,” ACI 201.2R.

Cement Replacement. The term “cement replacement” is frequently misused in reference to chemical admixtures intended as accelerators or water reducers. Strictly, a cement replacement is a finely ground material, usually weakly cementitious (Art. 9.1), which combines into a cementlike paste replacing some of the cement paste to fill voids between the aggregates. The most common applications of these admixtures are for low-heat, low-strength mass concrete or for concrete masonry. In the former, they fill voids and reduce the heat of hydration; in the latter, they fill voids and help to develop the proper consistency to be self-standing as the machine head is lifted in the forming process. Materials commonly used are fly ash, silica fume, ground granulated blast-furnace slag, hydraulic lime, natural cement, and pozzolans.

Special-Purpose Admixtures. The list of materials used from earliest times as admixtures for various purposes includes almost everything from human blood to synthetic coloring agents.

Admixtures for coloring concrete are available in all colors. The oldest and cheapest is perhaps carbon black.

Admixtures causing expansion for use in sealing cracks or under machine bases, etc., include powdered aluminum and finely ground iron.

Special admixtures are available for use where the natural aggregate is alkali reactive, to neutralize this reaction.

Proprietary admixtures are available that increase the tensile strength or bond strength of concrete. They are useful for making repairs to concrete surfaces.

For special problems requiring concrete with unusual properties, detailed recommendations of “Chemical Admixtures for Concrete,” ACI 212.3R, and references it contains, may be helpful.

For all these special purposes, a thorough investigation of admixtures proposed is recommended. Tests should be made on samples containing various proportions for colored concrete. Strength and durability tests should be made on concrete to

be exposed to sunlight, freezing, salt, or any other job condition expected, and special tests should be made for any special properties required, as a minimum precaution.

QUALITY CONTROL

9.10 MIX DESIGN

Concrete mixes are designed with the aid of test records obtained from field experience with the materials to be used. When field test results are not available, other means of mix proportioning can be used as described in this article. In any case, the proportions of ingredients must be selected to produce, so that for any three test specimens, the average strength equals or exceeds the specified compressive strength f'_c and no individual strength test (average of two specimens) falls below f'_c by more than 500 psi.

The required average strength, f'_{cr} , depends on the standard deviation s expected. Strength data for determining the standard deviation can be considered suitable if they represent either a group of at least 30 consecutive tests representing materials and conditions of control similar to those expected or the statistical average for two groups totaling 30 or more tests. The tests used to establish standard deviation should represent concrete produced to meet a specified strength within 1000 psi of that specified for the work proposed. For a single group of consecutive test results, the standard deviation is calculated

$$s = \sqrt{\frac{(x_1 - \bar{x})^2 + (x_2 - \bar{x})^2 + (x_3 - \bar{x})^2 + \dots + (x_n - \bar{x})^2}{n - 1}} \quad (9.1)$$

where x_1, x_2, \dots, x_n = strength, psi, obtained in test of first, second, . . . , n th sample, respectively

$\frac{n}{n}$ = number of tests

\bar{x} = average strength, psi of n cylinders

For two groups of consecutive test results combined, the standard deviation is calculated

$$s = \sqrt{\frac{(n_1 - 1)(s_1)^2 + (n_2 - 1)(s_2)^2}{(n_1 + n_2 - 2)}} \quad (9.2)$$

where s_1, s_2 = standard deviation calculated from two test records, 1 and 2, respectively

n_1, n_2 = number of tests in each test record, respectively

(“Recommended Practice for Evaluation of Strength Test Results of Concrete,” ACI 214.)

The strength used as a basis for selecting proportions of a mix should exceed the required f'_c by at least the amount indicated in Table 9.1.

TABLE 9.1 Recommended Average Strengths of Test Cylinders for Selecting Proportions for Concrete Mixes

Range of standard deviation s , psi	Average strength f'_{cr} psi
Under 300	$f'_c + 400$
300–400	$f'_c + 550$
400–500	$f'_c + 700$
500–600	$f'_c + 900$
Over 600	$f'_c + 1200$

The values for f'_{cr} in Table 9.1 are the larger of the values calculated from Eqs. (9.3) and (9.4).

$$f'_{cr} = f'_c + 1.34 ks \tag{9.3}$$

$$f'_{cr} = f'_c + 2.23 ks - 500 \tag{9.4}$$

where $k = 1.00$ for 30 tests, 1.03 for 25, 1.08 for 20, and 1.16 for 15.

For an established supplier of concrete, it is very important to be able to document the value of s . This value is based on a statistical analysis in which Eq. (9.1) is applied to at least 30 consecutive tests, and Eq. (9.2) is applied to two groups of consecutive tests totaling at least 30 tests. These tests must represent similar materials and conditions of control not stricter than those to be applied to the proposed project. The lower the value of s obtained from the tests, the closer the average strength is permitted to be to the specified strength. A supplier is thus furnished an economic incentive, lower cementitious materials content, to develop a record of good control (low s). A supplier who does maintain such a record can, in addition, avoid the expenses of trial batches.

When no such production record exists, the required average strength f'_{cr} , can be determined from Table 9.2. Documentation of the required average strength must be established. The documentation should consist of field strength records or trial mixtures confirming that the proposed concrete proportions will produce an average compressive strength equal to or greater than f'_{cr} . Alternatively, when an acceptable

TABLE 9.2 Required Average Compressive Strength When Data Are Not Available to Establish a Standard Deviation

Specified compressive strength, f'_c , psi	Required average compressive strength, f'_{cr} , psi
Less than 3000	$f'_c + 1000$
3000 to 5000	$f'_c + 1200$
5000 to 10,000*	$f'_c + 1400$
Over 10,000 to 15,000*	$f'_c + 1800$

*From ACI 301 "Standard Specifications for Structural Concrete."

record of field test results is not available, the ACI 318 Building Code, with several restrictions, permits the use of trial batches as a basis for selecting initial proportions. This condition is likely to occur when new sources of cement or aggregate are supplied to an established plant, to a new facility, such as a portable plant on the site, or for the first attempt at a specified strength f'_c more than 1000 psi above previous specified strengths.

The ACI 318 Building Code includes provisions for proportioning concrete mixes based on other experience or information, if approved by the Engineer. This alternative procedure is restricted to proportioning concrete with a specified $f'_c \leq 4000$ psi. The required average compressive strength f'_{cr} must be at least 1200 psi greater than f'_c . Concrete proportioned by this procedure must also conform to the Code's durability requirements. These provisions are intended to allow the construction work to continue when there is an unexpected interruption in concrete supply and time does not permit tests and evaluation. These provisions are also aimed at small projects where the cost of trial batches is not justified.

The initially established proportions can be used during progress of a project only as long as the strength-test results justify them. The process of quality control of concrete for a project requires maintenance of a running average of strength-test results and changes in the proportions whenever the actual degree of control (standard deviation s) varies from that assumed for the initial proportioning. Equations (9.3) and (9.4) are applied for this analysis. With project specifications based on the ACI 318 Building Code, no minimum cementitious-materials content is required; so good control during a long-time project is rewarded by permission to use a lower cementitious-materials content than would be permitted with inferior control.

Regardless of the method used for proportioning the basic initial proportions should be based on mixes with both air content and slump at the maximum permitted by the project specifications.

TABLE 9.3 Required Air Entrainment in Concrete Exposed to Freezing and Thawing

Nominal maximum size of coarse aggregate, in.	Total air content, % by volume	
	Severe exposure	Moderate exposure
$\frac{3}{8}$	7½	6
$\frac{1}{2}$	7	5½
$\frac{3}{4}$	6	5
1	6	4½
1½	5½	4½
2	5	4
3	4½	3½

*From ACI 318-99, Table 4.2.1. for $f'_c > 5000$ psi, air content may be reduced 1%. "Severe exposure" is where concrete in a cold climate may be in almost continuous contact with moisture prior to freezing, or where deicing salts are used. "Moderate exposure" is where concrete in a cold climate will only be exposed to moisture prior to freezing and where no deicing salts are used.

Other ACI 318 Building Code requirements for mix design are:

1. Concrete exposed to freezing and thawing or to deicing chemicals while wet should have air entrained within the limits in Table 9.3, and the water-cementitious materials ratio by weight should not exceed 0.45. If lightweight aggregate is used, f'_c should be at least 4500 psi.

2. For watertight, normal-weight concrete, maximum water-cementitious materials ratios by weight are 0.50 for exposure to fresh water and 0.40 for seawater or deicing chemicals. With lightweight aggregate, minimum f'_c is 4000 psi for concrete exposed to fresh water and f'_c is 5000 psi for seawater or deicing chemicals.

Although the Code does not distinguish between a "concrete production facility" with in-house control and an independent concrete laboratory control service, the distinction is important. Very large suppliers have in-house professional quality control. Most smaller suppliers do not. Where the records of one of the latter might indicate a large standard deviation, but an independent quality-control service is utilized, the standard deviation used to select f'_{cr} should be based on the proven record of the control agency. Ideally, the overdesign should be based, in these cases, on the record of the control agency operating in the concrete plant used.

9.11 CHECK TESTS OF MATERIALS

Without follow-up field control, all the statistical theory involved in mixed proportioning becomes an academic exercise.

The complete description of initial proportions should include: cement analysis and source; specific gravity, absorption, proportions of each standard sieve size; fineness modulus; and organic tests for fine and coarse aggregates used, as well as their weights and maximum nominal sizes.

If the source of any aggregate is changed, new trial batches should be made. A cement analysis should be obtained for each new shipment of cement.

The aggregate gradings and organic content should be checked at least daily, or for each 150 yd³. The moisture content (or slump) should be checked continuously for all aggregates, and suitable adjustments should be made in batch weights. When the limits of ASTM C33 or C330 for grading or organic content are exceeded, proper materials should be secured and new mix proportions developed, or until these measurements can be effected, concrete production may continue on an emergency basis but with a penalty of additional cement.

9.12 AT THE MIXING PLANT— YIELD ADJUSTMENTS

Well-equipped concrete producers have continuous measuring devices to record changes in moisture carried in the aggregates or changes in total free water in the contents of the mixer. The same measurements, however, may be easily made manually by quality-control personnel.

To illustrate: for the example in Art. 9.5, the surface-dry basic mix is cement, 564 lb; water, 300 lb; sand, 1170 lb; and gravel, 2000 lb. Absorption is 1% for the

sand and 0.5% for the gravel. If the sand carries 5.5% and the gravel 1.0% total water by weight, the added free water becomes:

$$\text{Sand: } 1170 (0.055 - 0.01) = 53 \text{ lb}$$

$$\text{Gravel: } 2000 (0.010 - 0.005) = 10 \text{ lb}$$

Batch weights adjusted for yield become:

$$\text{Cement: } 564 \text{ lb}$$

$$\text{Water: } 300 - 53 - 10 = 237 \text{ lb}$$

$$\text{Sand: } 1170 + 53 = 1223 \text{ lb}$$

$$\text{Gravel: } 2000 + 10 = 2010 \text{ lb}$$

Note that the corrective adjustment includes adding to aggregate weights as well as deducting water weight. Otherwise, the yield will be low, and slump (slightly) increased. The yield would be low by about

$$\frac{53 + 10}{2.65 \times 62.4} = 0.381 \text{ ft}^3/\text{yd}^3 = 1.4\%$$

9.13 AT THE PLACING POINT— SLUMP ADJUSTMENTS

With good quality control, no water is permitted on the mixing truck. If the slump is too low (or too high) on arrival at the site, additional cement must be added. If the slump is too low (the usual complaint), additional water and cement in the prescribed water-cementitious materials ratio can also be added. After such additions, the contents must be thoroughly mixed, 2 to 3 min at high speed. Because placing-point adjustments are inconvenient and costly, telephone or radio communication with the supply plant is desirable so that most such adjustments may be made conveniently at the plant.

Commonly, a lesser degree of control is accepted in which the truck carries water, the driver is on the honor system not to add water without written authorization from a responsible agent at the site, and the authorization as well as the amounts added are recorded on the record (trip ticket) of batch weights.

Note: If site adjustments are made, test samples for strength-test specimens should be taken only after all site adjustments. For concrete in critical areas, such as lower-floor columns in high-rise buildings, strictest quality control is recommended.

9.14 STRENGTH TESTS

Generally, concrete quality is measured by the specified compressive strength f'_c of 6- × 12-in cylinders after 28 days of laboratory curing.

Conventional Tests. The strength tests performed after various periods of field curing are typically specified to determine curing adequacy. For lightweight-aggregate concretes only, the same type of laboratory-cured test specimen is tested for tensile splitting strength f_{ct} to establish design values for deflection, development of reinforcing steel, and shear. Applicable ASTM specifications for these tests are

C31, "Making and Curing Concrete Test Specimens in the Field."

C39, "Test for Compressive Strength of Cylindrical Concrete Specimens."

C496, "Test for Splitting Tensile Strength of Cylindrical Concrete Specimens."

The specifications for standard methods and procedures of testing give general directions within which the field procedures can be adjusted to jobsite conditions. One difficulty arises when the specimens are made in the field from samples taken at the jobsite. During the first 48 h after molding, the specimens are very sensitive to damage and variations from standard laboratory curing conditions, which can significantly reduce the strength-test results. Yet, jobsite conditions may preclude sampling, molding, and field storage on the same spot.

If the fresh-concrete sample must be transported more than about 100 ft to the point of molding cylinders, some segregation occurs. Consequently, the concrete sample should be remixed to restore its original condition. After the molds for test cylinders have been filled, if the specimens are moved, high-slump specimens segregate in the molds; low-slump specimens in the usual paper or plastic mold are often squeezed out of shape or separated into starting cracks. Such accidental damage varies with slump, temperature, time of set and molding, and degree of carelessness.

If the specimen cylinders are left on the jobsite, they must be protected against drying and accidental impact from construction traffic. If a worker stumbles over a specimen less than 3 days old, it should be inspected for damage. The best practice is to provide a small, insulated, dampproofed, locked box on the site in which specimens can be cast, covered, and provided with 60 to 80°F temperature and 100% humidity for 24 to 72 h. Then, they can be transported and subjected to standard laboratory curing conditions at the testing laboratory. When transported, the cylinders should be packed and handled like fresh eggs, since loose rattling will have about an equivalent effect in starting incipient cracks.

Similarly, conditions for field-cured cylinders must be created as nearly like those of the concrete in place as possible. Also, absolute protection against impact or other damage must be provided. Because most concrete in place will be in much larger elements than a test cylinder, most of the in-place concrete will benefit more from retained heat of hydration (Fig. 9.5). This effect decreases rapidly, because the rate of heat development is greatest initially. To ensure similar curing conditions, field-cured test cylinders should be stored for the first 24 h in the field curing box with the companion cylinders for laboratory curing. After this initial curing, the field-cured cylinders should be stored near the concrete they represent and cured under the same conditions.

Exceptions to this initial curing practice arise when the elements cast are of dimensions comparable to those of the cylinders, or the elements cast are not protected from drying or low temperatures, including freezing, or test cylinders are cured *inside* the elements they represent (patented system).

These simple, seemingly overmeticulous precautions will eliminate most of the unnecessary, expensive, project-delaying controversies over low tests. Both con-

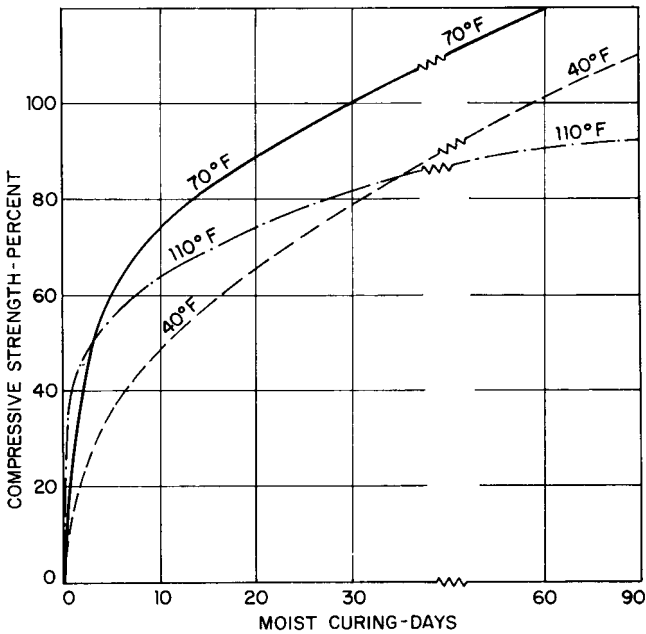

FIGURE 9.5 Effect of curing temperature on strength-gain rate of concrete, with 28-day strength as basis.

tractor and owner are justifiably annoyed when costly later tests on hardened concrete, after an even more costly project delay, indicate that the original fresh-concrete test specimens were defective and not the building concrete.

Special Tests. Many other strength tests or tests for special qualities are occasionally employed for special purposes. Those most often encountered in concrete building construction are strength tests on drilled cores and sawed beams (ASTM C42); impact tests (ASTM C805), e.g., Schmidt hammer; pullout tests (ASTM C900); penetration tests (ASTM C803); determination of modulus of elasticity during the standard compression test; and deflection measurements on a finished building element under load (Chap. 20, ACI 318-99). (See also “Commentary on ACI 318-99” and the “Manual of Concrete Inspection,” (ACI SP-2.)

Newer methods for evaluating in-situ strength of concrete include the following: Methods, such as the one in which test cylinders are field-cured inside the in-situ concrete, measure compressive strength directly, refined even to measuring it in a desired direction. Others actually measure other properties, such as penetration, impact, or pullout, which are indirect measures of compressive strength, but may be employed because the property they measure is itself important. For example, in cantilevered form construction where forms for each new lift are bolted into the previous lift, pullout results may be more meaningful than standard compression tests. (See “Testing Hardened Concrete,” ACI Monograph No. 9, 1976.) Most of the in-situ tests may also be classified as accelerated tests, although not all accelerated tests are performed in situ.

Because construction time is continually becoming a more important factor in overall construction economy, the standard 28-day strength becomes less significant.

For example, the final strength at completion of a high-rise project requiring high-strength concrete in lower-story columns is often specified 90-days. At the other extreme, a floor system may be loaded by the forms and concrete for the floor above in as little as 2 days. These conditions demand accelerated testing. (See “Standard Specifications for Structural Concrete,” ACI 301; and ASTM C684, “Standard Test Method for Making, Accelerated Curing, and Testing Concrete Compression Test Specimens.”)

9.15 TEST EVALUATION

On small projects, the results of tests on concrete after the conventional 28 days of curing may be valuable only as a record. In these cases, the evaluation is limited to three options: (1) accept results, (2) remove and replace faulty concrete, or (3) conduct further tests to confirm option (1) or (2) or for limited acceptance at a lower-quality rating. The same comment can be applied to a specific element of a large project. If the element supports 28 days' additional construction above, the consequences of these decisions are expensive.

Samples sufficient for at least five strength tests of each class of concrete should be taken at least once each day, or once for each 150 yd³ of concrete or each 5000 ft² of surface area placed. Each strength test should be the average for two cylinders from the same sample. The strength level of the concrete can be considered satisfactory if the averages of all sets of three consecutive strength-test results equal or exceed the specified strength f'_c and no individual strength-test result falls below f'_c by more than 500 psi.

If individual tests of laboratory-cured specimens produce strengths more than 500 psi below f'_c , steps should be taken to assure that the load-carrying capacity of the structure is not jeopardized. Three cores should be taken for each case of a cylinder test more than 500 psi below f'_c . If the concrete in the structure will be dry under service conditions, the cores should be air-dried (temperature 60 to 80°F, relative humidity less than 60%) for 7 days before the tests and should be tested dry. If the concrete in the structure will be more than superficially wet under service conditions, the cores should be immersed in water for at least 48 h and tested wet.

Regardless of the age on which specified design strength f'_c is based, large projects of the long duration offer the opportunity for adjustment of mix proportions during the project. If a running average of test results and deviations from the average is maintained, then, with good control, the standard deviation achieved may be reduced significantly below the usually conservative, initially assumed standard deviation. In that case, a saving in cement may be realized from an adjustment corresponding to the improved standard deviation. If control is poor, the owner must be protected by an increase in cement. Project specifications that rule out either adjustment are likely to result in less attention to quality control.

FORMWORK

For a recommended overall basis for project specifications and procedures, see “Guide to Formwork for Concrete,” ACI 347R. For materials, details, etc., for builders, see “Formwork for Concrete,” ACI SP-4. For requirements in project specifications, see “Standard Specifications for Structural Concrete, ACI 301.

9.16 RESPONSIBILITY FOR FORMWORK

The exact legal determination of responsibilities for formwork failures among owner, architect, engineer, general contractor, subcontractors, or suppliers can be determined only by a court decision based on the complete contractual arrangements undertaken for a specific project.

Generally accepted practice makes the following rough division of responsibilities:

Safety. The general contractor is responsible for the design, construction, and safety of formwork. Subcontractors or material suppliers may subsequently be held responsible to the general contractor. The term “safety” here includes prevention of any type of formwork failure. The damage caused by a failure always includes the expense of the formwork itself, and may also include personal injury or damage to the completed portions of a structure. Safety also includes protection of all personnel on the site from personal injury during construction. Only the supervisor of the work can control the workmanship in assembly and the rate of casting on which formwork safety ultimately depends.

Structural Adequacy of the Finished Concrete. The structural engineer is responsible for the design of the reinforced concrete structure. The reason for project specifications requiring that the architect or engineer approve the order and time of form removal, shoring, and reshoring is to ensure proper structural behavior during such removal and to prevent overloading of recently constructed concrete below or damage to the concrete from which forms are removed prematurely. The architect or engineer should require approval for locations of construction joints not shown on project drawings or project specifications to ensure proper transfer of shear and other forces through these joints. Project specifications should also require that debris be cleaned from form material and the bottom of vertical element forms, and that form-release agents used be compatible with appearance requirements and future finishes to be applied. None of these considerations, however, involves the safety of the formwork per se.

9.17 MATERIALS AND ACCESSORIES FOR FORMS

When a particular design or desired finish imposes special requirements, and only then, the engineer’s project specifications should incorporate these requirements and preferably require sample panels for approval of finish and texture. Under competitive bidding, best bids are secured when the bidders are free to use ingenuity and their available materials (“Formwork for Concrete,” ACI SP-4).

9.18 LOADS ON FORMWORK

Formwork should be capable of supporting safely all vertical and lateral loads that might be applied to it until such loads can be supported by the ground, the concrete structure, or other construction with adequate strength and stability. Dead loads on

formwork consist of the weight of the forms and the weight of and pressures from freshly placed concrete. Live loads include weights of workers, equipment, material storage, and runways, and accelerating and braking forces from buggies and other placement equipment. Impact from concrete placement also should be considered in formwork design.

Horizontal or slightly inclined forms often are supported on vertical or inclined support members, called shores, which must be left in place until the concrete placed in the forms has gained sufficient strength to be self-supporting. The shores may be removed temporarily to permit the forms to be stripped for reuse elsewhere, if the concrete has sufficient strength to support dead loads, but the concrete should then be reshored immediately. Loads assumed for design of shoring and reshoring of multistory construction should include all loads transmitted from the stories above as construction proceeds.

9.18.1 Pressure of Fresh Concrete on Vertical Forms

This pressure may be estimated from

$$p = 150 + 9000 \frac{R}{T} \quad (9.5)$$

where p = lateral pressure, psf
 R = rate of filling, ft/h
 T = temperature of concrete, °F

See Fig. 9.6a.

For columns, the maximum pressure p_{\max} is 3000 psf or $150h$, whichever is less, where h = height, ft, of fresh concrete above the point of pressure. For walls where R does not exceed 7 ft/h, $p_{\max} = 2000$ psf or $150h$, whichever is less.

For walls with rate of placement $R < 7$,

$$p = 150 + \frac{43,400}{T} + 2800 \frac{R}{T} \quad (9.6)$$

where $p_{\max} = 2000$ psf or $150h$, whichever is less. See Fig. 9.6b.

The calculated form pressures should be increased if concrete unit weight exceeds 150 pcf, cements are used that are slower setting than standard portland cement, slump is more than 4 in. with use of superplasticizers, retarders are used to slow set, the concrete is revibrated full depth, or forms are externally vibrated. Under these conditions, a safe design assumes that the concrete is a fluid with weight w and $p_{\max} = wh$ for the full height of placement.

9.18.2 Design Vertical Loads for Horizontal Forms

Best practice is to consider all known vertical loads, including the formwork itself, plus concrete, and to add an allowance for live load. This allowance, including workers, runways, and equipment, should be at least 50 psf. When concrete will be distributed from overhead by a bucket or by powered buggies, an additional allowance of at least 25 psf for impact load should be added. Note that the weight of a loaded power buggy dropping off a runway, or an entire bucket full of concrete

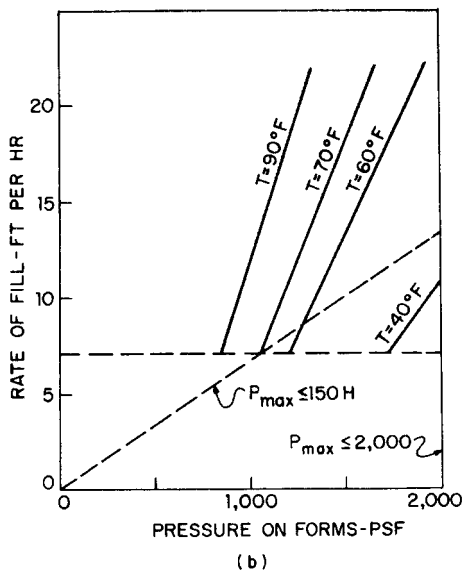
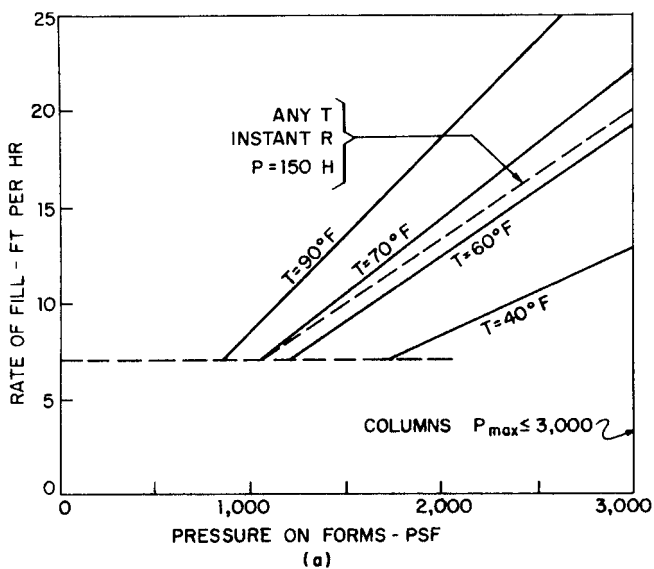

FIGURE 9.6 Internal pressures exerted by concrete on formwork: (a) column forms; (b) wall forms.

dropped at one spot, is not considered and might exceed designs based on 50- or 75-psf live load. Formwork should be designed alternatively, with continuity, to accept such spot overloads and distribute them to various unloaded areas, or with independently braced units to restrict a spot overload to a spot failure. The first alternative is preferable.

9.18.3 Lateral Loads for Shoring

Most failures of large formwork are “progressive,” vertically through several floors, or horizontally, as each successive line of shoring collapses like a house of cards. To eliminate all possibility of a large costly failure, the overall formwork shoring system should be reviewed before construction to avoid the usual “house-of-cards” design for vertical loads only. Although it is not always possible to foresee exact sources or magnitudes of lateral forces, shoring for a floor system should be braced to resist at least 100 lb/lin ft acting horizontally upon any of the edges, or a total lateral force on any edge equal to 2% of the total dead loads on the floor, whichever is larger.

Wall forms should be braced to resist local building-code wind pressures, plus at least 100 lb/lin ft at the top in either direction. The recommendation applies to basement wall forms even though wind may be less, because of the high risk of personal injury in the usual restricted areas for form watchers and other workers.

9.19 FORM REMOVAL AND RESHORING

Much friction between contractors’ and owners’ representatives is created because of misunderstanding of the requirements for form removal and reshoring. The contractor is concerned with a fast turnover of form reuse for economy (with safety), whereas the owner wants quality, continued curing for maximum in-place strength, and an adequate strength and modulus of elasticity to minimize initial deflection and cracking. Both want a satisfactory surface.

Satisfactory solutions for all concerned consist of the use of high-early-strength concrete or accelerated curing, or substitution of a means of curing protection other than formwork. The use of field-cured cylinders (Arts. 9.7 and 9.14) in conjunction with appropriate nondestructive in-place strength tests (Art. 9.14) enables owner and contractor representatives to measure the rate of curing to determine the earliest time for safe form removal.

Reshoring or ingenious formwork design that keeps shores separate from surface forms, such as “flying forms” that are attached to the concrete columns, permits early stripping without premature stress on the concrete. Properly performed, reshoring is ideal from the contractors’ viewpoint. But the design of reshores several stories in depth becomes very complex. The loads delivered to supporting floors are very difficult to predict and often require a higher order of structural analysis than that of the original design of the finished structure. To evaluate these loads, knowledge is required of the modulus of elasticity E_c of each floor (different), properties of the shores (complicated in some systems by splices), and the initial stress in the shores, where is dependent on how hard the wedges are driven or the number of turns of screw jacks, etc. (“Formwork for Concrete,” ACI SP-4). When stay-in-place shores are used, reshoring is simpler (because variations in initial

stress, which depend on workmanship, are eliminated), and a vertically progressive failure can be averted.

One indirect measure is to read deflections of successive floors at each stage. With accurate measurements of E_c , load per floor can then be estimated by structural theory. A more direct measure (seldom used) is strain measurement on the shores, usable with metal shores only. On large projects, where formwork cost and cost of failure justify such expense, both types of measurement can be employed.

9.20 SPECIAL FORMS

Special formwork may be required for uncommon structures, such as folded plates, shells, arches, and posttensioned-in-place designs, or for special methods of construction, such as slip forming with the form rising on the finished concrete or with the finished concrete descending as excavation progresses, permanent forms of any type, preplaced-grouted-aggregate concreting, underwater concreting, and combinations of precast and cast-in-place concreting.

9.21 INSPECTION OF FORMWORK

Inspection of formwork for a building is a service usually performed by the architect, engineer, or both, for the owner and, occasionally, directly by employees of the owner. Formwork should be inspected before the reinforcing steel is in place to ensure that the dimensions and location of the concrete conform to design drawings (Art. 9.16). This inspection would, however, be negligent if deficiencies in the areas of contractor responsibility were not noted also.

(See "Guide to Formwork for Concrete," ACI 347R, and "Formwork for Concrete," ACI SP-4, for construction check lists, and "Manual of Concrete Inspection," ACI SP-2.)

REINFORCEMENT

9.22 REINFORCING BARS

The term *deformed steel bars for concrete reinforcement* is commonly shortened to *rebars*. The short form will be used in this section.

Standard rebars are produced in 11 sizes, designated on design drawings and in project specifications by a size number. Since the late 1990's, bar producers have been manufacturing soft-metric rebars for use in both metric and inch-pound construction projects. Soft metric rebars have the same physical features as the corresponding inch-pound bars, i.e., the same nominal diameters and weight per foot (Table 9.4). Soft metric bars are marked with the metric size number and the metric grade of steel.

TABLE 9.4 ASTM Standard Rebars

Bar size no. ^a	Nominal dimensions ^b					
	Diameter mm [in.]		Cross-sectional area, mm ² [in. ²]		Weight kg/m [lbs/ft]	
10 [3]	9.5	[0.375]	71	[0.11]	0.560	[0.376]
13 [4]	12.7	[0.500]	129	[0.20]	0.994	[0.668]
16 [5]	15.9	[0.625]	199	[0.31]	1.552	[1.043]
19 [6]	19.1	[0.750]	284	[0.44]	2.235	[1.502]
22 [7]	22.2	[0.875]	387	[0.60]	3.042	[2.044]
25 [8]	25.4	[1.000]	510	[0.79]	3.973	[2.670]
29 [9]	28.7	[1.128]	645	[1.00]	5.060	[3.400]
32 [10]	32.3	[1.270]	819	[1.27]	6.404	[4.303]
36 [11]	35.8	[1.410]	1006	[1.56]	7.907	[5.313]
43 [14]	43.0	[1.693]	1452	[2.25]	11.38	[7.65]
57 [18]	57.3	[2.257]	2581	[4.00]	20.24	[13.60]

^aEquivalent inch-pound bar sizes are the designations enclosed within brackets.

^bThe equivalent nominal dimensions of inch-pound bars are the values enclosed within brackets.

Table 9.5 shows the bar sizes and strength grades covered by ASTM Specifications A615/A615M and A706/A706M.* The grade number indicates minimum yield strength, MPa [ksi] of the steel. Grade 420 [60] billet-steel rebars, conforming to ASTM A615/A615M, are currently the most widely used type.

Low-alloy steel rebars conforming to the ASTM A706/A706M Specification are intended for applications where controlled tensile properties are essential, for ex-

TABLE 9.5 Rebar Sizes and Grades Conforming to ASTM Specifications

Type of steel and ASTM specification	Bar size numbers	Grade*
Billet steel	10–19 [3–6]	300 [40]
A615/A615M	10–36, 43, 57 [3–11, 14, 18]	420 [60]
	19–36, 43, 57 [6–11, 14, 18]	520 [75]
Low-alloy steel	10–36, 43, 57 [3–11, 14, 18]	420 [60]
A706/A706M		

*Minimum yield strength.

*Many of the ASTM specifications for steel reinforcement are in a dual units format—metric units and inch-pound units. The designations of such specifications are also in a dual format, e.g., A615/A615M. The metric units in the specification apply when “A615M” is specified. Similarly, inch-pound units apply under “A615.”

Since rail-steel and axle steel reinforcing bars (ASTM A996/A996M) are not generally available except in a few areas of the country, these types of bars are not discussed herein. Should the need arise to evaluate or specify rail-steel or axle-steel bars, ASTM Specification A996/A996M should be reviewed.

ample, in earthquake-resistant design and construction. The A706/A706M Specification also includes requirements to enhance ductility and bendability. Rebars conforming to A706/A706M are also intended for welding. Weldability is accomplished by the specification's limits or controls on the chemical composition of the steel. Welding of rebars should conform to the requirements of "Structural Welding Code—Reinforcing Steel," ANSI/AWS D1.4.

Billet-steel rebars conforming to ASTM A615/A615M are not produced to meet weldability requirements. They may be welded, however, by complying with the requirements in ANSI/AWS D1.4.

Coated rebars, either epoxy-coated or zinc-coated (galvanized), are used where corrosion protection is desired in reinforced concrete structures. The ACI 318 Building Code requires epoxy-coated rebars to conform to ASTM Specifications A775/A775M or A934/A934M. Zinc-coated (galvanized) rebars are required to conform to ASTM A767/A767M.

ASTM Specification A955M for stainless steel rebars was published in 1996. Stainless steel rebars are intended for use in highly-corrosive environments, or in buildings which require non-magnetic steel reinforcement.

In 1997, ASTM issued Specification A970/A970M for headed reinforcing bars. A headed rebar consists of a head fastened or connected to one or both ends of a rebar. The head, which can be a rectangular or round steel plate, is connected to the rebar by welding or threading. Another type of headed rebar has an integrally-forged head. The purpose of the head is to provide end anchorage of the rebar in concrete. Headed rebars can be used advantageously in lieu of bars with standard end hooks thereby relieving congestion of reinforcement and enhancing constructability.

9.23 WELDED-WIRE FABRIC (WWF)

Welded-wire fabric is an orthogonal grid made with two kinds of cold-drawn wire: plain or deformed. The wires can be spaced in each direction of the grid as desired, but for buildings, usually at 12 in maximum. Sizes of wires available in each type, with standard and former designations, are shown in Table 9.6.

Welded-wire fabric usually is designated WWF on drawings. Sizes of WWF are designated by spacing followed by wire sizes; for example, WWF 6 × 12, W12/W8, which indicates plain wires, size W12, spaced at 6 in, and size W8, spaced at 12 in. WWF 6 × 12, D-12/D-8 indicated deformed wires of the same nominal size and spacing.

All WWF can be designed for Grade 60 material. Wire and welded-wire fabric are produced to conform with the following ASTM standard specifications:

ASTM A82, Plain Wire

ASTM A496, Deformed Wire

ASTM A185, Plain Wire, WWF

ASTM A497, Deformed Wire, WWF

Epoxy-coated wire and welded wire fabric are covered by the ASTM specification A884/A884M. Applications of epoxy-coated wire and WWF include use as corrosion-protection systems in reinforced concrete structures and reinforcement in reinforced-earth construction, such as mechanically-stabilized embankments.

TABLE 9.6 Standard Wire Sizes for Reinforcement

Size of deformed wire (A496)	Size of plain wire (A82)	Nominal dia, in.	Nominal area, in. ²	Size of deformed wire (A496)	Size of plain wire (A82)	Nominal dia, in.	Nominal area, in. ²
D-45	W45	0.757	0.450	D-12	W12	0.390	0.120
D-31	W31	0.628	0.310	D-11		0.374	0.110
D-30	W30	0.618	0.300	D-10	W10	0.356	0.100
D-29		0.608	0.290	D-9		0.338	0.090
D-28	W28	0.597	0.280	D-8	W8	0.319	0.080
D-27		0.586	0.270	D-7		0.298	0.070
D-26	W26	0.575	0.260	D-6	W6	0.276	0.060
D-25		0.564	0.250		W5.5	0.265	0.055
D-24	W24	0.553	0.240	D-5	W5	0.252	0.050
D-23		0.541	0.230		W4.5	0.239	0.045
D-22	W22	0.529	0.220	D-4	W4	0.225	0.040
D-21		0.517	0.210		W3.5	0.211	0.035
D-20	W20	0.504	0.200	D-3		0.195	0.030
D-19		0.491	0.190		W2.9	0.192	0.029
D-18	W18	0.478	0.180		W2.5	0.178	0.025
D-17		0.465	0.170	D2	W2	0.159	0.020
D-16	W16	0.451	0.160		W1.4	0.134	0.014
D-15		0.437	0.150		W1.2	0.124	0.012
D-14	W14	0.422	0.140	D-1		0.113	0.010
D-13		0.406	0.130		W0.5	0.080	0.005

9.24 PRESTRESSING STEEL

Cold-drawn high-strength wires, singly or stranded, with ultimate tensile strengths up to 270 ksi, and high-strength, alloy-steel bars, with ultimate tensile strengths up to 160 ksi, are used in prestressing. The applicable specifications are:

ASTM A416/A416M, Uncoated Seven-Wire Stress-Relieved Strand

ASTM A421/A421M, Uncoated Stress-Relieved Wire

ASTM A722/A722M, Uncoated High-Strength Bar

Single strands are used for plant-made pretensioned, prestressed members. Post-tensioned prestressing may be performed with the member in place, on a site fabricating area, or in a plant. Posttensioned tendons usually consist of strands or bars. Single wires, grouped into parallel-wire tendons, may also be used in posttensioned applications.

9.25 FABRICATION AND PLACING OF REBARS

Fabrication of rebars consists of cutting to length and required bending. The preparation of field placing drawings and bar lists is termed *detailing*. Ordinarily, the

rebar supplier details, fabricates, and delivers to the site, as required. In the far-western states, the rebar supplier also ordinarily places the bars. In the New York City area, fabrication is performed on the site by the same (union) workers who place the reinforcement. (See "Details and Detailing of Concrete Reinforcement," ACI 315).

Standard Hooks. The geometry and dimensions of standard hooks that conform to the ACI 318 Building Code and industry practice are shown in Table 9.7.

Fabrication Tolerances. These are covered in "Standard Specifications for Tolerances for Concrete Construction and Materials," ACI 117.

Shipping Limitations. Shipping widths or loading limits for a single bent bar and an L-shaped bar are shown in Fig. 9.7. Bundles of bars occupy greater space. The limit of 7 ft 4 in has been established as an industry practice to limit the bundle size to an 8-ft maximum load width. ("Manual of Standard Practice," Concrete Reinforcing Steel Institute.)

TABLE 9.7 Standard Hooks*

Bar size no.	Recommended end hooks—all grades of steel, in or ft-in			
	180° hooks			90° hooks
	D†	A or G	J	A or G
3	2¼	5	3	6
4	3	6	4	8
5	3¾	7	5	10
6	4½	8	6	1-0
7	5¼	10	7	1-2
8	6	11	8	1-4
9	9½	1-3	11¾	1-7
10	10¾	1-5	1-1¼	1-10
11	12	1-7	1-2¾	2-0
14	18¼	2-3	1-9¾	2-7
18	24	3-0	2-4½	3-5

† D = finished inside bend diameter, in.

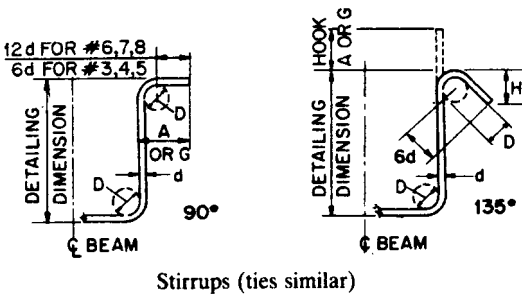
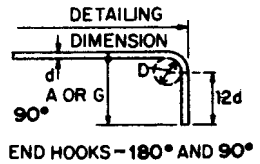
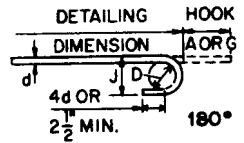

Stirrups (ties similar)

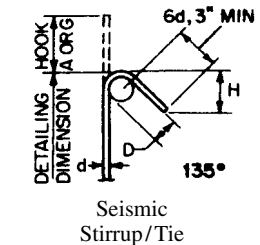

Seismic Stirrup/Tie

TABLE 9.7 Standard Hooks* (Continued)

Stirrup and tie hook dimensions, in or ft-in—all grades of steel					135° seismic stirrup/tie hook dimensions (ties similar) in.—all grades of steel			
Bar size no.	<i>D</i>	90° hook	135° hook		Bar size no.	<i>D</i>	135° hook	
		Hook <i>A</i> or <i>G</i>	Hook <i>A</i> or <i>G</i>	<i>H</i> , approx.			Hook <i>A</i> or <i>G</i>	<i>H</i> , approx.
3	1½	4	4	2½	3	1½	4¼	3
4	2	4½	4½	3	4	2	4½	3
5	2½	6	5½	3¾	5	2½	5½	3¾
6	4½	1-0	8	4½	6	4½	8	4½
7	5¼	1-2	9	5¼	7	5¼	9	5¼
8	6	1-4	10½	6	8	6	10½	6

* All specific sizes recommended by CRSI in this table meet minimum requirements of the ACI 318 Building Code.

Courtesy of the Concrete Reinforcing Steel Institute.

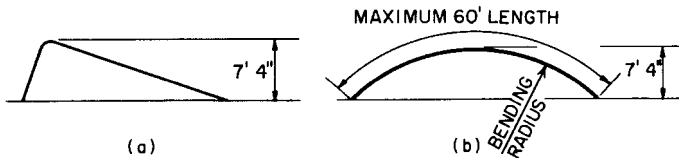

FIGURE 9.7 Shipping limitations: (a) height limit; (b) length and height limits.

Erection. For construction on small sites, such as high-rise buildings in metropolitan areas, delivery of materials is a major problem. Reinforcement required for each area to be concreted at one time is usually delivered separately. Usually, the only available space for storage of this reinforcing steel is the formwork in place. Under such conditions, unloading time becomes important.

The bars for each detail length, bar size, or mark number are wired into *bundles* for delivery. A *lift* may consist of one or more bundles grouped together for loading or unloading. The maximum weight of a single lift for unloading is set by the jobsite crane capacity. The maximum weight of a *shop lift* for loading is usually far larger, and so shop lifts may consist of several separately bundled *field lifts*. Regional practices and site conditions establish the maximum weight of bundles and lifts. Where site storage is provided, the most economical unloading without an immediately available crane is by dumping or rolling bundles off the side. Unloading arrangements should be agreed on in advance, so that loading can be carried out in the proper order and bars bundled appropriately. Care must be exercised during the unloading and handling of epoxy-coated rebars to minimize damage to the coating. (“Placing Reinforcing Bars,” CRSI.)

Placement Tolerances. The ACI 318 Building Code prescribes rebar placement tolerances applicable simultaneously to effective depth *d* and to concrete cover in all flexural members, walls, and columns as follows:

Where d is 8 in or less, $\pm 3/8$ in; more than 8 in $\pm 1/2$ in. The tolerance for the clear distance to formed soffits is $-1/4$ in. These tolerances may not reduce cover more than one-third of that specified. For additional information on tolerances, see "Standard Specifications for Tolerances for Concrete Construction and Materials," ACI 117.

Bundling. Rebars may be placed in concrete members singly or in bundles (up to four No. 11 or smaller bars per bundle). This practice reduces rebar congestion or the need for several layers of single, parallel bars in girders. For columns, it eliminates many interior ties and permits use of No. 11 or smaller bars where small quantities of No. 14 or No. 18 bars are not readily available.

Only straight bars should be bundled ordinarily. Exceptions are bars with end hooks, usually at staggered locations, so that the bars are not bent as a bundle ("Placing Reinforcing Bars," CRSI).

A bundle is assembled by wiring the separate bars tightly in contact. If they are preassembled, placement in forms of long bundles requires a crane. Because cutoffs or splices of bars within a bundle must be staggered, it will often be necessary to form the bundle in place.

Bending and Welding Limitations. The ACI 318 Building Code contains the following restrictions:

All bars must be bent without heating, except as permitted by the engineer.

Bars partly embedded in hardened concrete may not be bent without permission of the engineer.

No welding of crossing bars (tack welding) is permitted without the approval of the engineer.

For unusual bends, heating may be permitted because bars bend more easily when heated. If not embedded in thin sections of concrete, heating the bars to a maximum temperature of 1500°F facilitates bending, usually without damage to the bars or splitting of the concrete. If partly embedded bars are to be bent, heating controlled within these limits, plus the provision of a round fulcrum for the bend to avoid a sharp kink in the bar, are essential.

Tack welding creates a *metallurgical notch effect*, seriously weakening the bars. If different size bars are tacked together, the notch effect is aggravated in the larger bar. Tack welding therefore should never be permitted at a point where bars are to be fully stressed, and never for the assembly of ties or spirals to column verticals or stirrups to main beam bars.

When large, preassembled reinforcement units are desired, the engineer can plan the tack welding necessary as a supplement to wire ties at points of low stress or to added bars not required in the design.

9.26 BAR SUPPORTS

Bar supports are commercially available in three general types of material: wire, precast concrete, and all-plastic. Descriptions of the various types of bar supports,

as well as recommended maximum spacings and details for use, are given in the CRSI "Manual for Standard Practice."

Wire bar supports are generally available in the United States in three classes of rust prevention: plastic-protected, stainless-steel-protected, and no protection (plain). Precast-concrete bar supports are normally supplied in three styles; plain block, block with embedded wires, and block with a hole for the leg of a vertical bar for top- and bottom-bar support.

Various types and sizes of all-plastic bar supports and sideform spacers are available. Consideration should be given to the effects of thermal changes, inasmuch as the coefficient of thermal expansion of the plastic can differ significantly from that of concrete. Investigation of this property is advisable before use of all-plastic supports in concrete that will be exposed to high variations in temperature.

Bar supports for use with epoxy-coated rebars should be made of dielectric material. Alternatively, wire bar supports should be coated with dielectric material, such as plastic or epoxy.

9.27 INSPECTION OF REINFORCEMENT

This involves approval of rebar material for conformance to the physical properties required, such as ASTM specifications for the strength grade specified; approval of the bar details and placing drawings; approval of fabrication to meet the approved details within the prescribed tolerances; and approval of rebar placing.

Approvals of rebar material may be made on the basis of mill tests performed by the manufacturer for each heat from which the bars used originated. If samples are to be taken for independent strength tests, measurements of deformations, bending tests, and minimum weight, the routine samples may be best secured at the mill or the fabrication shop before fabrication. Occasionally, samples for check tests are taken in the field; but in this case, provision should be made for extra lengths of bars to be shipped and for schedules for the completion of such tests before the material is required for placing. Sampling at the point of fabrication, before fabrication, is recommended.

Inspection of fabrication and placement is usually most conveniently performed in the field, where gross errors would require correction in any event.

Under the ACI 318 Building Code, the bars should be free of oil, paint, form coatings, and mud when placed. Rust or mill scale sufficiently loose to damage the bond is normally dislodged in handling.

If heavily rusted bars (which may result from improper storage for a long time exposed to rusting conditions) are discovered at the time of placing, a quick field test of suitability requires only scales, a wire brush, and calipers. In this test, a measured length of the bar is wire-brushed manually and weighed. If less than 94% of the nominal weight remains, or if the height of the deformations is deficient, the rust is deemed excessive. In either case, the material may then be rejected or penalized as structurally inadequate. Where space permits placing additional bars to make up the structural deficiency (in anchorage capacity or weight), as in walls and slabs, this solution is preferred, because construction delay then is avoided. Where project specifications impose requirements on rust more severe than the structural requirements of the ACI 318 Building Code, for example, for decorative surfaces exposed to weather, the inspection should employ the special criteria required.

CONCRETE PLACEMENT

9.28 GOOD PRACTICE

The principles governing proper placement of concrete are:

Segregation must be avoided during all operations between the mixer and the point of placement, including final consolidation and finishing.

The concrete must be thoroughly consolidated, worked solidly around all embedded items, and should fill all angles and corners of the forms.

Where fresh concrete is placed against or on hardened concrete, a good bond must be developed.

Unconfined concrete must not be placed under water.

The temperature of fresh concrete must be controlled from the time of mixing through final placement, and protected after placement.

(“Guide for Measuring, Mixing, Transporting, and Placing Concrete,” ACI 304R; “Standard Specifications for Structural Concrete,” ACI 301; “Guide for Concrete Floor and Slab Construction,” ACI 302.1R.)

9.29 METHODS OF PLACING

Concrete may be conveyed from a mixer to point of placement by any of a variety of methods and equipment, if properly transported to avoid segregation. Selection of the most appropriate technique for economy depends on jobsite conditions, especially project size, equipment, and the contractor’s experience. In building construction, concrete usually is placed with hand- or power-operated buggies; drop-bottom buckets with a crane; inclined chutes; flexible and rigid pipe by pumping; *shotcrete*, in which either dry materials and water are sprayed separately or mixed concrete is shot against the forms; and for underwater placing, tremie chutes (closed flexible tubes). For mass-concrete construction, side-dump cars on narrow-gage track or belt conveyers may be used. For pavement, concrete may be placed by bucket from the swinging boom of a paving mixer, directly by dump truck or mixer truck, or indirectly by trucks into a spreader.

A special method of placing concrete suitable for a number of unusual conditions consists of grout-filling preplaced coarse aggregate. This method is particularly useful for underwater concreting, because grout, introduced into the aggregate through a vertical pipe gradually lifted, displaces the water, which is lighter than the grout. Because of bearing contact of the aggregate, less than usual overall shrinkage is also achieved.

9.30 EXCESS WATER

Even within the specified limits on slump and water-cementitious materials ratio, excess water must be avoided. In this context, excess water is present for the con-

ditions of placing if evidence of water rise (vertical segregation) or water flow (horizontal segregation) occurs. Excess water also tends to aggravate surface defects by increased leakage through form openings. The result may be honeycomb, sand-streaks, variations in color, or soft spots at the surface.

In vertical formwork, water rise causes weak planes between each layer deposited. In addition to the deleterious structural effect, such planes, when hardened, contain voids through which water may pass.

In horizontal elements, such as floor slabs, excess water rises and causes a weak laitance layer at the top. This layer suffers from low strength, low abrasion resistance, high shrinkage, and generally poor quality.

9.31 CONSOLIDATION

The purpose of consolidation is to eliminate voids of entrapped air and to ensure intimate complete contact of the concrete with the surfaces of the forms and the reinforcement. Intense vibration, however, may also reduce the volume of desirable entrained air; but this reduction can be compensated by adjustment of the mix proportions.

Powered internal vibrators are usually used to achieve consolidation. For thin slabs, however, high-quality, low-slump concrete can be effectively consolidated, without excess water, by mechanical surface vibrators. For precast elements in rigid, watertight forms, external vibration (of the form itself) is highly effective. External vibration is also effective with in-place forms, but should not be used unless the formwork is specially designed for the temporary increase in internal pressures to full fluid head plus the impact of the vibrator ("Guide to Formwork for Concrete," ACI 347R).

Except in certain paving operations, vibration of the reinforcement should be avoided. Although it is effective, the necessary control to prevent overvibration is difficult. Also, when concrete is placed in several lifts of layers, vibration of vertical rebars passing into partly set concrete below may be harmful. Note, however, that revibration of concrete before the final set, under controlled conditions, can improve concrete strength markedly and reduce surface voids (bugholes). This technique is too difficult to control for general use on field-cast vertical elements, but it is very effective in finishing slabs with powered vibrating equipment.

Manual spading is most efficient for removal of entrapped air at form surfaces. This method is particularly effective where smooth impermeable form material is used and the surface is upward sloping.

On the usual building project, different conditions of placement are usually encountered that make it desirable to provide for various combinations of the techniques described. One precaution generally applicable is that the vibrators not be used to move the concrete laterally.

("Guide for Consolidation of Concrete," ACI 309R.)

9.32 CONCRETING VERTICAL ELEMENTS

The interior of columns is usually congested; it contains a large volume of reinforcing steel compared with the volume of concrete, and has a large height com-

pared with its cross-sectional dimensions. Therefore, though columns should be continuously cast, the concrete should be placed in 2- to 4-ft-deep increments and consolidated with internal vibrators. These should be lifted after each increment has been vibrated. If delay occurs in concrete supply before a column has been completed, every effort should be made to avoid a cold joint. When the remainder of the column is cast, the first increment should be small, and should be vibrated to penetrate the previous portion slightly.

In all columns and reinforced narrow walls, concrete placing should begin with 2 to 4 in of grout. Otherwise, loose stone will collect at the bottom, resulting in the formation of honeycomb. This grout should be proportioned for about the same slump as the concrete or slightly more, but at the same or lower water-cementitious material ratio. (Some engineers prefer to start vertical placement with a mix having the same proportions of water, cement, and fine aggregate, but with one-half the quantity of coarse aggregate, as in the design mix, and to place a starting layer 6 to 12 in deep.)

When concrete is placed for walls, the only practicable means to avoid segregation is to place no more than a 24-in layer in one pass. Each layer should be vibrated separately and kept nearly level.

For walls deeper than 4 ft, concrete should be placed through vertical, flexible trunks or chutes located about 8 ft apart. The trunks may be flexible or rigid, and come in sections so that they can be lifted as the level of concrete in place rises. The concrete should not fall free, from the end of the trunk, more than 4 ft or segregation will occur, with the coarse aggregate ricocheting off the forms to lodge on one side. Successive layers after the initial layer should be penetrated by internal vibrators for a depth of about 4 to 6 in to ensure complete integration at the surface of each layer. Deeper penetration can be beneficial (revibration), but control under variable jobsite conditions is too uncertain for recommendation of this practice for general use.

The results of poor placement in walls are frequently observed: sloping layer lines; honeycombs, leaking, if water is present; and, if cores are taken at successive heights, up to a 50% reduction in strength from bottom to top. Some precautions necessary to avoid these ill effects are:

Place concrete in level layers through closely spaced trunks or chutes.

Do not place concrete full depth at each placing point.

Do not move concrete laterally with vibrators.

For deep, long walls, reduce the slump for upper layers 2 to 3 in below the slump for the starting layer.

On any delay between placing of layers, vibrate the concrete thoroughly at the interface.

If concreting must be suspended between planned horizontal construction joints, level off the layer cast, remove any laitance and excess water, and make a straight, level construction joint, if possible, with a small cleat attached to the form on the exposed face (see also Art. 9.39).

9.33 CONCRETING HORIZONTAL ELEMENTS

Concrete placement in horizontal elements follows the same general principles outlined in Art. 9.32. Where the surface will be covered and protected against abrasion and weather, few special precautions are needed.

For concrete slabs, careless placing methods result in horizontal segregation, with desired properties in the wrong location, the top consisting of excess water and fines with low abrasion and weather resistance, and high shrinkage. For a good surface in a one-course slab, low-slump concrete and a minimum of vibration and finishing are desirable. Immediate screeding with a power-vibrated screed is helpful in distributing low-slump, high-quality concrete. No further finishing should be undertaken until free water, if any, disappears. A powered, rotary tamping float can smooth very-low-slump concrete at this stage. Final troweling should be delayed, if necessary, until the surface can support the weight of the finisher.

When concrete is placed for deep beams that are monolithic with a slab, the beam should be filled first. Then, a short delay for settlement should ensue before slab concrete is cast. Vibration through the top slab should penetrate the beam concrete sufficiently to ensure thorough consolidation.

When a slab is cast, successive batches of concrete should be placed on the edge of previous batches, to maintain progressive filling without segregation. For slabs with sloping surfaces, concrete placing should usually begin at the lower edge.

For thin shells in steeply sloping areas, placing should proceed downslope. Slump should be adjusted and finishing coordinated to prevent restraint by horizontal reinforcing bars from causing plastic cracking in the fresh concrete.

9.34 BONDING TO HARDENED CONCRETE

The surface of hardened concrete should be rough and clean where it is to be bonded with fresh concrete.

Vertical surfaces of planned joints may be prepared easily by wire brushing them, before complete curing, to expose the coarse aggregate. (The timing can be extended, if desired, by using a surface retarder on the bulkhead form.) For surfaces fully cured without earlier preparation, sandblasting, bush hammering, or acid washes (thoroughly rinsed off) are effective means of preparation for bonding new concrete. (See also Art. 9.33.)

Horizontal surfaces of previously cast concrete, for example, of walls, are similarly prepared. Care should be taken to remove all laitance and to expose sound concrete and coarse aggregate. (See also Art. 9.32. For two-course floors, see Art. 9.35.)

9.35 HEAVY-DUTY FLOOR FINISHES

Floor surfaces highly resistant to abrasion and impact are required for many industrial and commercial uses. Such surfaces are usually built as two-course construction, with a base or structural slab topped by a wearing surface. The two courses may be cast integrally or with the heavy-duty surface applied as a separate topping.

In the first process, which is less costly, ordinary structural concrete is placed and screeded to nearly the full depth of the floor. The wearing surface concrete, made with special abrasion-resistant aggregate, emery, iron fillings, etc., then is mixed, spread to the desired depth, and troweled before final set of the concrete below.

The second method requires surface preparation of the base slab, by stiff brooming before final set to roughen the surface and thorough washing before the separate heavy-duty topping is cast. For the second method, the topping is a very dry (zero-slump) concrete, made with $\frac{3}{8}$ -in maximum-size special aggregate. This topping should be designed for a minimum strength, $f'_c = 6000$ psi. It must be tamped into place with powered tampers or rotary floats. (*Note:* If test cylinders are to be made from this topping, standard methods of consolidation will not produce a proper test; tamping similar in effect to that applied to the floor itself is necessary.) One precaution vital to the separate topping method is that the temperatures of topping and base slab must be kept compatible.

(“Guide for Concrete Floor and Slab Construction,” ACI 302.1R.)

9.36 CONCRETING IN COLD WEATHER

Frozen materials should never be used. Concrete should not be cast on a frozen subgrade, and ice must be removed from forms before concreting. Concrete allowed to freeze wet, before or during early curing, may be seriously damaged. Furthermore, temperatures should be kept above 40°F for any appreciable curing (strength gain).

Concrete suppliers are equipped to heat materials and to deliver concrete at controlled temperatures in cold weather. These services should be utilized.

In very cold weather, for thin sections used in buildings, the freshly cast concrete must be enclosed and provided with temporary heat. For more massive sections or in moderately cold weather, it is usually less expensive to provide insulated forms or insulated coverings to retain the initial heat and subsequent heat of hydration generated in the concrete during initial curing.

The curing time required depends on the temperature maintained and whether regular or high-early-strength concrete is used. High-early-strength concrete may be achieved with accelerating admixtures (Art. 9.9) or with high-early-strength cement (Types III or IIIA) or by a lower water-cementitious materials ratio, to produce the required 28-day strength in about 7 days.

An important precaution in using heated enclosures is to supply heat without drying the concrete or releasing carbon dioxide fumes. Exposure of fresh concrete to drying or fumes results in chalky surfaces. Another precaution is to avoid rapid temperature changes of the concrete surfaces when heating is discontinued. The heat supply should be reduced gradually, and the enclosure left in place to permit cooling to ambient temperatures gradually, usually over a period of at least 24 h.

(“Cold Weather Concreting,” ACI 306R; “Standard Specification for Cold Weather Concreting,” ACI 306.1; and “Standard Specifications for Structural Concrete,” ACI 301.)

9.37 CONCRETING IN HOT WEATHER

Mixing and placing concrete at a high temperature may cause *flash set* in the mixer, during placing, or before finishing can be completed. Also, loss of strength can result from casting hot concrete.

In practice, most concrete is cast at about $70 \pm 20^\circ\text{F}$. Research on the effects of casting temperature shows highest strengths for concrete cast at 40°F and significant but practically unimportant increasing loss of strength from 40°F to 90°F . For higher temperatures, the loss of strength becomes important. So does increased shrinkage. The increased shrinkage is attributable not only to the high temperature, but also to the increased water content required for a desired slump as temperature increases. See Fig. 9.5.

For ordinary building applications, concrete suppliers control temperatures of concrete by cooling the aggregates and, when necessary, by supplying part of the mixing water as crushed ice. In very hot weather, these precautions plus sectional casting, to permit escape of the heat of hydration, may be required for massive foundation mats. Retarding admixtures are also used with good effect to reduce slump loss during placing and finishing.

(“Hot Weather Concreting,” ACI 305R; and “Standard Specifications for Structural Concrete,” ACI 301.)

9.38 CURING CONCRETE

Curing of concrete consists of the processes, natural and artificially created, that affect the extent and rate of hydration of the cement.

Many concrete structures are cured without artificial protection of any kind. They are allowed to harden while exposed to sun, wind, and rain. This type of curing is unreliable, because water may evaporate from the surface.

Various means are used to cure concrete by controlling its moisture content or its temperature. In practice, curing consists of conserving the moisture within newly placed concrete by furnishing additional moisture to replenish water lost by evaporation. Usually, little attention is paid to temperature, except in winter curing and steam curing.

Most effective curing is beneficial in that it makes the concrete more watertight and increases the strength.

Methods for curing may be classified as:

1. Those that supply water throughout the early hydration process and tend to maintain a uniform temperature. These methods include ponding, sprinkling, and application of wet burlap or cotton mats, wet earth, sawdust, hay, or straw.
2. Those designed to prevent loss of water but having little influence on maintaining a uniform temperature. These methods include waterproof paper and impermeable membranes. The latter is usually a clear or bituminous compound sprayed on the concrete to fill the pores and thus prevent evaporation. A fugitive dye in the colorless compound aids the spraying and inspection.

A white pigment that gives infrared reflectance can be used in a curing compound to keep concrete surfaces cooler when exposed to the sun.

The criterion for judging the adequacy of field curing provided in the ACI 318 Building Code is that the field-cured test cylinders produce 85% of the strengths developed by companion laboratory-cured cylinders at the age for which strength is specified.

(“Standard Practice for Curing Concrete,” ACI 308; “Standard Specification for Curing Concrete,” ACI 308.1; and “Standard Specifications for Structural Concrete,” ACI 301.)

9.39 JOINTS IN CONCRETE

Several types of joints may occur or be formed in concrete structures:

Construction joints are formed when fresh concrete is placed against hardened concrete.

Expansion joints are provided in long components to relieve compressive stresses that would otherwise result from a temperature rise.

Contraction joints (control joints) are provided to permit concrete to contract during a drop in temperature and to permit drying shrinkage without resulting uncontrolled random cracking.

Contraction joints should be located at places where concrete is likely to crack because of temperature changes or shrinkage. The joints should be inserted where there are thickness changes and offsets. Ordinarily, joints should be spaced 30 ft on center or less in exposed structures, such as retaining walls.

To avoid unsightly cracks due to shrinkage, a dummy-type contraction joint is frequently used (Fig. 9.8). When contraction takes place, a crack occurs at this deliberately made plane of weakness. In this way, the crack is made to occur in a straight line easily sealed.

Control joints may also consist of a 2- or 3-ft gap left in a long wall or slab, with the reinforcement from both ends lapped in the gap. Several weeks after the wall or slab has been concreted, the gap is filled with concrete. By that time, most of the shrinkage has taken place.

In expansion joints, a filler is usually provided to separate the two parts of the structure. This filler should be a compressive substance, such as corkboard or pre-molded mastic. The filler should have properties such that it will not be squeezed out of the joint, will not slump when heated by the sun, and will not stain the surface of the concrete.

To be waterproof, a joint must be sealed. For this purpose, copper flashing may be used. It is usually embedded in the concrete on both sides of the joint, and folded into the joint so that the joint may open without rupturing the metal. The flashing must be strong enough to hold its position when the concrete is cast.

Proprietary flexible water stops and polysulfide caulking compounds may also be used as sealers.

Open expansion joints are sometimes used for interior locations where the opening is not objectionable. When exposed to water from above, as in parking decks, open joints may be provided with a gutter below to drain away water.

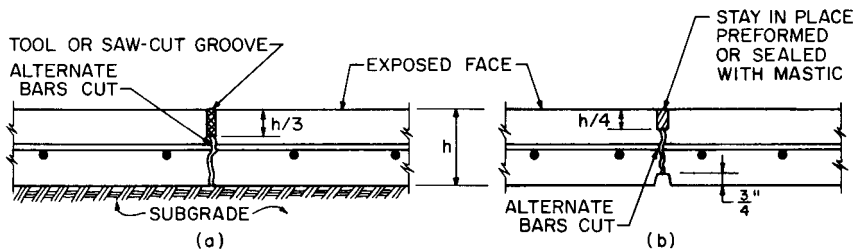

FIGURE 9.8 Control joints for restraining temperature and shrinkage cracks: (a) vertical section through a slab on grade; (b) horizontal section through a wall.

The engineer should show all necessary vertical and horizontal joints on design drawings. All pertinent details affecting reinforcement, water stops, and sealers should also be shown.

Construction joints should be designed and located if possible at sections of minimum shear. These sections will usually be at the center of beams and slabs, where the bending moment is highest. They should be located where it is most convenient to stop work. The construction joint is often keyed for shearing strength.

If it is not possible to concrete an entire floor in one operation, vertical joints preferably should be located in the center of a span. Horizontal joints are usually provided between columns and floor; columns are concreted first, then the entire floor system.

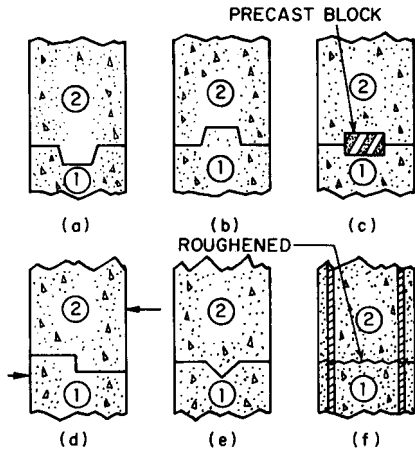

FIGURE 9.9 Types of construction joints. Circled numbers indicate order of casting.

reliance being placed on friction on the roughened surface. This method may be used if the shear forces are small, or if there are large compressive forces or sufficient reinforcement across the joint.

See also Arts. 9.32 to 9.34.

9.40 INSPECTION OF CONCRETE PLACEMENT

Concrete should be inspected for the owner before, during, and after casting. Before concrete is placed, the formwork must be free of ice and debris and properly coated with bond-breaker oil. The rebar must be in place, properly supported to bear any traffic they will receive during concrete placing. Conduit, inserts, and other items to be embedded must be in position, fixed against displacement. Construction personnel should be available, usually carpenters, bar placers and other trades, if piping or electrical conduit is to be embedded, to act as form watchers and to reset any rebar, conduit, or piping displaced.

As concrete is cast, the slump of the concrete must be observed and regulated within prescribed limits, or the specified strengths based on the expected slump may be reduced. An inspector of placing who is also responsible for sampling and

Various types of construction joints are shown in Fig. 9.9. The numbers on each section refer to the sequence of placing concrete.

If the joint is horizontal as in Fig. 9.9a, water may be trapped in the key of the joint. If the joint is vertical, the key is easily formed by nailing a wood strip to the inside of the forms. A raised key, as in Fig. 9.9b, makes formwork difficult for horizontal joints.

In the horizontal joint in Fig. 9.9c, the key is made by setting precast-concrete blocks into the concrete at intermittent intervals. The key in Fig. 9.9d is good if the shear acts in the directions shown.

The V-shaped key in Fig. 9.9e can be made manually in the wet concrete for horizontal joints.

The key is eliminated in Fig. 9.9f,

making cylinders, should test slump, entrained air, temperatures, and unit weights, during concreting and should control any field adjustment of slump and added water and cement. The inspector should also ascertain that handling, placing, and finishing procedures that have been agreed on in advance are properly followed, to avoid segregated concrete. In addition, the inspector should ensure that any emergency construction joints made necessary by stoppage of concrete supply, rain, or other delays are properly located and made in accordance with procedures specified or approved by the engineer.

Inspection is complete only when concrete is cast, finished, protected for curing, and attains full strength.

(“Manual of Concrete Inspection,” ACI SP2.)

STRUCTURAL ANALYSIS OF REINFORCED CONCRETE STRUCTURES

Under the ACI 318 Building Code, reinforced concrete structures generally may be analyzed by elastic theory. When specific limiting conditions are met, certain approximate methods are permitted. For some cases, the Code recommends an empirical method.

9.41 ANALYSES OF ONE-WAY FLOOR AND ROOF SYSTEMS

The ACI 318 Building Code permits an approximate analysis for continuous systems in ordinary building if:

Components are not prestressed.

Beams and one-way slabs are continuous over two or more spans.

In successive spans, the ratio of the larger span to the smaller does not exceed 1.20.

The spans carry only uniform loads.

The ratio of live to dead service load(s) (not factored) does not exceed 3.

Members are prismatic.

This analysis determines the maximum moments and shears at faces of supports and the midspan moments representing envelope values for the respective loading combinations. In this method, factored moments are computed from

$$M_u = Cw_uL_n^2 \quad (9.7)$$

where C = coefficient, given in Fig. 9.10

w_u = uniform factored load

L_n = clear span for positive factored moment or factored shear and the average of adjacent clear spans for negative factored moment

For an elastic (“exact”) analysis, the spans L of members that are not built

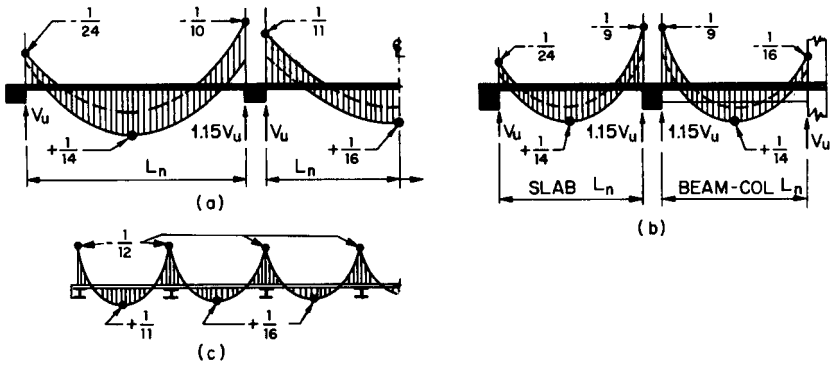

FIGURE 9.10 Coefficients C for calculation of factored bending moments from $M_u = Cw_u L_n^2$ in approximate analysis of beams and one-way slabs with uniform load w_u . For factored shears, $V_u = 0.5w_u L_n$. (a) More than two spans. (b) Two-span beam or slab. (c) Slabs—all spans, $L_u \leq 10$ ft.

integrally with their supports should be taken as the clear span plus the depth of slab or beam but need not exceed the distance between centers of supports. For spans of continuous frames, spans should be taken as the distance between centers of supports. For solid or ribbed slabs with clear spans not exceeding 10 ft, if built integrally with their supports, spans may be taken as the clear distance between supports.

If an elastic analysis is performed for continuous flexural members for each loading combination expected, calculated factored moments may be redistributed if the ratio ρ of tension-reinforcement area to effective concrete area or ratio of $\rho - \rho'$, where ρ' is the compression-reinforcement ratio, to the balanced-reinforcement ratio ρ_b , lie within the limits given in the ACI 318 Building Code. Positive factored moments should be increased by a percentage γ and negative factored moments decreased by γ to reflect the moment redistribution property of underreinforced concrete in flexure. When ρ or $\rho - \rho'$ is not more than $0.5\rho_b$, the percentage is given by

$$\gamma = 20 \left(1 - \frac{\rho - \rho'}{\rho_b} \right) \tag{9.8}$$

For example, suppose a 20-ft interior span of a continuous slab with equal spans is made of concrete with a strength f'_c of 4 ksi and reinforced with bars having a yield strength f_y of 60 ksi. Factored dead and live loads are both 0.100 ksf. The factored moments are determined as follows:

Maximum negative factored moments occur at the supports of the interior span when this span adjacent spans carry both dead and live loads. Call this loading Case 1. For Case 1 then, maximum negative factored moment equals

$$M_u = -(0.100 + 0.100)(20)^2/11 = -7.27 \text{ ft-kips/ft}$$

The corresponding positive factored moment at midspan is 2.73 ft-kips/ft.

Maximum positive factored moment in the interior span occurs when it carries full load but adjacent spans support only dead loads. Call this loading Case 2. For

Case 2, then, the negative factored moment is $-(10.00 - 5.00) = -5.00$ ft-kips/ft, and the maximum positive factored moment is 5.00 ft-kips/ft. Figure 9.11a shows the maximum factored moments.

For the concrete and reinforcement properties given, the balanced-reinforcement ratio computed from Eq. (9.27) is $\rho_b = 0.0285$. Assume now that reinforcement ratios for the top reinforcement and bottom reinforcement are 0.00267 and 0.002, respectively. If alternate bottom bars extend into the supports, $\rho' = 0.001$. Substitution in Eq. (9.8) gives for the redistribution percentage

$$\gamma = 20 \left(1 - \frac{0.00267 - 0.001}{0.0285} \right) = 18.8\%$$

The negative factored moment (Case 1) therefore can be decreased to $M_u = -7.27(1 - 0.188) = -5.90$ ft-kips/ft. The corresponding positive factored moment at midspan is $10 - 5.90 = 4.10$ kips/ft (Fig. 9.11b).

For Case 2 loading, if the negative factored moment is increased 18.8%, it becomes $-5.94 \approx 5.90$ ft-kips/ft. Therefore, the slab should be designed for the factored moments shown in Fig. 9.11b.

9.42 TWO-WAY SLAB FRAMES

For two-way slab systems, the ACI 318 Building Code permits a three-dimensional (space-frame) analysis in which the “equivalent frame” combines the flexibility (reciprocal of stiffness) of the real column and the torsional flexibility of the slabs or beams attached to the column at right angles to the direction of the bending moment under consideration. This method, applicable for all ratios of successive spans and of dead to live load, is an elastic (“exact”) analysis called the “equivalent frame method.”

An approximate procedure, the “direct design method,” is also permitted (within limits of load and span). This method constitutes the direct solution of a one-cycle moment distribution. (See also Art. 9.59.)

(E. S. Hoffman, et al., “Structural Design Guide to the ACI Building Code,” 4th ed., Kluwer Academic Publishers, Boston/Dordrecht/London.)

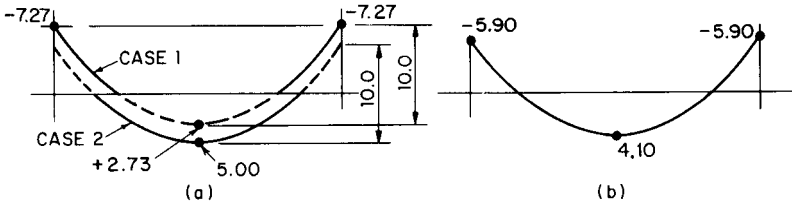

FIGURE 9.11 Factored bending moments in an interior 20-ft span of a continuous one-way slab: (a) factored moments for Case I (this and adjacent spans fully loaded) and Case II (this span fully loaded but adjacent spans with only dead load); (b) Case I factored moments after redistribution.

9.43 SPECIAL ANALYSES

Space limitations preclude more than a brief listing of some of the special analyses required for various special types of reinforced concrete construction and selected basic references for detailed information. Further references to applicable research are available in each of the basic references.

Seismic-loading-resistant ductile frames: ACI 318; ACI Detailing Manual.

High-rise construction, frames, shear walls, frames plus shear walls, and tube concept: "Planning and Design of Tall Buildings," Vols. SC, CL, and CB, American Society of Civil Engineers.

Environmental engineering structures: "Environmental Engineering Concrete Structures," ACI 350R.

Bridges: "Analysis and Design of Reinforced Concrete Bridge Structures," ACI 343R.

Nuclear structures: ASME-ACI Code for Concrete Reactor Vessels and Containments Structures, ACI 359, also ACI 349 and 349R.

It should be noted that the ACI 318 Building Code specifically provides for the acceptance of analyses by computer or model testing to supplement the manual calculations when required by building officials.

STRUCTURAL DESIGN OF FLEXURAL MEMBERS

9.44 STRENGTH DESIGN WITH FACTORED LOADS

Safe, economical strength design of reinforced concrete structures requires that their ultimate-load-carrying capacity be predictable or known. The safe, or service-load-carrying capacity can then be determined by dividing the ultimate-load-carrying capacity by a factor of safety.

The ACI 318 Building Code provides for strength design of reinforced concrete members by use of **factored loads** (actual and specified loads multiplied by load factors). Factored axial forces, shears, and moments in members are determined as if the structure were elastic. Strength-design theory is then used to design critical sections for these axial forces, shears, and moments.

Strength design of reinforced concrete flexural members (Art. 9.46) may be based on the following assumptions and applicable conditions of equilibrium and compatibility of strains:

1. Strains in the reinforcing steel and the concrete is directly proportional to the distance from the neutral axis (Fig. 9.12) except for deep flexural members with a span-depth ratio less than 1.25 of the clear span for simple spans and 2.5 for continuous spans. See also Art. 9.88.

2. The maximum usable strain at the extreme concrete compression surface equals 0.003 in/in

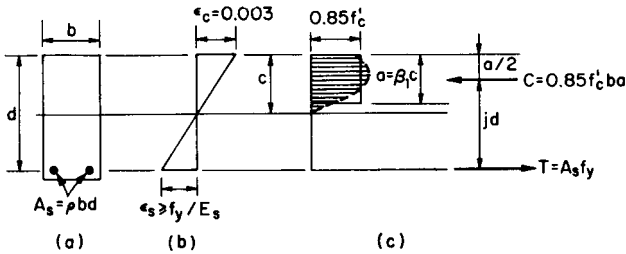

FIGURE 9.12 Stresses and strains in a rectangular reinforced-concrete beam, reinforced for tension only, at ultimate load: (a) cross-section of beam; (b) strain distribution; (c) two types of stress distribution.

3. When the strain, in./in. in reinforcing steel is less than f_y/E_s , where f_y = yield strength of the steel and E_s = its modulus of elasticity (29,000,000 psi), the steel stress, psi, equals 29,000,000 times the steel strain. After the steel yield strength has been reached, the stress remains constant at f_y , though the strain increases.

4. Except for prestressed concrete (Art. 9.104) or plain concrete, the tensile strength of the concrete is negligible in flexure.

5. The shape of the concrete compressive distribution may be assumed to be a rectangle, trapezoid, parabola, or any other shape in substantial agreement with comprehensive strength tests.

6. For a rectangular stress block, the compressive stress in the concrete should be taken as $0.85f'_c$. This stress may be assumed constant from the surface of maximum compressive strain to a depth of $a = \beta_1 c$, where c is the distance to the neutral axis (Fig. 9.12). For $f'_c = 4000$ psi, $\beta_1 = 0.85$. For greater concrete strengths, β_1 should be reduced 0.05 for each 1000 psi in excess of 4000, but β_1 should not be taken less than 0.65.

(See also Art. 9.8.2 for columns).

9.44.1 Strength-Reduction Factors

The ACI Code requires that the strength of a member based on strength design theory include **strength-reduction factors** ϕ to provide for small adverse variations in materials, workmanship, and dimensions individually within acceptable tolerances. The degree of ductility, importance of the member, and the accuracy with which the member's strength can be predicted were considered in considered in assigning values to ϕ :

ϕ should be taken as 0.90 for flexure and axial tension; 0.85 for shear and torsion; 0.70 for bearing on concrete; for axial compression combined with bending, 0.75 for members with spiral reinforcement, and 0.70 for other members; and 0.65 for flexure, compression, shear, and bearing in structural plain concrete.

9.44.2 Load Factors

For combinations of loads, a structure and its members should have the following strength U , computed by adding factored loads and multiplying by a factor based on probability of occurrence of the load combination:

Dead load D and live load L , plus their internal moments and forces:

$$U = 1.4D + 1.7L \quad (9.9)$$

Wind load W :

$$U = 0.75(1.4D + 1.7L + 1.7W) \quad (9.10)$$

When D and L reduce the effects of W :

$$U = 0.9D + 1.3W \quad (9.11)$$

Earthquake forces E :

$$U = 0.75(1.4D + 1.7L + 1.87E) \quad (9.12)$$

When D and L reduce the effects of E :

$$U = 0.9D + 1.43E \quad (9.13)$$

Lateral earth pressure H :

$$U = 1.4D + 1.7L + 1.7H \quad (9.14)$$

When D and L reduce the effects of H :

$$U = 0.9D + 1.7H \quad (9.15)$$

Lateral pressure F from liquids (for well-defined fluid pressures):

$$U = 1.4D + 1.7L + 1.4F \quad (9.16)$$

Impact effects, if any, should be included with the live load L .

Where the structural effects T of differential settlement, creep, shrinkage, or temperature change can be significant, they should be included with the dead load D , and the strength should not be less than $1.4D + 1.4T$, or

$$U = 0.75(1.4D + 1.4T + 1.7L) \quad (9.17)$$

9.45 ALLOWABLE-STRESS DESIGN AT SERVICE LOADS (ALTERNATIVE DESIGN METHOD)

Nonprestressed, reinforced-concrete flexural members (Art. 9.63) may be designed for flexure by the alternative design method of the ACI 318 Building Code (working-stress design). In this method, members are designed to carry service loads (load factors and ϕ are taken as unity) under the straight-line (elastic) theory of

stress and strain. (Because of creep in the concrete, only stresses due to short-time loading can be predicted with reasonable accuracy by this method.)

Working-stress design is based on the following assumptions:

1. A section plane before bending remains plane after bending. Strains therefore vary with distance from the neutral axis (Fig. 9.13c).

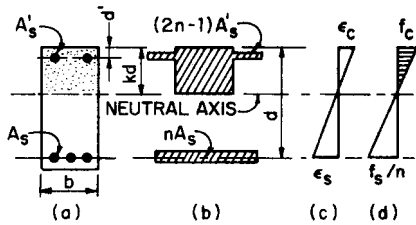

FIGURE 9.13 Stresses and strains in a beam with compression reinforcement, as assumed for working-stress design: (a) rectangular cross-section of beam; (b) transformed section with twice the reinforcing steel area, to allow for effects of creep of concrete; (c) assumed strains; (d) assumed distribution of stresses in the concrete.

2. The stress-strain relation for concrete plots as a straight line under service loads within the allowable working stresses (Fig. 9.13c and d), except for *deep beams*.

3. Reinforcing steel resists all the tension due to flexure (Fig. 9.13a and b).

4. The modular ratio, $n = E_s/E_c$, where E_s and E_c are the moduli of elasticity of reinforcing steel and concrete, respectively, may be taken as the nearest whole number, but not less than 6 (Fig. 9.13b).

5. Except in calculations for deflection, n lightweight concrete should be assumed the same as for normal-weight concrete of the same strength.

6. The compressive stress in the extreme surface of the concrete must not exceed $0.45f'_c$, where f'_c is the 29-day compressive strength of the concrete.

7. The following tensile stress in the reinforcement must not be greater than the following:

Grades 40 and 50	20 ksi
Grade 60 or greater	24 ksi

For $\frac{3}{8}$ -in. or smaller-diameter reinforcement in one-way slabs with spans not exceeding 12 ft, the allowable stress may be increased to 50% of the yield strength but not to more than 30 ksi.

8. For doubly-reinforced flexural members, including slabs with compression reinforcement, an effective modular ratio of $2E_s/E_c$ should be used to transform the compression-reinforcement area for stress computations to an equivalent concrete area (Fig. 9.13b). (This recognizes the effects of creep.) The allowable stress in the compression reinforcement may not exceed the allowable tension stress.

Because the strains in the reinforcing steel and the adjoining concrete are equal, the stress in the tension steel f_s is n times the stress in the concrete f_c . The total force acting on the tension steel then equals $nA_s f_c$. The steel area A_s , therefore can be replaced in stress calculations by a concrete area n times as large.

The transformed section of a reinforced concrete beam is a cross section normal to the neutral surface with the reinforcement replaced by an equivalent area of concrete (Fig. 9.13b). (In doubly-reinforced beams and slabs, an effective modular ratio of $2n$ should be used to transform the compression reinforcement and account for creep and nonlinearity of the stress-strain diagram for concrete.) Stress and strain are assumed to vary with the distance from the neutral axis of the transformed

section; that is, conventional elastic theory for homogeneous beams may be applied to the transformed section. Section properties, such as location of neutral axis, moment of inertia, and section modulus S , may be computed in the usual way for homogeneous beams, and stresses may be calculated from the flexure formula, $f = M/S$, where M is the bending moment at the section. This method is recommended particularly for T-beams and doubly-reinforced beams.

From the assumptions the following formulas can be derived for a rectangular section with tension reinforcement only.

$$\frac{nf_c}{f_s} = \frac{k}{1 - k} \quad (9.18)$$

$$k = \sqrt{2n\rho + (n\rho)^2} - n\rho \quad (9.19)$$

$$j = 1 - \frac{k}{3} \quad (9.20)$$

where $\rho = A_s/bd$ and b is the width and d the effective depth of the section (Fig. 9.13).

Compression capacity:

$$M_c = \frac{1}{2}f_c k j b d^2 = K_c b d^2 \quad (9.21a)$$

where $K_c = \frac{1}{2}f_c k j$.

Tension capacity:

$$M_s = f_s A_s j d = f_s \rho j b d^2 = K_s b d^2 \quad (9.21b)$$

where $K_s = f_s \rho j$.

Design of flexural members for shear, torsion, and bearing, and of other types of members, follows the strength design provisions of the ACI 318 Building Code, because allowable capacity by the alternative design method is an arbitrarily specified percentage of the strength.

9.46 STRENGTH DESIGN FOR FLEXURE

Article 9.44 summarizes the basic assumptions for strength design of flexural members. The following formulas are derived from those assumptions.

The area A_s of tension reinforcement in a reinforced-concrete flexural member can be expressed as the ratio

$$\rho = \frac{A_s}{bd} \quad (9.22)$$

where b = beam width and d = effective beam depth = distance from the extreme compression surface to centroid of tension reinforcement. At nominal (ultimate) strength of a critical section, the stress in this steel will be equal to its yield strength f_y , psi, if the concrete does not first fail in compression. (See also Arts. 9.47 to 9.50 for additional reinforcement requirements.)

9.46.1 Singly-Reinforced Rectangular Beams

For a rectangular beam, reinforced with only tension steel (Fig. 9.12), the total tension force in the steel at nominal (ultimate) strength is

$$T = A_s f_y = \rho f_y b d \quad (9.23)$$

It is opposed by an equal compressive force

$$C = 0.85 f'_c b \beta_1 c \quad (9.24)$$

where f'_c = specified compressive strength of the concrete, psi
 c = distance from extreme compression surface to neutral axis
 β_1 = a constant (given in Art. 9.44)

Equating the compression and tension forces at the critical section gives:

$$c = \frac{\rho f_y}{0.85 \beta_1 f'_c} d \quad (9.25)$$

The criterion for compression failure is that the maximum strain in the concrete equals 0.003 in/in. In that case:

$$c = \frac{0.003}{f_s / E_s + 0.003} d \quad (9.26)$$

where f_s is the steel stress, ksi, and $E_s = 29,000,000$ psi is the steel modulus of elasticity.

Tension-Steel Limitations. Under balanced conditions, the concrete will reach its maximum strain of 0.003 in/in when the tension steel reaches its yield strength f_y . Then, c as given by Eq. (9.26) will equal c as given by Eq. (9.25). Also, the reinforcement ratio for balanced conditions in a rectangular beam with tension steel only becomes:

$$\rho_b = \frac{0.85 \beta_1 f'_c}{f_y} \frac{87,000}{87,000 + f_y} \quad (9.27)$$

All structures should be designed to avoid sudden collapse. Therefore, reinforcement should yield before the concrete crushes. Gradual yielding will occur if the quantity of tensile reinforcement is less than the balanced percentage determined by strength design theory. To avoid compression failures, the ACI 318 Building Code, therefore limits the reinforcement ratio ρ to a maximum of $0.75\rho_b$.

The Code also requires that ρ for positive-moment and negative-moment reinforcement be at least $3\sqrt{f'_c}/f_y$ and not less than $200/f_y$ to prevent sudden collapse when the design moment strength is equal to or less than the cracking moment. This requirement does not apply, however, if the reinforcement area at every section of the member is at least one-third greater than that required by the factored moment. The ratio, $200/f_y$, will govern, except when $f'_c > 4400$ psi. For a statically determinate T-section with the flange in tension, ρ should be at least $6\sqrt{f'_c}/f_y$ with the flange width used for determining ρ .

For flexural members of any cross-sectional shape, without compression reinforcement, the tension reinforcement is limited by the ACI 318 Building Code so

that $A_s f_y$ does not exceed 0.75 times the total compressive force at balanced conditions. The total compressive force may be taken as the area of a rectangular stress block of a rectangular member; the strength of overhanging flanges or compression reinforcement, or both, may be included. For members with compression reinforcement, the portion of tensile reinforcement equalized by compression reinforcement need not be reduced by the 0.75 factor.

Flexural Design Strength: Tension Steel Only. For underreinforced rectangular beams with tension reinforcement only (Fig. 9.12) and a rectangular stress block with depth a ($\rho \leq 0.75\rho_b$), the flexural design strength may be determined from:

$$\phi M_n = 0.90bd^2\rho f_y \left(1 - \frac{0.59\rho f_y}{f'_c} \right) \tag{9.28a}$$

$$= 0.90A_s f_y \left(d - \frac{a}{2} \right) \tag{9.28b}$$

$$= 0.90A_s f_y jd \tag{9.28c}$$

where $a = A_s f_y / 0.85 f'_c b$ and $jd = d - a/2$.

9.46.2 Doubly-Reinforced Rectangular Beams

For a rectangular beam with compression-steel area A'_s and tension-steel area A_s , the compression-reinforcement ratio is

$$\rho' = \frac{A'_s}{bd} \tag{9.29}$$

and the tension-reinforcement ratio is

$$\rho = \frac{A_s}{bd} \tag{9.30}$$

where b = width of beam and d = effective depth of beam. For design, ρ should not exceed

$$0.75 \left(\rho_b - \rho' \frac{f'_s}{f_y} \right) + \rho' \frac{f'_s}{f_y} \tag{9.31a}$$

for

$$\rho_b = \frac{0.85 f'_c \beta_1}{f_y} \frac{87,000}{87,000 + f_y} + \rho' \frac{f'_s}{f_y} \tag{9.31b}$$

where f'_s = stress in the compression steel, psi, and other symbols are the same as those defined for singly-reinforced beams (Art. 9.46.1). The compression force on the concrete alone in a cross-section (Fig. 9.14) is

$$C_{1b} = 0.85 f'_c b a \tag{9.32}$$

where $a = \beta_1 c$ is the depth of the stress block and the compression reinforcement

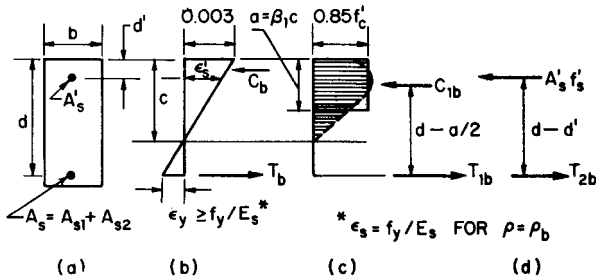

FIGURE 9.14 Stresses and strains, at ultimate load in a rectangular beam with compression reinforcement: (a) beam cross-section; (b) strain distribution; (c) two types of stress distribution; (d) compression stress in reinforcement.

resists $A'_s f'_s$. Forces equal in magnitude to these but opposite in direction stress the tension reinforcement. The depth to the neutral axis c can be found from the maximum compressive strain of 0.003 in/in or by equating the compression and tension forces on the section. (See also Art. 9.64.)

9.46.3 T-Beams

When a T form is used to provide needed compression area for an isolated beam, flange thickness should be at least one-half the web width, and flange width should not exceed 4 times the web width.

When a T is formed by a beam cast integrally with a slab, only a portion of the slab is effective. For a symmetrical T-beam, the effective flange width should not exceed one-fourth the beam span, nor should the width of the overhang exceed 8 times the slab thickness nor one-half the clear distance to the next beam. For a beam having a flange on one side only, the effective flange width should not exceed one-twelfth the span, 6 times the slab thickness, nor one-half the clear distance to the next beam.

The overhang of a T-beam should be designed to act as a cantilever. Spacing of the cantilever reinforcement should not exceed 18 in or 5 times the flange thickness.

In computing the moment capacity of a T-beam, it may be treated as a singly-reinforced beam with overhanging concrete flanges (Fig. 9.15). The compression force on the web (rectangular beam) is

$$C_w = 0.85 f'_c b_w a \tag{9.33}$$

where b_w = width of web. The compression force on the overhangs is

$$C_f = 0.85 f'_c (b - b_w) h_f \tag{9.34}$$

where h_f = flange thickness and b = effective flange width of the T-beam. Forces equal in magnitude to these but opposite in direction stress the tension steel:

$$T_w = A_{sw} f_y \tag{9.35}$$

$$T_f = A_{sf} f_y \tag{9.36}$$

where A_{sw} = area of reinforcing steel required to develop compression strength of

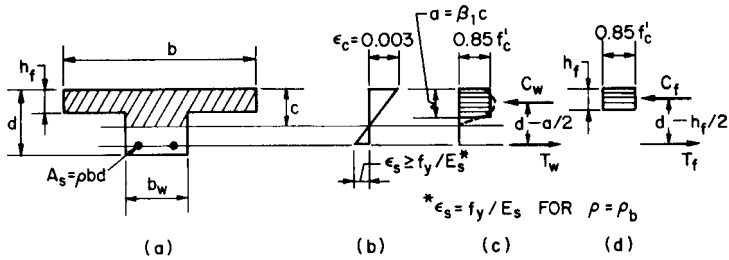

FIGURE 9.15 Stresses and strains in a T-beam at ultimate load: (a) beam cross-section; (b) strain distribution; (c) stress distributions in web; (d) block distribution of flange compression stresses.

web and A_{sf} = area of reinforcing steel required to develop compression strength of overhanging flanges. The reinforcement ratio for balanced conditions is given by

$$\rho_b = \frac{b_w}{b} \left[\frac{0.85 f'_c \beta_1}{f_y} \frac{87,000}{87,000 + f_y} + \frac{A_{sf}}{b_w d} \right] \quad (9.37)$$

The depth to the neutral axis c can be found in the same way as for rectangular beams (Arts. 9.46.1 and 9.46.2).

9.47 SHEAR IN FLEXURAL MEMBERS

Design at a section of a reinforced-concrete flexural member with factored shear force V_u is based on

$$V_u \leq \phi V_n = \phi(V_c + V_s) \quad (9.38)$$

where ϕ = strength-reduction factor (given in Art. 9.44.1)

V_u = factored shear force at a section

V_c = nominal shear strength of concrete

V_s = nominal shear strength provided by reinforcement

Except for brackets, deep beams, and other short cantilevers, the section for maximum shear may be taken at a distance d from the face of the support when the reaction in the direction of the shear introduces compression into the end region of the member.

For shear in two-way slabs, see Art. 9.59.

For nonprestressed flexural members of normal-weight concrete without torsion, the nominal shear strength V_c provided by the concrete is limited to a maximum of $2\sqrt{f'_c} b_w d$, where b_w is the width of the beam web, d = depth to centroid of reinforcement, and f'_c is the specified concrete compressive strength, unless a more detailed analysis is made. In such an analysis, V_c should be obtained from

$$V_c = \left(1.9\sqrt{f'_c} + \frac{2,500\rho_w V_u d}{M_u} \right) b_w d \leq 3.5 \sqrt{f'_c} b_w d \quad (9.39)$$

where M_u = factored bending moment occurring simultaneously with V_u at the section considered, but $V_u d/M_u$ must not exceed 1.0

$$\rho_w = A_s/b_w d$$

A_s = area of nonprestressed tension reinforcement

For one-way joist construction, the ACI 318 Building Code allows these values of V_c to be increased 10%.

For lightweight concrete, V_c should be modified by substituting $f_{ct}/6.7$ for $\sqrt{f'_c}$, where f_{ct} is the average splitting tensile strength of lightweight concrete, but not more than $6.7 \sqrt{f'_c}$. When f_{ct} is not specified, values of $\sqrt{f'_c}$ affecting V_c should be multiplied by 0.85 for sand-lightweight concrete and 0.75 for all-lightweight concrete.

Shear Reinforcement. When V_u exceeds ϕV_c , shear reinforcement must be provided to resist the excess factored shear. The shear reinforcement may consist of stirrups making an angle of 45 to 90° with the longitudinal reinforcement, longitudinal bars bent at an angle of 30° or more, or a combination of stirrups and bent bars. The nominal shear strength provided by the shear reinforcement V_s must not exceed $8 \sqrt{f'_c} b_w d$.

Spacing of required shear reinforcement placed perpendicular to the longitudinal reinforcement should not exceed $0.5d$ for nonprestressed concrete, 75% of the overall depth for prestressed concrete, or 24 in. Inclined stirrups and bent bars should be spaced so that at least one intersects every 45° line extending toward the supports from middepth of the member to the tension reinforcement. When V_s is greater than $4 \sqrt{f'_c} b_w d$, the maximum spacing of shear reinforcement should be reduced by one-half. (See Art. 9.109 for shear-strength design for prestressed concrete members.)

The area required in the legs of a vertical stirrup, in², is

$$A_v = \frac{V_s s}{f_y d} \quad (9.40a)$$

where s = spacing of stirrups, in and f_y = yield strength of stirrup steel, psi. For inclined stirrups, the leg area should be at least

$$A_v = \frac{V_s s}{(\sin \alpha + \cos \alpha) f_y d} \quad (9.40b)$$

where α = angle of inclination with longitudinal axis of member.

For a single bent bar or a single group of parallel bars all bent at an angle α with the longitudinal axis at the same distance from the support, the required area is

$$A_v = \frac{V_s}{f_y \sin \alpha} \quad (9.41)$$

in which V_s should not exceed $3 \sqrt{f'_c} b_w d$.

A minimum area of shear reinforcement is required in all members, except slabs, footings, and joists or where V_u is less than $0.5\phi V_c$. The minimum area of shear reinforcement is given by $A_v = 50b_w s/f_y$.

See also Art. 9.65.

9.48 TORSION IN REINFORCED CONCRETE MEMBERS

Under twisting or torsional moments, a member develops normal (warping) and shear stresses. The ACI 318 Building Code assumes that no torsion is resisted by concrete and the entire nominal torsional strength is provided by reinforcement. The reinforcement required for torsion must be added to that required for shear, moment, and axial force.

Torsional design may be based on

$$T_u < \phi T_s \quad (9.42)$$

where T_u = factored torsional moment

ϕ = strength-reduction factor, = 0.85

T_s = nominal torsional moment strength provided by torsion reinforcement

For non-prestressed members, torsion can be neglected when

$$T_u < \phi \sqrt{f'_c} (A_{cp})^2 / p_{cp} \quad (9.43)$$

where A_{cp} = area enclosed by outside perimeter of concrete cross-section, in.²

p_{cp} = outside perimeter of the concrete cross-section, in.

For prestressed members, torsion effects can be neglected when

$$T_u \leq \phi \sqrt{f'_c} [(A_{cp})^2 / p_{cp}] \sqrt{1 + f_{pc} / 4\sqrt{f'_c}} \quad (9.44)$$

where f_{pc} = compressive stress in concrete (after allowance for all prestress losses) at centroid of cross section resisting externally applied loads or at junction of web and flange when the centroid lies within the flange, psi. (In a composite member, f_{pc} is resultant compressive stress at centroid of composite section, or at junction of web and flange when centroid lies within the flange, due to both prestress and moments resisted by precast members acting alone.)

For T-beam construction, where stirrup reinforcement is required for torsion, it may be more practical to neglect the area and perimeter of the overhanging flanges than to provide reinforcement for them.

In statically indeterminate prestressed and non-prestressed structures, where the torsional moment, T_u , in a member is not required to maintain equilibrium, design may be based upon reduced torsional cracking moments equal to four times the values given in Eqs. (9.43) and (9.44). When taking advantage of redistribution of torsional moments, the end moments of continuous members may be reduced likewise and the positive moments increased.

To reduce unsightly cracking and prevent crushing of surface concrete, the size of a solid cross-section is limited such that

$$\sqrt{(V_u / b_w d)^2 + (T_u p_h / 1.7 A_{oh}^2)^2} \leq \phi (V_c / b_w d + 8\sqrt{f'_c}) \quad (9.45)$$

and the size of a hollow cross section is limited such that

$$(V_u / b_w d) + (T_u p_h / 1.7 A_{oh}^2) \leq \phi (V_c / b_w d + 8\sqrt{f'_c}) \quad (9.46)$$

where A_{oh} = area enclosed by centerline of the outermost closed transverse torsion reinforcement, in²

p_h = perimeter of the centerline of the outermost closed transverse torsion reinforcement, in

The reinforcement for torsion requires that

$$\phi T_n \geq T_u \quad (9.47)$$

where T_n = nominal torsional moment strength which = T_s , the nominal torsional moment strength provided by torsion reinforcement

Stirrups. The transverse reinforcement required for torsion is calculated from

$$T_n = (2A_o A_t f_{yv} \cot \theta) / s \quad (9.48)$$

where s = spacing of torsion reinforcement in direction parallel to longitudinal reinforcement, in

$A_o = 0.85 A_{oh}$

A_t = area of one leg of a closed stirrup within a distance s , in²

f_{yv} = yield strength of closed transverse torsion reinforcement, psi

θ = angle of concrete compression diagonals in truss analogy for torsion, which must not be taken smaller than 30° nor larger than 60° for non-prestressed members but may be taken as 45° for non-prestressed members and as 37.5° for prestressed members with an effective prestress force not less than 40% of the tensile strength of the longitudinal reinforcement

For design, Eq. (9.48) can be re-arranged to calculate

$$A_t / s = T_n / (\phi 2 A_o f_{yv} \cot \theta) \quad (9.48a)$$

where ϕ = strength-reduction factor, = 0.85

Since A_t is defined as the area of one leg of a closed stirrup, it must be taken into account when the stirrup requirements for shear and torsion are added to provide the total amount of transverse reinforcement required. Stirrup area for shear, A_v , is based on all the legs of a stirrup. If the required stirrup area for shear is A_v/s , and that for torsion is A_t/s , the total amount of transverse reinforcement required to resist shear and torsion is calculated

$$\text{Total} \left(\frac{A_{v+t}}{s} \right) = \frac{A_v}{s} + \frac{2A_t}{s} \quad (9.49)$$

Longitudinal Reinforcement. The additional longitudinal reinforcement, A_ℓ , required for torsion is calculated from

$$A_\ell \geq (A_t / s) p_h (f_{yv} / f_{y\ell}) \cot^2 \theta \quad (9.50)$$

where A_t/s = amount calculated from Eq. (9.48a)

$f_{y\ell}$ = yield strength of longitudinal torsion reinforcement

The amount of longitudinal torsion reinforcement in the flexural compression zone may be reduced by an amount equal to $M_u / (0.9 d f_{y\ell})$, where M_u is the factored moment acting at the section in combination with T_u .

Where torsion reinforcement is required, the minimum area of transverse torsion reinforcement, A_t , must also conform to

$$A_t \geq [(50b_w s / f_{yv}) - A_v] / 2 \tag{9.51}$$

and the minimum area of longitudinal torsion reinforcement, A_ℓ , must conform to

$$A_\ell \geq 5 \sqrt{f'_c} A_{cp} / f_{y\ell} - (A_t / s) (f_{yv} / f_{y\ell}) p_h \tag{9.52}$$

where A_t / s must be taken $\geq 25 b_w / f_{yv}$.

The spacing of transverse torsion reinforcement should not exceed the smaller of $p_h / 8$ or 12 in. The longitudinal reinforcement required for torsion must be placed inside closed stirrups with a maximum spacing of 12 in and distributed around their perimeter with one bar or tendon in each corner. Bars must have a diameter $\geq s / 24$ but not less than a #3 size.

Refer to Fig. 9.16 for an example of cross-section properties and reinforcement details of a typical spandrel beam subjected to bending, shear and torsion.

See also Art. 9.66.

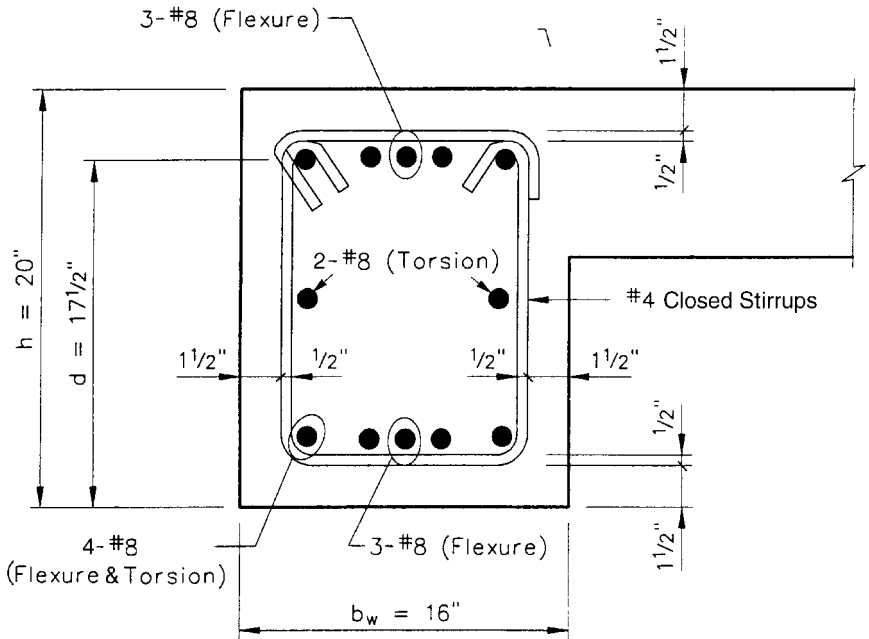

$$A_{cp} = (16)(20) = 320 \text{ in}^2$$

$$P_{cp} = 2(20+16) = 72 \text{ in}$$

$$A_{oh} = (12.5)(16.5) = 206.25 \text{ in}^2$$

$$P_h = 2(12.5+16.5) = 58 \text{ in}$$

FIGURE 9.16 Cross-section properties and reinforcement details of a typical spandrel beam subjected to bending, shear and torsion.

9.49 DEVELOPMENT, ANCHORAGE, AND SPLICES OF REINFORCEMENT

Steel reinforcement must be bonded to the concrete sufficiently so that the steel will yield before it is freed from the concrete. Despite assumptions made in the past to the contrary, bond stress between concrete and reinforcing bars is not uniform over a given length, not directly related to the perimeter of the bars, not equal in tension and compression, and may be affected by lateral confinement. The ACI 318 Building Code requirements therefore reflect the significance of average bond resistance over a length of bar or wire sufficient to develop its strength (**development length**).

The calculated tension or compression force in each reinforcing bar at any section [Eqs. (9.53) to (9.61) and (9.64)] must be developed on each side of that section by a development length L_d , or by end anchorage, or both. Hooks can be used to assist in the development of tension bars only.

The critical sections for development of reinforcement in flexural members are located at the points of maximum stress and where the reinforcement terminates or is bent.

The following requirements of the ACI 318 Building Code for the development of reinforcement were proposed to help provide for *shifts* in the location of maximum moment and for *peak stresses* that exist in regions of tension in the remaining bars wherever adjacent bars are cut off or bent. In addition, these requirements help minimize any loss of shear capacity or ductility resulting from flexural cracks that tend to open early whenever reinforcement is terminated in a tension zone.

9.49.1 Development for All Flexural Reinforcement

Reinforcement should extend a distance of d or $12d_b$, whichever is larger, beyond the point where the steel is no longer required to resist tensile stress, where d is the effective depth of the member and d_b is the nominal diameter of the reinforcement. This requirement, however, does not apply at supports of simple spans and at the free end of cantilevers.

Continuing reinforcement should extend at least the development length L_d beyond the point where terminated or bent reinforcement is no longer required to resist tension.

Reinforcement should not be terminated in a tension zone unless *one* of the following conditions is satisfied:

1. Shear at the cutoff point does not exceed two-thirds of the design shear strength, ϕV_n .
2. Stirrup area A_v not less than $60b_w s / f_y$ and exceeding that required for shear and torsion is provided along each terminated bar over a distance from the termination point equal to $0.75d$. (A_v = cross-sectional area of stirrup leg, b_w = width of member, and f_y = yield strength of stirrup steel, psi.) The spacing should not exceed $d / 8\beta_b$, where β_b is the ratio of the area of the bars cut off to the total area of bars at the cutoff section.
3. For No. 11 bars and smaller, continuing bars provide double the area required for flexure at the cutoff point, and the factored shear does not exceed three-fourths of the design shear strength, ϕV_n .

9.49.2 Development for Positive-Moment Reinforcement

A minimum of one-third the required positive-moment reinforcement for simple beams should extend along the same face of the member into the support, and in beams, for a distance of not less than 6 in.

A minimum of one-fourth the required positive-moment reinforcement for continuous members should extend along the same face of the member into the support, and in beams, for a distance of at least 6 in.

For lateral-load-resisting members, the positive-moment reinforcement to be extended into the support in accordance with the preceding two requirements should be able to develop between the face of the support and the end of the bars the yield strength f_y of the bars.

Positive-moment tension reinforcement at simple supports and at points of inflection should be limited to a diameter such that the development length, in computed for f_y with Eqs. (9.54) to (9.58) and (9.61) does not exceed

$$L_d \leq \frac{M_n}{V_u} + L_a \quad (9.53)$$

where M_n = nominal moment strength at the section, in-lb, assuming all reinforcement at the section stressed to $f_y = A_s f_y (d - a/2)$

V_u = factored shear at the section, lb

L_a = embedment length, in beyond center of support; at a point of inflection, L_a is limited to d or $12d_b$, whichever is greater

d = effective depth, in of member

d_b = nominal bar diameter, in

A_s = area of tensile reinforcement, in²

a = depth, in of rectangular stress block (Art. 9.46.1)

The value of M_n/V_u can be increased by 30% when the ends of the reinforcement are confined by a compressive reaction. It is not necessary to satisfy Eq. (9.53) for reinforcing bars that terminate beyond the center of simple supports with a standard hook, or terminate with a mechanical anchorage equivalent to a standard hook.

9.49.3 Development for Negative-Moment Reinforcement

Negative-moment reinforcement in continuous, restrained, or cantilever members should be developed in or through the supporting member.

Negative-moment reinforcement should have sufficient distance between the face of the support and the end of each bar to develop its full yield strength.

A minimum of one-third of the required negative-moment reinforcement at the face of the support should extend beyond the point of inflection the greatest of d , $12d_b$, or one-sixteenth of the clear span.

9.49.4 Computation of Development Length

Tension development length, L_d , is the length of deformed bar or deformed wire required to develop, or to transfer to the concrete, the full tensile capacity of the bar or wire. The tension development length of an uncoated bar or wire in normal weight concrete is expressed as a function of yield strength of the bar; f_y ; the square

root of the compressive strength of the concrete, $\sqrt{f'_c}$; the diameter of the bar, d_b ; depth of concrete below horizontal bars; bar spacings; concrete cover; and lateral confinement reinforcement such as stirrups or ties. The ACI 318 Building Code reinforcements also contain provisions to account for epoxy-coated bars and embedment of bars in lightweight aggregate concrete. Tension development length can also be reduced when more flexural reinforcement is provided than the amount required by analysis.

The ACI 318-99 Building Code provides the designer with a choice of methods for determining tension development length, L_d —a **direct short-cut method**; or a **more rigorous method** which is applicable to all conditions of bar spacing, concrete cover and transverse reinforcement. A third method is provided by the commentary to ACI 318-99, which sanctions use of the provisions in the 1989 Code.

Using the **direct short-cut method** for determining the tension development length of deformed bars or deformed wire in tension—with a clear spacing not less than d_b , concrete cover not less than d_b , and stirrups and ties throughout L_d not less than code minimum; or clear spacing not less than $2d_b$ and concrete cover not less than d_b —the equations for calculating L_d are:

for #6 and smaller bars and wire

$$L_d = (0.04f_y \alpha\beta\lambda/\sqrt{f'_c})d_b \geq 12 \text{ in.} \quad (9.54)$$

for #7 and larger bars and wire

$$L_d = (0.05f_y \alpha\beta\lambda/\sqrt{f'_c})d_b \geq 12 \text{ in.} \quad (9.55)$$

The direct **short-cut method's** equations for determining the tension development deformed bars and deformed wire for all other cases are:

for #6 and smaller bars and wire

$$L_d = (0.06f_y \alpha\beta\lambda/\sqrt{f'_c})d_b \geq 12 \text{ in.} \quad (9.56)$$

for #7 and larger bars and wire

$$L_d = (0.075f_y \alpha\beta\lambda/\sqrt{f'_c})d_b \geq 12 \text{ in.} \quad (9.57)$$

In Eqs. (9.54) through (9.57):

$\alpha = 1.3$ for top bars and 1.0 for other bars; “top bars” are horizontal bars with more than 12 in. of concrete cast below them

$\beta = 1.0$ for uncoated bars

$\beta = 1.5$ for epoxy-coated bars with cover $< 3d_b$; or clear spacing $< 6d_b$

$\beta = 1.2$ for other concrete cover and clear spacing conditions of epoxy-coated bars

The product of $\alpha\beta$ need not be taken more than 1.7

$\lambda =$ factor for lightweight aggregate concrete = 1.3

$\lambda = 6.7 \sqrt{f'_c}/f_{ct} \geq 1.0$ when the splitting tensile strength, f_{ct} , of lightweight aggregate concrete is specified.

Under the **more rigorous method**, tension development length is calculated:

$$L_d = \frac{0.075f_y \alpha\beta\gamma\lambda d_b}{\sqrt{f'_c}[(c + K_{tr})/d_b]} \quad (9.58)$$

where $\gamma = 0.8$ for bar sizes #3–#6
 $\gamma = 1.0$ for bar sizes #7–#18

The term $(c + K_{tr})/d_b$ is limited to a value of 2.5

c = the smaller of: (1) one-half of the center-to-center spacing of the bars; or (2) the concrete cover to the center of the bar, in

$K_{tr} = A_{tr}f_{yt}/(1500 \text{ sn})$

A_{tr} = total area of all transverse reinforcement within the spacing s , which crosses the potential plane of splitting through the bars being developed in²

f_{yt} = specified yield strength of transverse reinforcement, psi

s = maximum center-to-center spacing of transverse reinforcement within L_d , in

n = number of bars being developed along the plane of splitting.

Increased L_d is required for bundled bars: in 3-bar bundles, 20%; in 4-bar bundles, 33%. For determining the appropriate modifying factors for use with bundled bars, a unit of bundled bars should be treated as a single bar with a diameter derived from the equivalent total area.

Application of all the various interdependent tension development length requirements to each structural element in design would be extremely difficult and a waste of design time. The authors recommend that the designer check the actual dimensions available for tension development in the connection (or from a cutoff point established as a fraction of the span on typical design drawing details), compare to a table of development lengths required for each bar size, and select the bar size allowable. Table 9.8, which is based on the direct short-cut method, presents values of tension L_d for each size bar for normal-weight concrete with compressive strengths of 3000, 4000 and 5000 psi. Note that separate values are tabulated for “top bars” and “other bars.”

9.49.5 Anchorage with Hooks

For rebars in tension, standard 90° and 180° end hooks can be used as part of the length required for development or anchorage of the bars. Table 9.9 gives the minimum tension embedment length L_{dh} required with standard end hooks (Fig. 9.17 and Table 9.9) and Grade 60 bars to develop the specified yield strength of the bars.

9.49.6 Development for Welded-Wire Fabric in Tension

For deformed welded-wire fabric (WWF) with at least one cross wire within the development length not less than 2 in. from the point of critical section (Fig. 9.18), the tension development length is the length calculated from Eqs. (9.54) and (9.56) using the **direct short-cut method** or from Eq. (9.58) using the **more rigorous method** and then multiplied by a wire fabric factor. The wire fabric factor is the larger of

$$(f_y - 35,000)/f_y \leq 1.0 \quad (9.59)$$

or

$$5 d_b/s_w \leq 1.0 \quad (9.60)$$

TABLE 9.8 Tension Development Lengths, L_d , for Grade 60 Uncoated Bars (Inches)

Bar size no.	$f'_c = 3,000$ psi				$f'_c = 4,000$ psi				$f'_c = 5,000$ psi			
	Top bars		Other bars		Top bars		Other bars		Top bars		Other bars	
	Case 1	Case 2	Case 1	Case 2	Case 1	Case 2	Case 1	Case 2	Case 1	Case 2	Case 1	Case 2
3	22	32	17	25	19	28	15	22	17	25	13	19
4	29	43	22	33	25	37	19	29	22	33	17	26
5	36	54	28	41	31	47	24	36	28	42	22	32
6	43	64	33	50	37	56	29	43	33	50	26	38
7	63	94	48	72	54	81	42	63	49	73	37	56
8	72	107	55	82	62*	93	48	71	55	83	43	64
9	81	121	62	93	70	105	54	81	63	94	48	72
10	91	136	70	105	79	118	61	91	70	105	54	81
11	101	151	78	116	87	131	67	101	78	117	60	90
14	121	181	93	139	105	157	81	121	94	140	72	108
18	161	241	124	186	139	209	107	161	125	187	96	144

NOTES:

- Values are based on Section 12.2.2 in ACI 318-99 Building Code.
- Case 1 and Case 2 are defined:

Case	Structural element	
	Beams and columns	Other elements
1	Concrete cover $\geq d_b$, c.-c. bar spacing $\geq 2 d_b$ and with stirrups or ties throughout L_d not less than Code minimum	Concrete over $\geq d_b$, c.-c. bar spacing $\geq 3 d_b$
2	Concrete cover $< d_b$ or c.-c. bar spacing $< 2 d_b$	Concrete cover $< d_b$ or c.-c. bar spacing $< 3 d_b$

- Values are for normal-weight concrete.

4. Standard 90° or 180° end hooks may be used to replace part of the required development length. See Table 9.9.

* Sample Calculation: For Case 1, bar size no. 8; using Eq. (9.55), $L_d = (0.05 f_y \alpha \beta \lambda / \sqrt{f'_c}) d_b$ where $f_y = 60,000$ psi; $\alpha = 1.3$ for "top" bars; $\beta = 1.0$ for uncoated bars; $\lambda = 1.0$ for normal-weight concrete; $f'_c = 4,000$ psi; and $d_b = 1.0$ in. Thus, $L_d = (0.05 \times 60,000 \times 1.3 \times 1.0 \times 1.0 / \sqrt{4,000})(1.0) = 61.7$ or 62 in.

TABLE 9.9 Minimum Embedment Lengths for Hooks on Steel Reinforcement in Tension

a. Embedment lengths L_{dh} , in for standard end hooks on Grade 60 bars in normal-weight concrete*

Bar size no.	Concrete compressive strength f'_c , psi					
	3000	4000	5000	6000	7000	8000
3	6	6	6	6	6	6
4	8	7	6†	6†	6†	6†
5	10	9	8	7	7	6†
6	12	10	9	8	8	7†
7	14	12	11	10	9	9
8	16	14	12	11	10	10
9	18	15	14	13	12	11
10	20	17	15	14	13	12†
11	22	29	17	16	14	14†
14	37	32	29	27	25	23
18	50	43	39	35	33	31

b. Embedment lengths, in to provide 2-in. concrete cover over tail of standard 180° end hooks

No. 3	No. 4	No. 5	No. 6	No. 7	No. 8	No. 9	No. 10	No. 11	No. 14	No. 18
6	7	7	8	9	10	12	14	15	20	25

*Embedment length for 90° and 180° standard hooks is illustrated in Fig. 9.17. Details of standard hooks are given in Table 9.7. Side cover required is a minimum of 2½ in. End cover required for 90° hooks is a minimum of 2 in. To obtain embedment lengths for grades of steel different from Grade 60, multiply L_{dh} given in Table 9.9 by $f_y/60,000$. If reinforcement exceeds that required, multiply L_{dh} by the ratio of area required to that provided.

†For 180° hooks at right angles to exposed surfaces, obtain L_{dh} from Table 9.9b to provide 2-in. minimum cover to tail (Fig. 9.17a).

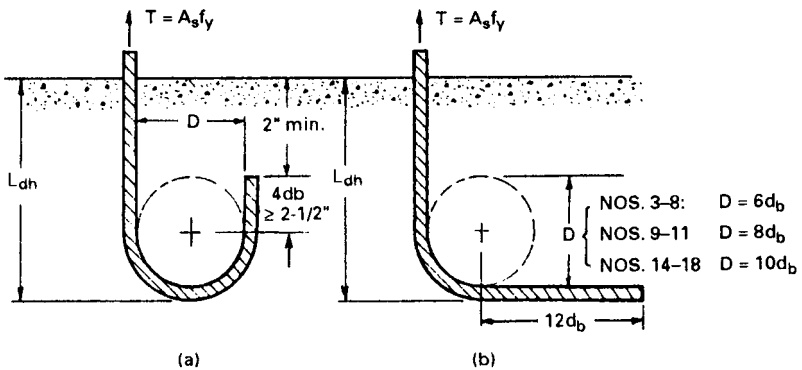

FIGURE 9.17 Embedment lengths for 90° and 180° standard hooks.

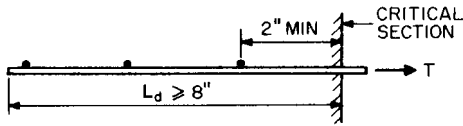

FIGURE 9.18 Minimum development length for deformed welded-wire fabric.

where d_b = nominal diameter of the wire, in
 s_w = spacing of the wires being developed, in

The resulting development length should be at least 8 in except for determining lap splice lengths. When using Eqs. (9.54), (9.56) or (9.58), an epoxy-coated welded wire fabric factor of 1.0 can be taken for β . For deformed WWF with no cross wires within the development length or with a single cross wire less than 2 in from the point of the critical section, the wire fabric factor should also be taken as 1.0.

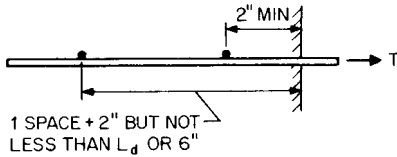

FIGURE 9.19 Minimum development length for plain welded-wire fabric.

Plain welded-wire fabric is considered to be developed by embedment of two cross wires. The closer cross wire should be located not less than 2 in from the point of critical section (Fig. 9.19). The ACI 318 Building Code also requires the development length L_d , measured from the point of critical section to the outermost cross wire, to be at least

$$L_d = \frac{0.27A_w f_y \lambda}{s_w \sqrt{f'_c}} \geq 6 \text{ in.} \quad (9.61)$$

where λ is the factor for lightweight-aggregate concrete, as indicated in Art. 9.49.4. If excess tension reinforcement is provided, L_d may be reduced by the ratio of area of steel required to the area of steel provided. The development length should be at least 6 in. except in calculation of lap splices.

9.49.7 Tension Lap Splices

Bar sizes No. 11 or less and deformed wire may be spliced by lapping. Tension lap splices are classified in two classes, A and B, depending on the stress in the bars to be spliced. The minimum lap length L_s is expressed as a multiple of the tension development length L_d of the bar or deformed wire (Art. 9.49.4).

Class A tension lap splices include splices at sections where the tensile stress due to factored loads does not exceed $0.5f_y$ and not more than one-half the bars at these sections are spliced within one Class A splice length of the section. For Class A splices,

$$L_s = L_d \geq 12 \text{ in.} \quad (9.62)$$

Class B tension lap splices include splices at sections where the tensile stress

exceeds $0.5f_y$ and where more than 50% of the bars at the section are spliced. For Class B splices,

$$L_s = 1.3L_d \geq 12 \text{ in} \quad (9.63)$$

Laps for tension splices for uncoated Grade 60 rebars in normal-weight concrete with $f'_c = 3000, 4000$ and 5000 psi are given in Table 9.10.

The tension lap-splice lengths for welded-wire fabric are indicated in Figs. 9.20 and 9.21.

9.49.8 Development for Compression Reinforcement

Basic development length L_{db} , in., for deformed bars in compression may be computed from

$$L_{db} = \frac{0.02d_b f_y}{\sqrt{f'_c}} \geq 0.0003d_b f_y \geq 8 \text{ in} \quad (9.64)$$

Compression development length L_d is calculated by multiplying L_{db} by optional modification factors. When bars are enclosed by a spiral at least $\frac{1}{4}$ in in diameter and with not more than a 4-in pitch, or by ties at least size No. 4 with a spacing not more than 4 in., a modification factor of 0.75 may be used but the lap should be at least 8 in. If excess reinforcement is provided, L_{db} may be reduced by the ratio of the area of steel required to area of steel provided. For general practice, with concrete compressive strength $f'_c \geq 3000$ psi, use $22d_b$ for compression embedment of dowels (Table 9.11).

For bundled bars in compression, the development length of each bar within the bundle should be increased by 20% for a three-bar bundle and 33% for a four-bar bundle.

9.49.9 Compression Lap Splices

Minimum lap-splice lengths of rebars in compression L_s vary with nominal bar diameter d_b and yield strength f_y of the bars. For bar sizes No. 11 or less, the compression lap-splice length is the largest of 12 in or the values computed from Eqs. (9.65a) and (9.65b):

$$L_s = 0.0005f_y d_b \quad f_y \leq 60,000 \text{ psi} \quad (9.65a)$$

$$L_s = (0.0009f_y - 24)d_b \quad f_y > 60,000 \text{ psi} \quad (9.65b)$$

When f'_c is less than 3000 psi, the length of lap should be one-third greater than the values computed from the preceding equations.

When the bars are enclosed by a spiral, the lap length may be reduced by 25%. For general practice, use 30 bar diameters for compression lap splices (Table 9.11). Spiral should conform to requirements of the ACI 318 Building Code: Spirals should extend from top of footing or slab in any story to the level of the lowest horizontal reinforcement in members supported above. The ratio of volume of spiral reinforcement to the total volume of the concrete core (out-to-out of spirals) should be at least that given in Art. 9.83. Minimum spiral diameter in cast-in-place con-

TABLE 9.10 Tension Lap Splice Lengths for Grade 60 Uncoated Bars (Inches)

Bar size no.	Lap class	$f'_c = 3,000$ psi				$f'_c = 4,000$ psi				$f'_c = 5,000$ psi			
		Top bars		Other bars		Top bars		Other bars		Top bars		Other bars	
		Case 1	Case 2	Case 1	Case 2	Case 1	Case 2	Case 1	Case 2	Case 1	Case 2	Case 1	Case 2
3	A	22	32	17	25	19	28	15	22	17	25	13	19
	B	28	42	22	32	24	36	19	28	22	33	17	25
4	A	29	43	22	33	25	37	19	29	22	33	17	26
	B	37	56	29	43	32	48	25	37	29	32	22	33
5	A	36	54	28	41	31	47	24	36	28	42	22	32
	B	47	70	36	54	40	60	31	47	36	54	28	42
6	A	43	64	33	50	37	56	29	43	33	50	26	38
	B	56	84	43	64	48	72	37	56	43	65	33	50
7	A	63	94	48	72	54	81	42	63	49	73	37	56
	B	81	122	63	94	70	106	54	81	63	94	49	73
8	A	72	107	55	82	62	93	48	71	55	83	43	64
	B	93	139	72	107	80*	121	62	93	72	108	55	83
9	A	81	121	62	93	70	105	54	81	63	94	48	72
	B	105	157	81	121	91	136	70	105	81	122	63	94
10	A	91	136	70	105	79	118	61	91	70	105	54	81
	B	118	177	91	136	102	153	79	118	91	137	70	105
11	A	101	151	78	116	87	131	67	101	78	117	60	90
	B	131	196	101	151	113	170	87	131	101	152	78	117

NOTES:

1. Values are based on Sections 12.2.2 and 12.15 in ACI 318-99 Building Code.
2. See notes under Table 9.8 for definitions of Case 1 and Case 2.
3. Values are for normal-weight concrete.

* Sample Calculation:

From Sample Calculation under Table 9.8; for Case 1, bar size no. 8, top bars, $L_d = 61.7$ in.

For Class B tension lap splice,

$$\begin{aligned} \text{Lap length} &= 1.3 L_d \\ &= 1.3 (61.7) \\ &= 80.2 \text{ or } 80 \text{ in.} \end{aligned}$$

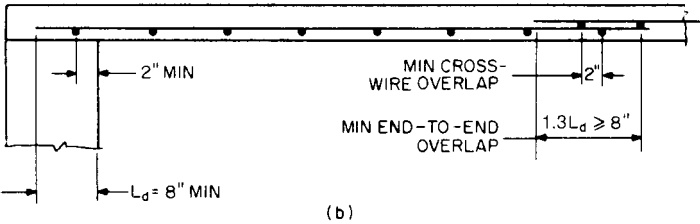
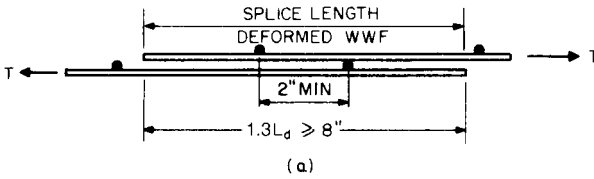

FIGURE 9.20 (a) Minimum lap splice length for deformed welded-wire fabric. (b) Slab reinforced with deformed welded-wire fabric.

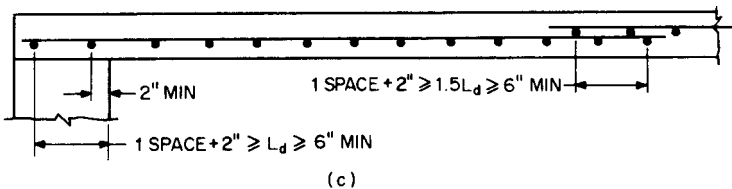
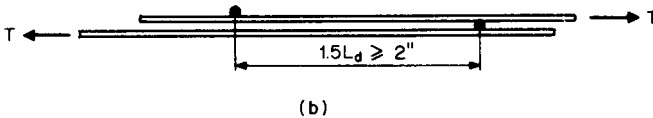
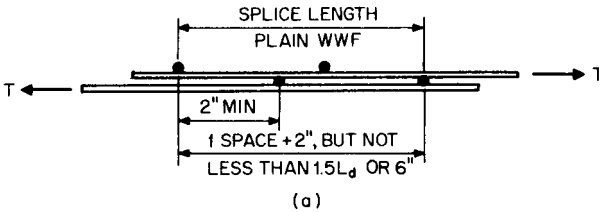

FIGURE 9.21 Minimum lap splice length for plain welded-wire fabric. Use the larger of the values shown in (a) and (b). In calculation of splice length, the computed value of development length L_d , not the minimum required value, should be used. (a) Splice length when steel area used is less than twice the required area. (b) Splice length when steel area used is two or more times the required area. (c) Slab reinforced with plain welded-wire fabric providing twice the required reinforcement area.

TABLE 9.11 Compression Dowel Embedment and Compression Lap Splices, in for Grade 60 Bars and All Concrete with $f'_c \geq 3000$ psi

Bar size no.	Recommended dowel embedment $22d_b$	Minimum lap length	
		Standard lap $30d_b$	With column spirals* $22.5d_b$
3	9	12	12
4	11	15	12
5	14	19	14
6	17	23	17
7	20	27	20
8	22	30	23
9	25	34	25
10	28	38	29
11	31	43	32
14	37	...**	...**
18	50	...**	...**

*For use in spirally-reinforced columns with spirals conforming to requirements in Art. 9.49.9.

**Not permitted.

struction is $\frac{3}{8}$ in. Clear spacing between spirals should be limited to 1 to 3 in. Spirals should be anchored by $1\frac{1}{2}$ extra turns of spiral bar or wire at each end of a spiral unit. Lap splices, or full mechanical or welded splices can be used to splice spiral reinforcement. Lap splice lengths should comply with Table 9.12, but not be less than 12 in.

The ACI 318 Building Code contains provisions for lap splicing bars of different sizes in compression. Length of lap should be the larger of the compression development length required for the larger size bar or the compression lap-splice

TABLE 9.12 Lap Splice Lengths of Spiral Reinforcement

Spiral reinforcement	Lap splice length
Deformed uncoated bar or wire	$48d_b$
Plain uncoated bar or wire	$72d_b$
Epoxy-coated deformed bar or wire	$72d_b$
Plain uncoated bar or wire with a standard stirrup or tie hook at ends of lapped spiral reinforcement*	$48d_b$
Epoxy-coated deformed bar or wire with a standard stirrup or tie hook at ends of lapped spiral reinforcement*	$48d_b$

* The hooks must be embedded within the core confined by the spiral reinforcement.

length required for the smaller bar. It is permissible to lap-splice the large bar sizes, Nos. 14 and 18, to No. 11 and smaller bars.

9.49.10 Mechanical and Welded Splices

As an alternative to lap splicing, mechanical splices or welded splices may be used. When traditional lap splices satisfy all requirements, they are generally the most economical. There are conditions, however, where they are not suitable: The ACI 318 Building Code does not permit lap splices of the large-size bars (Nos. 14 and 18) except in compression to No. 11 and smaller bars. Lap splices cause congestion at the splice locations and their use then may be impracticable. Under certain conditions, the required length of tension lap splices for No. 11 and similar-size bars can be excessive and make the splices uneconomical. For these reasons, mechanical splices or welded splices may be suitable alternatives.

Mechanical splices are made with proprietary devices. The ACI 318 Building Code requires a full mechanical splice to have a capacity, in tension or compression, equal to at least 125% of the specified f_y of the bar. End-bearing mechanical splices may be used where the bar stress due to all conditions of factored loads is compressive. For these types of compression-only splices, the ACI 318 Building Code prescribes requirements for the squareness of the bars ends. Descriptions of the commercially-available proprietary mechanical splice devices are given in "Mechanical Connections of Reinforcing Bars," ACI 439.3R, and "Reinforcement Anchorages, and Splices," Concrete Reinforcing Steel Institute.

For a full-welded splice, the ACI 318 Building Code requires the butt-welded bars to have a tensile capacity of at least 125% of the specified f_y of the bar. Welding should conform to "Structural Welding Code—Reinforcing Steel" (ANSI/AWS D1.4), American Welding Society.

9.49.11 Anchorage of Web Reinforcement

Stirrups are reinforcement used to resist shear and torsion. They are generally bars, wire or welded-wire fabric, either single leg or bent into L, U, or rectangular shapes.

Stirrups should be designed and detailed to be installed as close as possible to the compression and tension surfaces of a flexural member as concrete cover requirements and the proximity of other reinforcing steel will permit. They should be installed perpendicular or inclined with respect to flexural reinforcement and spaced closely enough to cross the line of every potential crack. Ends of single-leg, simple U stirrups, or transverse multiple U stirrups should be anchored by one of the following means:

1. A standard stirrup hook around a longitudinal bar for stirrups fabricated from No. 5 bars or D31 wire or smaller sizes. Stirrups fabricated from bar sizes Nos. 6, 7, and 8 in Grade 40 can be anchored similarly.

2. For stirrups fabricated from bar sizes Nos. 6, 7, and 8 in Grade 60, a standard stirrup hook around a longitudinal bar plus a minimum embedment of $0.014d_b f_y / \sqrt{f'_c}$ between midheight of the member and the outside end of the hook.

Each leg of simple U stirrups made of plain welded-wire fabric should be anchored by one of the following means:

1. Two longitudinal wires located at the top of the U and spaced at 2 in.
2. One longitudinal wire located at a distance of $d/4$ or less from the compression face and a second wire closer to the compression face and spaced at least 2 in from the first wire. (d = distance, in from compression surface to centroid of tension reinforcement.) The second wire can be located on the stirrup leg beyond a bend, or on a bend with an inside diameter of at least $8d_b$.

Each end of a single-leg stirrup, fabricated from plain or deformed welded-wire fabric, should be anchored by two longitudinal wires spaced at 2 in minimum. The inner wire of the two longitudinal wires should be located at least the larger of $d/4$ or 2 in from the middepth of the member $d/2$. The outer longitudinal wire at the tension face of the member should be located not farther from the face than the portion of primary flexural reinforcement closest to the face.

Between anchored ends, each bend in the continuous portion of a simple U or multiple U stirrup should enclose a longitudinal bar.

9.49.12 Stirrup Splices

Pairs of U stirrups or ties placed to form a closed unit may be considered properly spliced when the legs are lapped over a minimum distance of $1.3L_d$. In members at least 18 in deep, such splices may be considered adequate for No. 3 bars of Grade 60 and Nos. 3 and 4 bars of Grade 40 if the legs extend the full available depth of the member.

9.50 CRACK CONTROL

Because of the effectiveness of reinforcement in limiting crack widths, the ACI 318 Building Code requires minimum areas of steel and limits reinforcement spacing, to control cracking.

Beams and One-Way Slabs. If, in a structural floor or roof slab, principal reinforcement extends in one direction only, shrinkage and temperature reinforcement should be provided normal to the principal reinforcement, to prevent excessive cracking. The additional reinforcement should provide at least the ratios of reinforcement area to gross concrete area of slab given in Table 9.13, but not less than 0.0014.

To control flexural cracking, tension reinforcement in beams and one-way slabs should be well distributed in zones of maximum concrete tension when the design

TABLE 9.13 Minimum Shrinkage and Temperature Reinforcement

In slabs where Grade 40 or 50 deformed bars are used	0.0020
In slabs where Grade 60 deformed bars or welded-wire fabric, deformed or plain, are used (Table 9.18)	0.0018
In slabs reinforced with steel having a yield strength f_y exceeding 60,000 psi measured at a strain of 0.0035 in/in	$108/f_y$
This reinforcement should not be placed farther apart than 5 times the slab thickness or more than 18 in.	

yield strength of the steel f_y is greater than 40,000 psi. Spacing of principal reinforcement in slabs should not exceed 18 in or 3 times the slab thickness, except in concrete-joist construction.

Where slab flanges of beams are in tension, a part of the main reinforcement of the beam should be distributed over the effective flange width or a width equal to one-tenth the span, whichever is smaller. When the effective flange width exceeds one-tenth the span, some longitudinal reinforcement should be provided in the outer portions of the flange. Also, reinforcement for one-way joist construction should be uniformly distributed throughout the flange.

To control concrete cracking in beams and one-way slabs, the spacing, s , of flexural reinforcement adjacent to a concrete surface in tension should not be greater than

$$s \leq 540/f_s - 2.5 c_c \quad (9.66)$$

where the calculated service load stress, f_s , can be taken as 60% of specified yield strength and c_c is the clear concrete cover. This change in ACI 318-99 replaces the z factor of ACI 318-95 and previous code editions and directly specifies the maximum bar spacing for crack control without reference to interior or exterior exposure.

For beams with Grade 60 reinforcement and tension bars with 2 in clear concrete cover, the maximum bar spacing $s = 540/36 - 2.5(2) = 15 - 5 = 10$ in.

Two-Way Slabs. Flexural cracking in two-way slabs is significantly different from that in one-way slabs. For control of flexural cracking in two-way slabs, such as solid flat plates and flat slabs with drop panels, the ACI 318 Building Code restricts the maximum spacing of tension bars to twice the overall thickness h of the slab but not more than 18 in. In waffle slabs or over cellular spaces, however, reinforcement should be the same as that for shrinkage and temperature in one-way slabs (see Table 9.13).

9.51 DEFLECTION OF REINFORCED-CONCRETE BEAMS AND SLABS

Reinforced-concrete flexural members must have adequate stiffness to limit deflection to an amount that will not adversely affect the serviceability of the structure under service loads.

Beam and One-Way Slabs. Unless computations show that deflections will be small (Table 9.14), the ACI 318 Building Code requires that the depth h of non-prestressed, one-way solids slabs, one-way ribbed slabs, and beams of normal-weight concrete—with Grade 60 reinforcement—be at least the fraction of the span L given in Table 9.15.

When it is necessary to compute deflections, calculation of short-term deflection may be based on elastic theory, but with an effective moment of inertia I_e .

For normal-weight concrete,

$$I_e = \left(\frac{M_{cr}}{M_a} \right)^3 I_g + \left[1 - \left(\frac{M_{cr}}{M_a} \right)^3 \right] I_{cr} \leq I_g \quad (9.67)$$

TABLE 9.14 Maximum Ratios of Computed Deflection to Span L for Beams and Slabs

Type of member	Deflection to be considered	Deflection limitation
Flat roofs not supporting or attached to nonstructural elements likely to be damaged by large deflections	Immediate deflection due to the live load	$L/180^*$
Floors not supporting or attached to nonstructural elements likely to be damaged by large deflections	Immediate deflection due to the live load	$L/360$
Roof or floor construction supporting or attached to nonstructural elements likely to be damaged by large deflections	That part of the total deflection that occurs after attachment of the nonstructural elements (the sum of the long-term deflection due to all sustained loads and the immediate deflection due to any additional live load) [†]	$L/480^‡$
Roof or floor construction supporting or attached to nonstructural elements not likely to be damaged by large deflections		$L/240^§$

* This limit is not intended to safeguard against ponding. Ponding should be checked by suitable calculations of deflection, including the added deflections due to ponded water, and considering long-term effects of all sustained loads, camber, construction, tolerances and reliability of provisions for drainage.

[†] The long-term deflection may be reduced by the amount of deflection that occurs before attachment of the nonstructural elements.

[‡] This limit may be exceeded if adequate measures are taken to prevent damage to supported or attached elements.

[§] But not greater than the tolerance provided for the nonstructural elements. This limit may be exceeded if camber is provided so that the total deflection minus the camber does not exceed the limitation.

TABLE 9.15 Minimum Depths h of Reinforced-Concrete Beams and One-Way Slabs*

	One-way solid slabs	Beams and one-way ribbed slabs
Cantilever	$L/10 = 0.1000L$	$L/8 = 0.1250L$
Simple span	$L/20 = 0.0500L$	$L/16 = 0.0625L$
Continuous:		
End span	$L/24 = 0.0417L$	$L/18.5 = 0.0540L$
Interior span	$L/28 = 0.0357L$	$L/21 = 0.0476L$

* For members with span L (Art. 9.41) not supporting or attached to partitions or other construction likely to be damaged by large deflections. Thinner members may be used if justified by deflection computations. For structural lightweight concrete of unit weight w , lb/ft³, multiply tabulated values by $1.65 - 0.005w \geq 1.09$, for $90 < w < 120$. For reinforcement with yield strength $f_y > 60,000$ psi, multiply tabulated values by $0.4 + f_y/100,000$.

- where M_{cr} = cracking moment = $f_r I_g / y_t$
- M_a = service-load moments for which deflections are being compared
- I_g = gross moment of inertia of concrete section
- I_{cr} = moment of inertia of cracked section transformed to concrete (for solid slabs, see Fig. 9.22)
- f_r = modulus of rupture of concrete, psi = $7.5 \sqrt{f'_c}$
- f'_c = specified concrete compressive strength, psi
- y_t = distance from centroidal axis of gross section, neglecting the reinforcement, to the extreme surface in tension.

When structural lightweight concrete is used, f_r in the computation of M_{cr} should be taken as $1.12f_{ct} \leq 7.5 \sqrt{f'_c}$, where f_{ct} = average splitting tensile strength, psi, of the concrete. When f_{ct} is not specified, f_r should be taken as $5.6 \sqrt{f'_c}$ for all lightweight concrete and as $6.4 \sqrt{f'_c}$ for sand-lightweight concrete.

For deflection calculations for continuous spans, I_e may be taken as the average of the values obtained from Eq. (9.67) for the critical positive and negative moments.

Additional long-term deflection for both normal-weight and lightweight concrete flexural members can be estimated by multiplying the immediate deflection due to the sustained load by $\zeta / (1 + 50\rho')$, where ζ = time-dependent factor (2.0 for 5

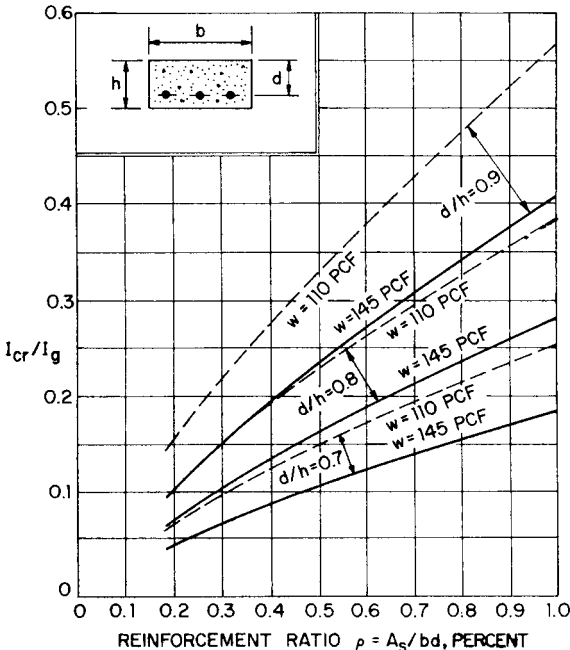

FIGURE 9.22 Chart for determination of moment of inertia I_{cr} of transformed (cracked) section of one-way solid slab, given the moment of inertia of the gross section, $I_g = bh^3/12$, reinforcement ratio $\rho = A_s/bd$, unit weight w of concrete, pcf, and ratio d/h of effective depth to thickness, for $f'_c = 4$ ksi.

years or more, 1.4 for 12 months, 1.2 for 6 months, and 1.0 for 3 months, and ρ' = compression-steel ratio, the area of the compression reinforcement A'_s , in.², divided by the concrete area bd , in.².

The sum of the short-term and long-term deflections should not exceed the limits given in Table 9.14.

Two-Way Slabs. Unless computations show that deflections will not exceed the limits listed in Table 9.14, the ACI 318 Building Code prescribes a minimum thickness for non-prestressed two-way slabs. For two-way slabs without interior beams, with a ratio of long to short span not exceeding 2, and with Grade 60 reinforcement, the Code requires that the thickness h be at least the fraction of the clear span given in Table 9.16. The thickness based on Table 9.16 cannot be less than 5 in. for slabs without drop panels nor less than 4 in. for slabs with drop panels.

For two-way slabs having beams on all four edges, with $\alpha_m \leq 0.2$, the minimum thickness h should be based on the preceding criteria for two-way slabs without interior beams. For $0.2 < \alpha_m \leq 2.0$, the minimum thickness should not be less than

$$h = \frac{L_n(0.8 + f_y/200,000)}{36 + 5\beta(\alpha_m - 2)} \tag{9.68}$$

and not less than 5 in.

For $\alpha_n > 2.0$, the thickness should not be less than

$$h = \frac{L_n(0.8 + f_y/200,000)}{36 + 9\beta} \tag{9.69}$$

and not less than 3.5 in.

where L_n = clear span in long direction, in.

α_m = average value of α for all beams along panel edges

α = ratio of flexural stiffness of beam section to flexural stiffness of a width of slab bounded laterally by the centerline of the adjacent panel, if any, on each side of the beam

β = ratio of clear span in long direction to clear span in short direction

The computed deflections of prestressed-concrete construction should not exceed the values listed in Table 9.14.

TABLE 9.16 Minimum Thickness h of Two-Way Slabs without Interior Beams (Grade 60 Reinforcement)

Without drop panels			With drop panels		
Exterior panels		Interior panels	Exterior panels		Interior panels
Without edge beams	With edge beams*		Without edge beams	With edge beams*	
$\frac{L_n}{30}$	$\frac{L_n}{33}$	$\frac{L_n}{33}$	$\frac{L_n}{33}$	$\frac{L_n}{36}$	$\frac{L_n}{36}$

* Beams between columns along exterior edges; $\alpha \geq 0.8$ for the edge beam.

ONE-WAY REINFORCED-CONCRETE SLABS

A one-way reinforced-concrete slab is a flexural member that spans in one direction between supports and is reinforced for flexure only in one direction (Art. 9.52). If a slab is supported by beams or walls on four sides, but the span in the long direction is more than twice that in the short direction, most of the load will be carried in the short direction; hence, the slab can be designed as a one-way slab.

One-way slabs may be solid, ribbed, or hollow. (For one-way ribbed slabs, see Arts. 9.54 to 9.58.) Hollow one-way slabs are usually precast (Art. 9.100). Cast-in-place, hollow one-way slabs can be constructed with fiber or cardboard-cylinder forms, inflatable forms that can be reused, or precast hollow boxes or blocks. One-way slabs can be haunched at the supports for flexure or for shear strength.

9.52 ANALYSIS AND DESIGN OF ONE-WAY SLABS

Structural strength, fire resistance, crack control, and deflections of one-way slabs must be satisfactory under service loads.

Strength and Deflections. Approximate methods of frame analysis can be used with uniform loads and spans that conform to ACI 318 Building Code requirements (see Art. 9.41). Deflections can be computed as indicated in Art. 9.51, or in lieu of calculations the minimum slab thicknesses listed in Table 9.15 may be used. In Fig. 9.22 is a plot of ratios of moments of inertia of cracked to gross concrete section for one-way slabs. These curves can be used to simplify deflection calculations.

Strength depends on slab thickness and reinforcement and properties of materials used. Slab thickness required for strength can be computed by treating a 1-ft width of slab as a beam (Arts. 9.45 and 9.46).

Fire Resistance. One-way reinforced concrete slabs, if not protected by a fire-resistant ceiling, must have a thickness that conforms to the fire-resistant rating required by the statutory building code. Table 9.17 gives minimum slab thickness for various fire-resistance ratings for normal-weight and structural-lightweight-concrete construction. Providing a minimum $\frac{3}{4}$ -in. concrete cover for reinforcement in restrained construction is adequate under the *Uniform Building Code* and *Standard Building Code* for fire-resistance ratings up to 4 hours.

Reinforcement. Requirements for minimum reinforcement for crack control are summarized in Art. 9.50. Table 9.18 lists minimum reinforcement when Grade 60 bars are used. Reinforcement required for flexural strength can be computed by treating a 1-ft width of slab as a beam (Arts. 9.44 to 9.46).

Rebar weights, lb/ft² of slab area, can be estimated From Fig. 9.24a for one-way, continuous, interior spans of floor or roof slabs made of normal-weight concrete.

One-way reinforced concrete slabs with spans less than 10 ft long can be reinforced with a single layer of draped welded-wire fabric for both positive and negative factored moments. These factored moments can be taken equal to $w_u L^2/12$, where w_u is the total factored uniform load and L is the span, defined in Art. 9.41,

TABLE 9.17 Minimum Slab Thickness, in, for Various Fire-Resistive Ratings

Type of concrete	Fire-resistive rating		
	1 hour	2 hours	3 hours
<i>Normal weight concrete</i>			
Top slab thickness*			
Siliceous aggregate	3.5	5.0	6.2
Carbonate aggregate	3.2	4.6	5.7
<i>Structural lightweight concrete</i>			
Top slab thickness*			
Sand-lightweight	2.7	3.8	4.6
Lightweight	2.5	3.6	4.4

* From Table 7-7-C-C in *Uniform Building Code* Std. 7-7 or Table 709.2.2.1 in *Standard Building Code*.

TABLE 9.18 Minimum and Maximum Reinforcement for One-Way Concrete Slabs

Slab thickness h , in	Minimum reinforcement*			Maximum reinforcement†		
	Area A_s , in ² /ft	Bar size and spacing, in	Weight‡, psf	Area A_s , in ² /ft	Bar size and spacing, in	Weight‡, psf
4	0.086	No. 3 @ 12▲	0.38	0.552	No. 6 @ 9½	1.90
4½	0.097	No. 3 @ 13½	0.33	0.648	No. 6 @ 8	2.25
5	0.108	No. 3 @ 12	0.38	0.744	No. 6 @ 7	2.58
5½	0.119	No. 3 @ 11	0.41	0.840	No. 6 @ 6	3.00
6	0.130	No. 4 @ 18	0.45	0.924	No. 7 @ 7½	3.27
6½	0.140	No. 4 @ 17	0.49	1.020	No. 7 @ 7	3.50
7	0.151	No. 4 @ 15½	0.52	1.104	No. 8 @ 8½	3.77
7½	0.162	No. 4 @ 14½	0.55	1.200	No. 8 @ 7½	4.27
8	0.173	No. 4 @ 13½	0.59	1.284	No. 9 @ 9	4.53
8½	0.184	No. 4 @ 13	0.62	1.380	No. 9 @ 8½	4.80
9	0.194	No. 4 @ 12	0.67	1.476	No. 9 @ 8	5.10

* For Grade 60 reinforcement. Minimum area $A_s \geq 0.0018bh$, where b = slab width and h = slab thickness.

† For $f'_c = 3000$ psi; no compression reinforcement; $0.75 \rho_b = 0.016$; and ¾ in concrete cover (not exposed to weather). Maximum area $A_s = 0.016bd$, where d = effective depth of slab.

‡ Weight is based on the bar size and spacing for a 1-ft wide by 1-ft length of slab. No transverse reinforcement is included in the weight.

▲ This spacing for a 4-in slab is the maximum spacing for flexure but can be increased to 18 in for temperature and shrinkage reinforcement.

if the slab meets ACI 318 Building Code requirements for approximate frame analysis with uniform loads.

For development (bond) of reinforcement, see Art. 9.49.

Shear. Shear strength is usually not critical in one-way slabs carrying uniform loads, but the ACI 318 Building Code requires that it be investigated (see Art. 9.47).

9.53 EMBEDDED PIPES IN ONE-WAY SLABS

Generally, embedded pipes or conduit, other than those merely passing through, should not be larger in outside dimension than one-third the slab thickness and should be spaced at least three diameters or widths on centers. Piping in solid one-way slabs is required to be placed between the top and bottom reinforcement unless it is for radiant heating or snow melting.

ONE-WAY CONCRETE-JOIST CONSTRUCTION

One-way concrete-joist construction consists of a monolithic combination of cast-in-place, uniformly spaced ribs (joists) and top slab (Fig. 9.23). (See also Art. 9.52). The ribs are formed by placing rows of permanent or removable fillers in what would otherwise be a solid slab.

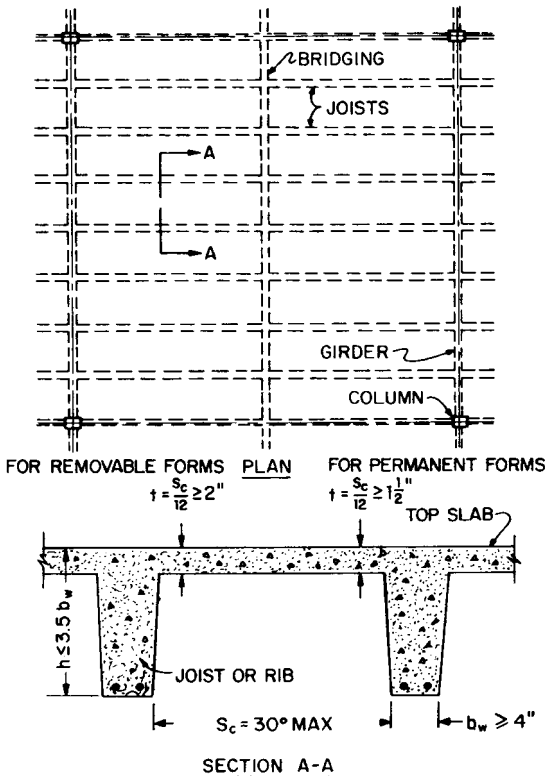

FIGURE 9.23 Typical one-way reinforced-concrete joist construction.

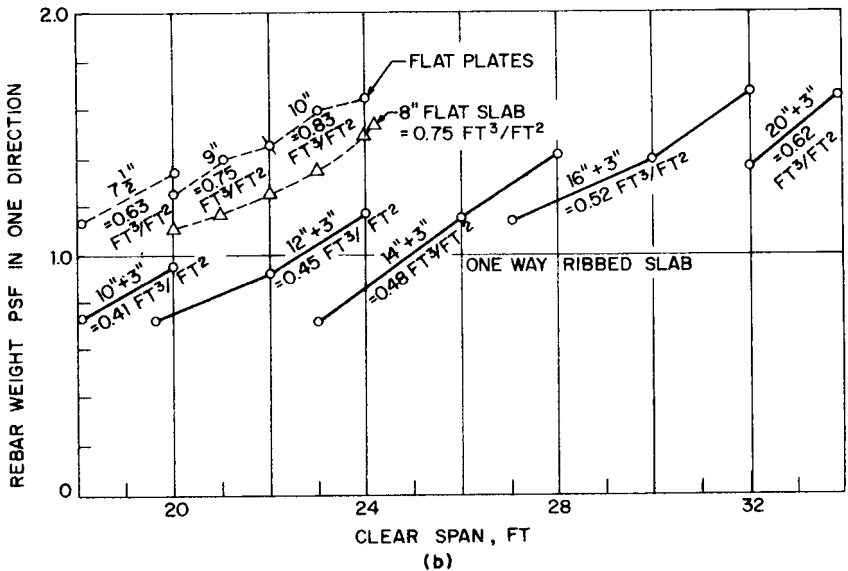
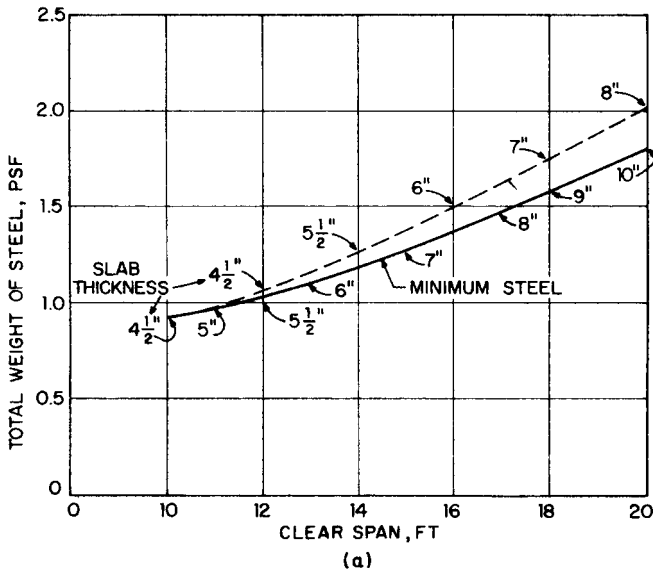

FIGURE 9.24 For use in preliminary estimates, weights of reinforcing steel for an interior span of a continuous slab: (a) for a one-way solid slab of 3000-psi concrete carrying 100-psf service live load (170-psf factored live load); (b) for flat-plate, flat-slab, and one-way joist construction. See also Fig. 9.31.

One-way joist construction was developed to reduce dead load. For long spans, the utility of solid-slab construction is offset by the increase in dead load of the slab. One-way concrete-joist construction provides adequate depth with less dead load than for solid slabs, and results in smaller concrete and reinforcement quantities per square foot of floor area.

Uniform-depth floor and roof construction can be obtained by casting the joists integral with wide, supporting band beams of the same total depth as the joists. This design eliminates the need for interior beam forms.

9.54 STANDARD SIZES OF JOISTS

One-way concrete-joist construction that exceeds the dimensional limitations of the ACI 318 Building Code must be designed as slabs and beams. These dimensional limitations are:

Maximum clear spacing between ribs—30 in

Maximum rib depth—3.5 times rib width

Minimum rib width—4 in

Minimum top-slab thickness with removable forms—2 in but not less than one-twelfth the clear spacing of ribs

Minimum top-slab thickness with permanent forms—1½ in but not less than one-twelfth the clear spacing of ribs

Removable form fillers can be standard steel *pans* or hardboard, corrugated cardboard, fiberboard, or glass-reinforced plastic. Standard removable steel pans that conform to “Types and Sizes of Forms for One-Way Concrete-Joist Construction,” (ANSI/CRSI A48.1-1986), American National Standards Institute, include 20- and 30-in widths and depths of 8, 10, 12, 14, 16, and 20 in. Standard steel square-end pans are available in 36-in lengths. Widths of 10, 15, and 20 in and tapered end fillers are available as special items. For forms 20 and 30 in wide, tapered end forms slope to 16 and 25 in, respectively, in a distance of 3 ft.

9.55 DESIGN OF ONE-WAY CONCRETE-JOIST CONSTRUCTION

One-way concrete joists must have adequate structural strength, and crack control and deflection must be satisfactory under service loads. Approximate methods of frame analysis can be used with uniform loads and spans that conform to requirements of the ACI 318 Building Code (see Art. 9.41). Table 9.15 lists minimum depths of joists to limit deflection, unless deflection computations justify shallower construction (Table 9.14). Load tables in the Concrete Reinforcing Steel Institute’s “CRSI Design Handbook” indicate when deflections under service live loads exceed specified limits.

Economy can be obtained by designing joists and slabs so that the same-size forms can be used throughout a project. It will usually be advantageous to use square-end forms for interior spans and tapered ends for end spans, when required with a uniform depth.

TABLE 9.19 Temperature and Shrinkage Reinforcement for One-Way Joist Construction

Top-slab thickness, in	Required area of temperature and shrinkage reinforcement, in ²	Reinforcement	Reinforcement weight, psf
2	0.043	WWF 4 × 12, W1.5/W1	0.19
2½	0.054	WWF 4 × 12, W2/W1	0.24
3	0.065	WWF 4 × 12, W2.5/W1	0.29
3½	0.076	No. 3 bars @ 17½ in	0.26
4	0.086	No. 3 bars @ 15 in	0.30
4½	0.097	No. 3 bars @ 13½ in	0.33
5	0.108	No. 3 bars @ 12 in	0.38
5½	0.119	No. 3 bars @ 11 in	0.41

Fire Resistance. Table 9.17 gives minimum top-slab thickness for fire resistance when a fire-resistant ceiling is not used.

Temperature and Shrinkage Reinforcement. This reinforcement must be provided perpendicular to the ribs and spaced not farther apart than 5 times the slab thickness, or 18 in. The required area of Grade 60 reinforcement for temperature and shrinkage is 0.0018 times the concrete area (Table 9.19). For flexural reinforcement, see Art. 9.56. For shear reinforcement, see Art. 9.57.

Embedded Pipes. Top slabs containing horizontal conduit or pipes that are allowed by the ACI 318 Building Code (Art. 9.53) must have a thickness of at least 1 in plus the depth of the conduit or pipe.

Bridging. Distribution ribs are constructed normal to the main ribs to distribute concentrated loads to more than one joist and to equalize deflections. These ribs are usually made 4 to 5 in wide and reinforced top and bottom with one No. 4 or one No. 5 continuous rebar. One distribution rib is usually used at the center of spans of up to 30 ft, and two distribution ribs are usually placed at the third points of spans longer than 30 ft.

Openings. These can be provided in the top slab of one-way concrete joist construction between ribs without significant loss in flexural strength. Header joists must be provided along openings that interrupt one or more joists.

9.56 REINFORCEMENT OF JOISTS FOR FLEXURE

Reinforcement required for strength can be determined as indicated in Art. 9.46, by treating as a beam a section symmetrical about a rib and as wide as the spacing of ribs on centers.

Minimum Reinforcement. For f'_c not greater than 4400 psi, reinforcement (both positive and negative) with a yield strength f_y should have an area equal to or greater than $200/f_y$ times the concrete area of the rib $b_w d$, where b_w is the rib width and d = rib depth. For f'_c exceeding 4400 psi, the area of reinforcement should be at least equal to $3\sqrt{f'_c} b_w d / f_y$. Less reinforcement can be used, however, if the areas of both the positive and negative reinforcement at every section are one-third greater than the amount required by analysis. (See also Art. 9.55.)

Maximum Reinforcement. Positive- and negative-moment reinforcement ratios must not be greater than three-quarters of the ratio that produces balanced conditions (Art. 9.46). The positive-moment reinforcement ratio is based on the width of the top flange, and the negative-moment reinforcement ratio is based on the width of the rib b_w .

Reinforcement for one-way concrete-joist construction consists of straight top and bottom bars, cut off as required for moment.

For top-slab reinforcement, straight top- and bottom-bar arrangements provide more flexibility in attaining uniform distribution of top bars to control cracking in the slab than straight and bent bars.

Requirements for structural integrity included in the ACI 318 Building Code affect detailing of the bottom bars in the ribs. Over supports, at least one bottom bar should be continuous or lap spliced to a bottom bar in the adjacent span with a Class A tension lap splice (Art. 9.49.7). At exterior supports, one bottom bar should be terminated with a standard hook.

For development (bond) of reinforcement, see Art. 9.49.

Figure 9.24*b* shows rebar quantities, lb/ft² of floor or roof area, for continuous interior spans of one-way concrete-joist construction made with normal-weight concrete for superimposed factored live load of 170 psf, for preliminary estimates.

9.57 SHEAR IN JOISTS

The factored shear force V_u at a section without shear reinforcement should not exceed

$$V_u = \phi V_c = \phi(2.2\sqrt{f'_c} b_w d) \quad (9.70)$$

where V_c = nominal shear strength of the concrete

ϕ = strength-reduction factor (Art. 9.44) = 0.85

d = distance, in from extreme compression surface to centroid of tension steel

b_w = rib width, in.

Based on satisfactory performance of joist construction, the ACI 318 Building Code allows the nominal shear strength V_c for concrete in joists to be taken 10% greater than for beams or slabs. The width b_w can be taken as the average of the width of joist at the compression face and the width at the tension reinforcement. The slope of the vertical taper of ribs formed with removable steel pans can safely be assumed as 1 in 12. For permanent concrete block fillers, the shell of the block can be included as part of b_w , if the compressive strength of the masonry is equal to or greater than that of the concrete.

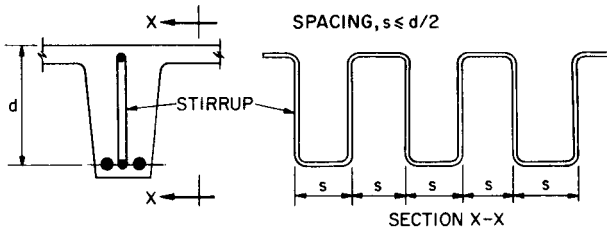

FIGURE 9.25 Stirrups for concrete joist construction.

If shear controls the design of one-way concrete-joist construction, tapered ends can be used to increase the shear capacity. The Concrete Reinforcing Steel Institute’s “CRSI Design Handbook” has comprehensive load tables for one-way concrete-joist construction that indicate where shear controls and when tapered ends are required for simple, end, and interior spans.

For joists supporting uniform loads, the critical section for shear strength at tapered ends is the narrow end of the tapered section. Shear need not be checked within the taper.

Reinforcement for shear must be provided when the factored shear force V_u exceeds the shear strength of the concrete ϕV_c . The use of single-prong No. 3 stirrups spaced at half depth, such as that shown in Fig. 9.25, is practical in narrow joists; they can be placed between two bottom bars.

9.58 WIDE-MODULE JOIST CONSTRUCTION

Wide-module joist construction, which is also referred to as “skip-joist” construction, is an approach to reduce form costs and develop longer spans than standard one-way joist systems (Art. 9.54). Where statutory building codes require thickness of top slabs at or about 4.5 in for fire ratings, the flexural capacity of the slab is under-utilized within limitations of standard joist dimensions with maximum clear spacing between joists of 30 in. The wide-module joist concept utilizes standard reusable joist forms with alternate ribs blocked off. See Fig. 9.26. Deeper-size forms with ribs depths 16 in or 20 in below the slab are usually used in wide-module construction. Rib spacings may be 6 ft or more depending upon depth of rib, or module established by architectural reasons.

The alternate name “skip-joist” is accurate only in that a potential rib is indeed omitted or “skipped” The ribs are designed as beams. Minimum concrete cover on

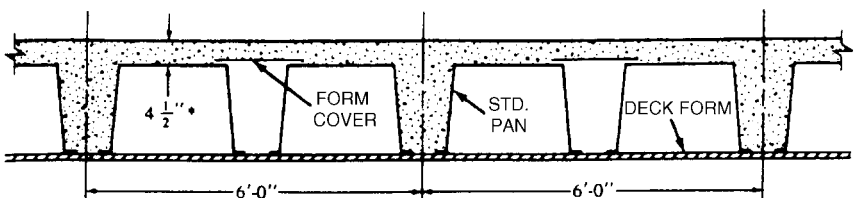

FIGURE 9.26 General arrangement of standard reusable forms for wide-module joist systems.

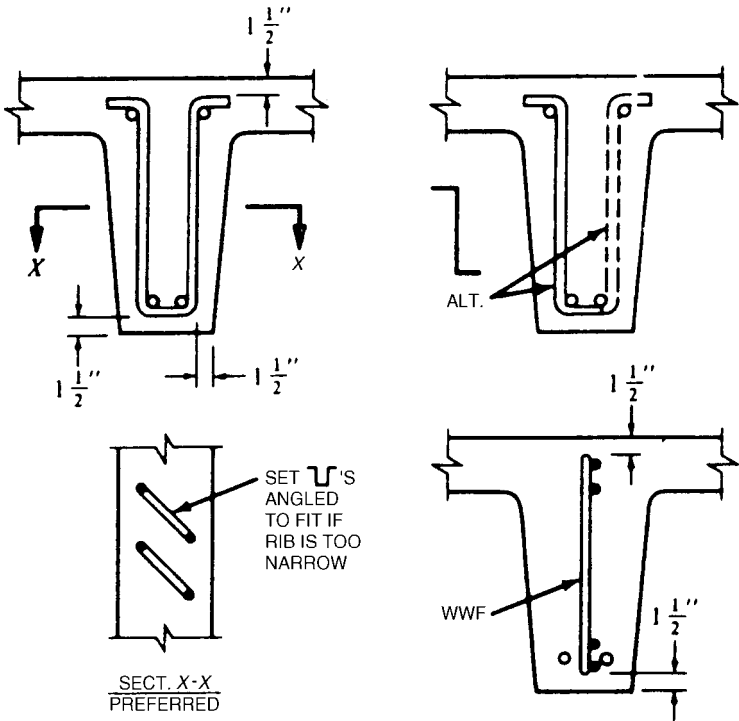

FIGURE 9.27 Various arrangements of shear reinforcement.

reinforcement is 1.5 in., instead of 0.75 in. as in standard joists. Minimum shear reinforcement is required. Shear carried by the concrete is 10% less than that allowed for standard joists. Draped two-way reinforcement in the top slab is permitted.

The principal practical problem is providing shear reinforcement in the amounts required in the ribs—detailed for practicable placing in narrow sections. Vertical U-stirrups are acceptable, although practicable bending limitations may require that they be set at an angle to the longitudinal reinforcement. See Fig. 9.27. Single leg stirrups with alternating direction of the hooked ends have been considered. The ACI 318 Building Code also permits single leg, deformed or plain welded wire fabric (WWF) meeting special requirements. Figure 9.27 shows several possible details. Minimum shear reinforcement requirements will control in most cases, either throughout the span or at a short distance from supports.

TWO-WAY SLAB CONSTRUCTION

A two-way slab is a concrete panel reinforced for flexure in more than one direction. (See also Art. 9.63.) Many variations of this type of construction have been used for floors and roofs, including flat plates, solid flat slabs, and waffle flat slabs. Generally, the columns that support such construction are arranged so that their

centerlines divide the slab into square or nearly square panels, but if desired, rectangular, triangular, or even irregular panels may be used.

9.59 ANALYSIS AND DESIGN OF FLAT PLATES

The flat plate is the simplest form of two-way slab—simplest for analysis, design, detailing, bar fabrication and placing, and formwork. A flat plate is defined as a two-way slab of uniform thickness supported by any combination of columns and walls, with or without edge beams, and without drop panels, column capitals, and brackets.

Shear and deflection limit economical flat-plate spans to under about 30 ft for light loading and about 20 to 25 ft for heavy loading. While use of reinforcing-steel or structural-steel shear heads for resisting shear at columns will extend these limits somewhat, their main application is to permit use of smaller columns. A number of other variations, however, can be used to extend economical load and span limits (Arts. 9.60 and 9.61).

The ACI 318 Building Code permits two methods of analysis for two-way construction: *direct design*, within limitations of span and load, and *equivalent frame* (Art. 9.42). Limitations on use of direct design are:

A minimum of three spans continuous in each direction

Rectangular panels with a ratio of longer to shorter span, center-to-center of supports within a panel, not greater than 2

Successive span ratios, center-to-center of supports in each direction, not to exceed 2:3

Columns offset from centerlines of successive columns not more than 0.10 span in either direction

Specified ratio of live load to dead load (unfactored) does not exceed 2

All loads are due to gravity only and uniformly distributed over the entire panel

9.59.1 Design Procedures for Flat Plates

The procedure for either method of design begins with selection of preliminary dimensions for review, and continues with six basic steps.

Step 1. Select a plate thickness expected to be suitable for the given conditions of load and span. This thickness, unless deflection computations justify thinner plates, should not be less than h determined from Table 9.16. With Grade 60 reinforcement, minimum thickness is, from Table 9.16, for an interior panel

$$h = \frac{L_n}{33} \geq 5 \text{ in} \quad (9.71)$$

where L_n = clear span in the direction moments are being determined. Also, as indicated in Table 9.16, for discontinuous panels, the minimum $h = L_n/30 \geq 5$ in if no edge beam is present.

Step 2. Determine for each panel the total static factored moment

$$M_o = 0.125w_uL_2L_n^2 \tag{9.72}$$

where L_2 = panel width (center-to-center spans transverse to direction in which moment is being determined)

w_u = total factored load, psf = $1.4D + 1.7L$, typically

D = dead load, psf

L = live load, psf

Step 3. Apportion M_o to positive and negative bending moments. In the direct-design method:

For interior spans, the negative factored bending moment is

$$M_u = -0.65M_o \tag{9.73}$$

and the positive factored bending moment is

$$M_u = 0.35M_o \tag{9.74}$$

For end spans (edge panels), M_o is distributed as indicated in Table 9.20.

Step 4. Distribute panel moments M_u to column and middle strips.

Column strip is a design strip with a width of $0.25L_2 \leq 0.25L_1$ on each side of the column centerline, where L_1 is the center-to-center span in the direction in which moments are being determined (Fig. 9.28).

Middle strip is the design strip between two column strips (Fig. 9.28).

For flat plates without beams, the distribution of M_u becomes:

For positive moment, column strip 60%, middle strip 40%

For negative moment at the edge column, column strip 100%

For interior negative moments, column strip 75%, middle strip 25%

A factored moment may be modified up to 10% so long as the sum of the positive and negative moments in the panel in the direction being considered is at least that given by Eq. (9.72).

TABLE 9.20 Distribution of M_o for the End Span of a Flat Slab

	Without edge beam	With edge beam
Negative factored moment at edge column	0.26	0.30
Positive factored moment	0.52	0.50
Negative factored moment at first interior column	0.70	0.70

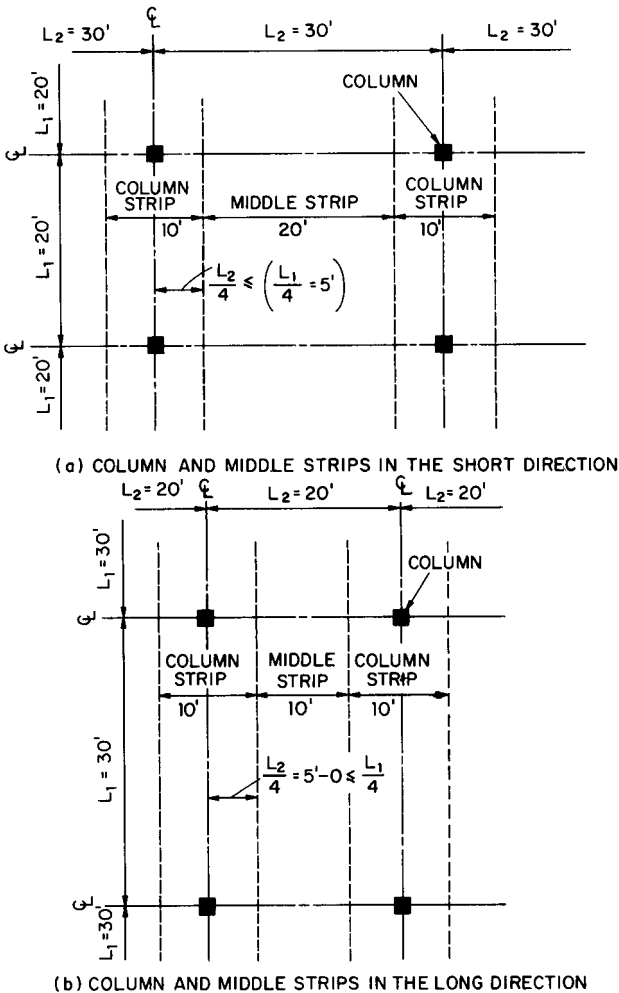

FIGURE 9.28 Division of flat plate into column and middle strips.

Step 5. Check for shear. Shear strength of slabs in the vicinity of columns or other concentrated loads has to be checked for two conditions: when the slab acts as a wide beam and when the load tends to punch through the slab. In the first case, a diagonal crack might extend in a plane across the entire width of the slab. Design for this condition is described in Art. 9.47. For the two-way action of the second condition, diagonal cracking might occur along the surface of a truncated cone or pyramid in the slab around the column.

The critical section for two-way action, therefore, should be taken perpendicular to the plane of the slab at a distance $d/2$ from the periphery of the column, where d is effective depth of slab. Unless adequate shear reinforcement is provided, the factored shear force V_u for punching action must not exceed ϕV_c ; i.e., $V_u \leq \phi V_c$.

where ϕ = strength-reduction factor = 0.85 and V_c is the nominal shear strength of the concrete. V_c is the smallest of the values computed from Eqs. (9.75) to (9.77).

$$V_c = \left(2 + \frac{4}{\beta_c} \right) \sqrt{f'_c} b_o d \quad (9.75)$$

$$V_c = \left[\frac{\alpha_s d}{b_o} + 2 \right] \sqrt{f'_c} b_o d \quad (9.76)$$

$$V_c = 4\sqrt{f'_c} b_o d \quad (9.77)$$

where β_c = ratio of long side to short side of the column

b_o = perimeter of critical section, in.

d = distance from extreme compression surface to centroid of tension reinforcement, in.

α_s = 40 for interior columns; 30 for edge columns; and 20 for corner columns

f'_c = specified compressive strength of the concrete, psi

When shear reinforcement is provided (Art. 9.47), $V_u \leq \phi V_n$, where V_n is the nominal shear strength of the reinforced section and equals the sum of V_c and the shear strength added by the reinforcement. V_n should not exceed $6\sqrt{f'_c} b_o d$. With shearhead reinforcement (steel shapes fabricated by welding with a full-penetration weld into identical perpendicular arms) at interior columns, V_n may be as large as $7\sqrt{f'_c} b_o d$.

Determine the maximum shear at each column for two cases: all panels loaded, and live load on alternate panels for maximum unbalanced moment to the columns. Combine shears due to transfer of vertical load to the column with shear resulting from the transfer of part of the unbalanced moment to the column by eccentricity of shear (Art. 9.59.3). At this point, if the combined shear is excessive, steps 1 through 5 must be repeated with a large column, thicker slab, or higher-strength concrete in the slab; or shear reinforcement must be provided where $V_u > \phi V_c$ (Art. 9.47).

Step 6. When steps 1 through 5 are satisfactory, select flexural reinforcement.

9.59.2 Stiffnesses in Two-Way Construction

The "Commentary" to the ACI 318 Building Code contains references for a sophisticated procedure for computation of stiffnesses of slabs and equivalent columns to determine moments and shears by an elastic analysis. Variations in cross sections of slab and columns, drop panels, capitals, and brackets are taken into account. Columns can be treated as infinitely stiff within the joint with the slab. The slab can be considered to be stiffened somewhat within the depth of the column.

In the direct-design method, certain simplifications are permissible in computation of stiffnesses (see "Commentary" on ACI 318-89).

9.59.3 Transfer of Unbalanced Moments

Design requirements for the transfer of unbalance moment between the slab and columns are included in the ACI 318 Building Code. Consider an exterior-edge

column of a flat plate system where the unbalanced moment, M_u , resulting from gravity loads on the slab, must be transferred to the column. The unbalanced moment is transferred by flexure and by eccentricity of shear.

Part of the unbalanced moment, $\gamma_f M_u$, must be transferred by flexure within an effective slab width equal to the column width plus $1.5h$ on side of the column, i.e., a width of $(c_2 + 1.5h)$ where c_2 is the edge-column width transverse to the direction in which moments are being determined and h is the overall thickness of the slab. The remaining part of the unbalanced moment, $\gamma_v M_u$, must be transferred by eccentricity of shear about the centroid of the critical section which is located at distance of $d/2$ from the column where d is the effective depth of the slab. (As noted in the following discussion, the code supersedes the requirement of designing for $\gamma_v M_u$ by prescribing the magnitude of the gravity load moment to be transferred by eccentricity of shear.) The fractions γ_f and γ_v are calculated

$$\gamma_f = \frac{1}{1 + (2/3) \sqrt{b_1/b_2}} \quad (9.78)$$

$$\gamma_v = (1 - \gamma_f) \quad (9.79)$$

where b_1 = width of critical section measured in the direction in which moments are being determined

b_2 = width of critical section measured in the direction perpendicular to b_1

For a square edge column and square panels, approximately 60% of the unbalanced moment will be transferred by flexure within the slab width $(c_2 + 3h)$ centered on the column centerline. The result is that about 60% of the total top reinforcement required in the column strip must be concentrated within the slab width $(c_2 + 3h)$ at the edge column. The designer must ensure that the top reinforcing bars selected can be physically fitted into the width $(c_2 + 3h)$ within allowable bar spacings, and clearly show the bar spacings and details on the design drawings.

For transfer of gravity load moment from the slab to the edge column by eccentricity of shear, the Code prescribes $\gamma_v(0.3 M_o)$ as the magnitude of the moment to be transferred, rather than $\gamma_v M_u$, where M_o is calculated by Eq. (9.72).

For preliminary design, with square columns flush at edges of the flat plate, a rapid estimate of the shear capacity to allow for effects of combined shear due to gravity loads and to moment transfer can be made by using uniform vertical load w_u only, with nominal strength for factored load as follows:

For edge column, total shear $V_u = 0.5w_u L_2 L_1$ and shear strength $V_c = 2 \sqrt{f'_c} b_o d$

For first interior column, $V_u = 1.15w_u L_2 L_1$ and shear strength $V_c = 4 \sqrt{f'_c} b_o d$

where f'_c = specified concrete compressive strength, psi.

Use of this calculation in establishing a preliminary design is a short cut, which will often avoid the need for repeating steps 1 through 5 in Art. 9.59.1, because it gives a close approximation for final design.

The minimum cantilever edge span of a flat plate so that all columns can be considered interior columns and the direct-design method can be used without tedious stiffness calculations is $1/15$ of the length of the interior span (Fig. 9.29). This result is obtained by equating the minimum cantilever moment at the exterior column to the minimum negative-factored moment at the interior column.

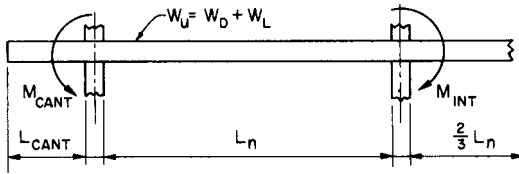

FIGURE 9.29 Length of cantilever (at left) determines whether the exterior column may be treated as an interior column.

9.59.4 Bar Lengths and Details for Flat Plates

The minimum lengths of reinforcing bars for flat plates shown in Fig. 9.30, prescribed by the ACI 318 Building Code, save development (bond) computations. The size of all top bars must be selected so that the tension development length L_d required for the bar size, concrete strength, and grade of the bar is not greater than the length available for development (see Table 9.8).

The size of top bars at the exterior edge must be small enough that the hook plus straight extension to the face of the column is larger than that required for full embedment (Table 9.9).

Column-strip bottom bars in Fig. 9.30 are shown extended into interior columns so that they lap, and one line of bar supports may be used. This anchorage, which

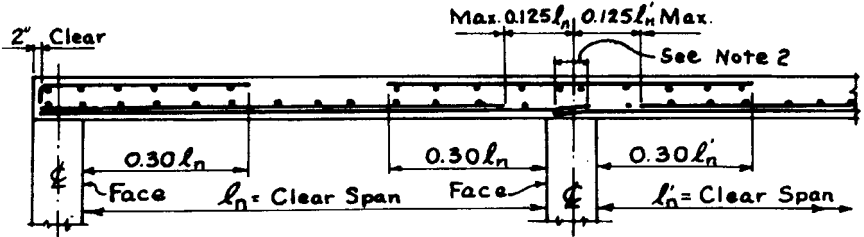

(a) Column Strip

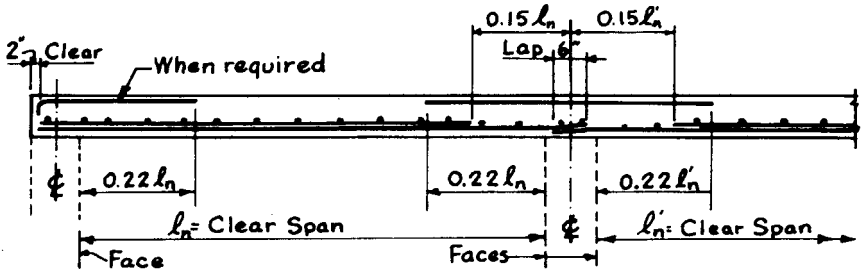

(b) Middle Strip

FIGURE 9.30 Reinforcing bar details for column and middle strips of flat plates.

exceeds ACI 318 Building Code minimum requirements, usually ensures ample development length and helps prevent temperature and shrinkage cracks at the centerline.

Figure 9.24*b* shows weights of steel and concrete for flat plates of normal-weight concrete carrying a superimposed factored load of 170 psf, for preliminary estimates.

Provisions for structural integrity for two-ways slabs specified in the ACI 318 Building Code require all column-strip bottom bars in each direction to be made continuous or spliced with Class A tension lap splices. At least two of the column-strip bottom bars must pass within the column core. The bars must be anchored at exterior supports. In slabs with shearheads, at least two of the bottom bars in each direction must pass through the shearhead as close to the column as possible and be continuous or spliced with a Class A tension lap splice. At exterior columns, the bars must be anchored at the shearhead.

Crack Control. The ACI 318 Building Code's requirements (Art. 9.50) apply only to one-way reinforced elements. For two-way slabs, bar spacing at critical sections should not exceed twice the slab thickness, except in the top slab of cellular or ribbed (waffle) construction, where requirements for temperature and shrinkage reinforcement govern.

9.60 FLAT SLABS

A flat slab is a two-way slab generally of uniform thickness, but it may be thickened or otherwise strengthened in the region of columns by a drop panel, while the top of the column below the slab may be enlarged by a capital (round) or bracket (prismatic). If a drop panel is used to increase depth for negative reinforcement, the minimum side dimensions of this panel are $L_3/3$ and $L_2/3$, where L_1 and L_2 are the center-to-center spans in perpendicular directions. Minimum depth of a drop panel is $1.25h$, where h is the slab thickness elsewhere.

A **waffle flat slab** or **waffle flat plate** consists of a thin, two-way top slab and a grid of joists in perpendicular directions, cast on square dome forms. For strengthening around columns, the domes are omitted in the drop panel areas, to form a solid head, which also may be made deeper than the joists. Other variations of waffle patterns include various arrangements with solid beams on column centerlines both ways. Standard sizes of two-way joist forms are given in Table 9.21.

The drop panel increases shear capacity. Hence, a solid flat slab can ordinarily be designed for concrete of lower strength than for a flat plate. Also, deflection of a flat slab is reduced by the added stiffness that drop panels provide.

The depth of drop panels can be increased beyond $1.25h$ to reduce negative-moment reinforcement and to increase shear capacity when smaller columns are desired. If this adjustment is made, shear in the slab at the edge of the drop panel may become critical. In that case, shear capacity can be increased by making the drop panel larger, up to about 40% of the span. See Fig. 9.31 for bar details (column strip).

Waffle flat plates behave like solid flat slabs with drop panels. Somewhat higher-strength concrete, to avoid the need of stirrups in the joists immediately around the solid head, is usually desirable. If required, however, such stirrups can be made in one piece as a longitudinal assembly, to extend the width of one dome between the

TABLE 9.21 Commonly Used Sizes of Two-Way Joist Forms†

Depth, in	Volume, ft ³ per dome	Weight of displaced concrete, lb per dome	3-in top slab		4½-in top slab	
			Equiv. slab thickness, in	Weight* psf	Equiv. slab thickness, in	Weight* psf
30-in-wide domes						
8	3.85	578	5.8	73	7.3	92
10	4.78	717	6.7	83	8.2	102
12	5.53	830	7.4	95	9.1	114
14	6.54	980	8.3	106	9.9	120
16	7.44	1116	9.1	114	10.6	133
20	9.16	1375	10.8	135	12.3	154
19-in wide domes						
			3-in top slab		4½-in top slab	
8	1.41	211	6.8	85	8.3	103
10	1.90	285	7.3	91	8.8	111
12	2.14	321	8.6	107	10.1	126

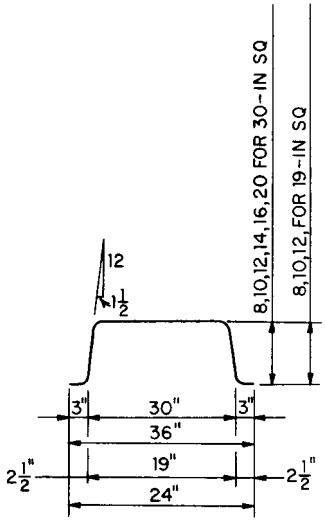

† "Types and Sizes of Forms for Two-Way Concrete-Joist Construction" (ANSI/CRSI A48.2-1986).

*Basis: unit weight of concrete, $w = 150$ pcf.

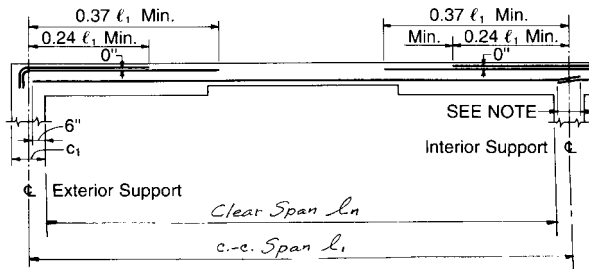

NOTE: Integrity steel is required (ACI 13.3.8.5). All bottom bars in the column strip must be continuous or spliced over the support with Class A tension lap splices. At least two of the column strip bottom bars in each direction must pass within the column core and be anchored at exterior supports.

FIGURE 9.31 Reinforcing bar details for column strips of flat slabs. Details of middle strips are the same as for middle strips of flat plates (Fig. 9.30).

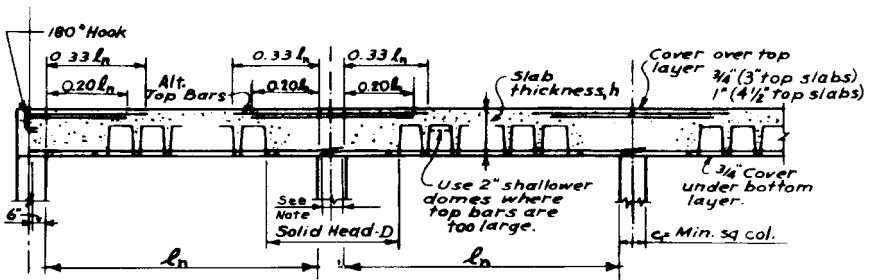

FIGURE 9.32 Reinforcing details for column strips of two-way waffle flat plates. $B = 24$ bar diameters or 12 in minimum. Details for middle strips are the same as for middle strips of flat plates (Fig. 9.30).

drop head and the first transverse joist. For exceptional cases, such stirrups can be used between the second row of domes also. See Fig. 9.32 for reinforcement details.

9.61 TWO-WAY SLABS ON BEAMS

The ACI 318 Building Code provides for use of beams on the sides of panels, on column centerlines. (A system of slabs and beams supported by girders, however, usually forms rectangular panels. In that case, the slabs are designed as one-way slabs.)

Use of beams on all sides of a panel permits use of thinner two-way slabs, down to a minimum thickness $h = 3\frac{1}{2}$ in. A beam may be assumed to resist as much as 85% of the column-strip moment, depending on its stiffness relative to the slab (see the ACI 318 Building Code). A secondary benefit, in addition to the direct advantages of longer spans, thinner slabs, and beam stirrups for shear, is that many local codes allow reduced service live loads for design of the beams. These reductions are based on the area supported and the ratio of dead to live load. For service live loads up to 100 psf, such reductions are usually permitted to a maximum of 60%. Where such reductions are allowed, the reduced total panel moment M_o (Art. 9.59.1)

and the increased effective depth to reinforcing steel in the beams offer savings in reinforcement to offset partially the added cost of formwork for the beams.

9.62 ESTIMATING GUIDE FOR TWO-WAY CONSTRUCTION

Figure 9.33 can be used to estimate quantities of reinforcing steel, concrete, and formwork for flat slabs, as affected by load and span. It also affords a guide to preliminary selection of dimensions for analysis, and can be used as an aid in selecting the structural system most appropriate for particular project requirements.

BEAMS

Most requirements of the ACI 318 Building Code for design of beams and girders refer to flexural members. When slabs and joists are not intended, the Code refers specifically to beams and occasionally to beams and girders, and provisions apply equally to beams and girders. So the single term, beams, will be used in the following.

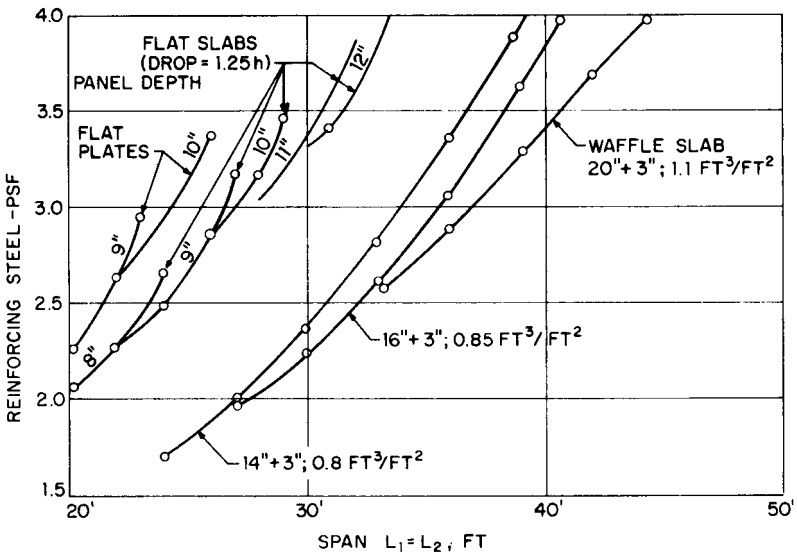

FIGURE 9.33 For estimating purposes, weight of reinforcing steel in square interior panels of flat plates, flat slabs, and waffle flat slabs of 4000-psi concrete, with rebars of 60-ksi yield strength, carrying a superimposed factored load of 200 lb/ft². See also Fig. 9.24.

9.63 DEFINITIONS OF FLEXURAL MEMBERS

The following definitions apply for purposes of this section:

Slab. A flexural member of uniform depth supporting area loads over its surface. A slab may be reinforced for flexure in one or two directions.

Joist-slab. A ribbed slab with ribs in one or two directions. Dimensions of such a slab must be within the ACI 318 Building Code limitations (see Art. 9.54).

Beam. A flexural member designed to carry uniform or concentrated line loads. A beam may act as a primary member in beam-column frames, or may be used to support slabs or joist-slabs.

Girder. A flexural member used to support beams and designed to span between columns, walls, or other girders. A girder is always a primary member.

9.64 FLEXURAL REINFORCEMENT

Nonprestressed beams should be designed for flexure as explained in Arts. 9.44 to 9.46. If beam capacity is inadequate with tension reinforcement only and the capacity must be increased without increasing beam size, additional capacity may be provided by addition of compression bars and more tension-bar area to match the compression forces developable in the compression bars (Fig. 9.14). (Shear, torsion, development, crack control, and deflection requirements must also be met to complete the design. See Arts. 9.47 to 9.51 and 9.65 to 9.67.) Deflection need not be calculated for ACI 318 Building Code purposes if the total depth h of the beam, including top and bottom concrete cover, is at least the fraction of the span L given in Table 9.15.

A number of interdependent complex requirements (Art. 9.49) regulate the permissible cutoff points of bars within a span, based on various formulas and rules for development (bond). An additional set of requirements applies if the bars are cut off in a tensile area. These requirements can be satisfied for cases of uniform gravity load and nearly equal spans for the top bars by extending at least 50% of the top reinforcement to a point in the span $0.30L_n$ beyond the face of the support, and the remainder to a point $0.20L_n$, where L_n = clear span. For the bottom bars, all requirements are satisfied by extending at least 40% of the total reinforcement into the supports 6 in past the face, and cutting off the remainder at a distance $0.125L_n$ from the supports. Note that this arrangement does not cut off bottom bars in a tensile zone. Figure 9.34 shows a typical reinforcement layout for a continuous beam, singly-reinforced.

The structural detailing of reinforcement in beams is also affected by ACI 318 Building Code requirements for structural integrity. Beams are categorized as either *perimeter* beams or *nonperimeter* beams. (A spandrel beam would be a perimeter beam.) In perimeter beams, at least one-sixth of the tension-reinforcement area required for negative moment ($-A_s/6$) at the face of supports, and one-quarter of the tension-reinforcement area required for positive moment ($+A_s/4$) at midspan have to be made continuous around the perimeter of the structure. Closed stirrups are also required in perimeter beams. It is not necessary to place closed stirrups within the joints. It is permissible to provide continuity of the top and bottom bars

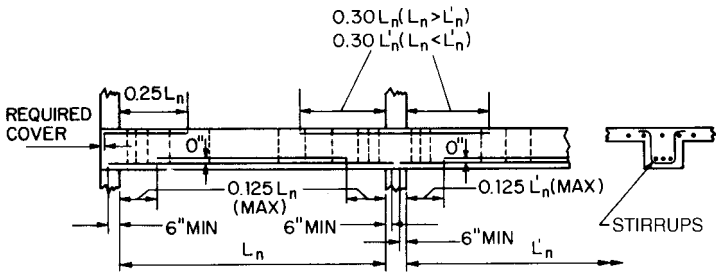

FIGURE 9.34 Reinforcing bar details for uniformly loaded continuous beams. At columns, embed alternate bottom bars (at least 50% of the tension-steel area) a minimum of 6 in., to avoid calculation of development length at $0.125L_n$.

by splicing the top bars at midspan and the bottom bars at or near the supports. Splicing the bars with Class A tension lap splices (Art. 9.49.7) is acceptable. (See Fig. 9.35a.)

For nonperimeter beams, the designer has two choices to satisfy the structural integrity requirements: (1) provide closed stirrups or (2) make at least one-quarter of the tension-reinforcement area required for positive moment ($+A_s/4$) at midspan continuous. Splicing the prescribed number of bottom bars over the supports with Class A tension lap splices is acceptable. At discontinuous ends, the bottom bars must be anchored with standard hooks. (see Fig. 9.35b.)

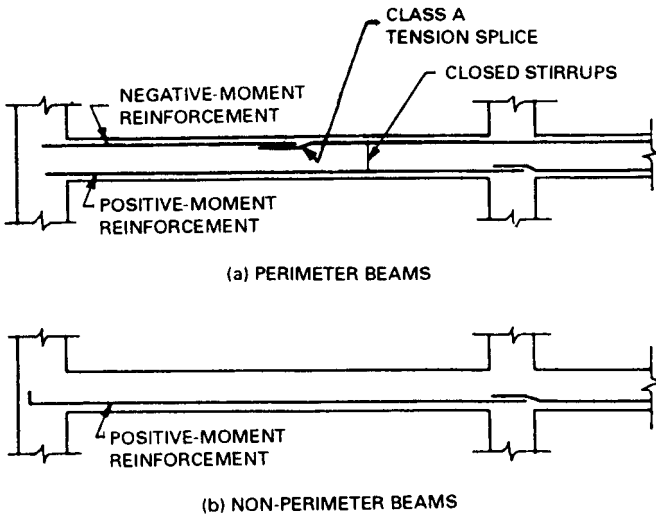

FIGURE 9.35 Reinforcement required to ensure structural integrity of beams. At least one-sixth of the negative-moment rebars and one-fourth of the positive-moment rebars should be continuous around the perimeter of the structure (a), with closed stirrups throughout, except at joints. Class A tension lap splices may be made at midspan. For nonperimeter beams (b), one-fourth the positive-moment rebars should be continuous. For clarity, other rebars are not shown in (a) or (b).

The limit in the ACI 318 Building Code on tension-reinforcement ratio ρ that it not exceed 0.75 times the ratio for balanced conditions applies to beams (Art. 9.46). Balanced conditions in a beam reinforced only for tension exist when the tension steel reaches its yield strength f_y simultaneously with the maximum compressive strain in the concrete at the same section becoming 0.003 in/in. Balanced conditions occur similarly for rectangular beams, and for T-beams with negative moment, that are provided with compression steel, or doubly-reinforced. Such sections are under balanced conditions when the tension steel, with area A_s , yields just as the outer concrete surface crushes, and the total tensile-force capacity $A_s f_y$ equals the total compressive-force capacity of the concrete plus compression steel, with area A'_s . Note that the capacity of the compression steel cannot always be taken as $A'_s f_y$, because the straight-line strain distribution from the fixed points of the outer concrete surface and centroid of the tension steel may limit the compression-steel stress to less than yield strength (Fig. 9.14).

For design of doubly-reinforced beams, the force $A_s f_y$ in the tension steel is limited to three-fourths the compression force in the concrete plus the compression in the compression steel at balanced conditions. For a beam meeting these conditions in which the compression steel has not yielded, the design moment strength is best determined by trial and error:

1. Assume the location of the neutral axis.
2. Determine the strain in the compression steel.
3. See if the total compressive force on the concrete and compression steel equals $A_s f_y$ (Fig. 9.36).

Example. Design a T-beam to resist a negative factored moment of 225 ft-kips. The dimensions of the beam are shown in Fig. 9.36. Concrete strength $f'_c = 4$ ksi, the reinforcing steel has a yield strength $f_y = 60$ ksi, and strength-reduction factor $\phi = 0.90$.

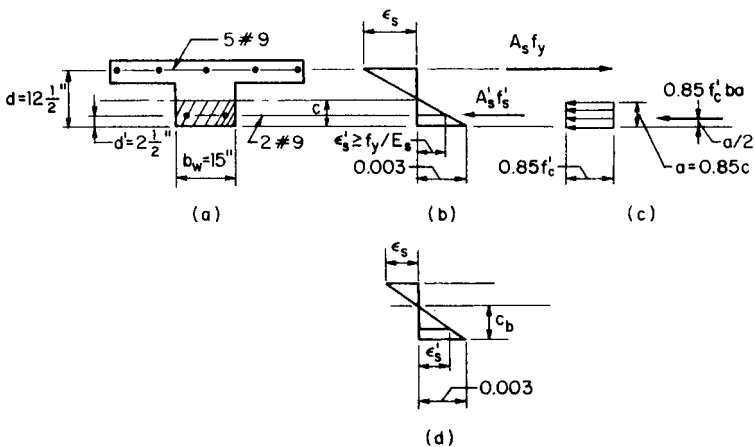

FIGURE 9.36 Stresses and strains in a T-beam reinforced for compression: (a) beam cross section; (b) strain distribution; (c) block distribution of compression stresses; (d) balanced strains.

Need for Compression Steel. To determine whether compression reinforcement is required, first check the strength of the section when it is reinforced only with tension steel. For this purpose, compute the reinforcement ratio ρ_b for balanced conditions from Eq. (9.27) with $\beta_1 = 0.85$:

$$\rho_b = \frac{0.85 \times 4000 \times 0.85}{60,000} \times \frac{87,000}{87,000 + 60,000} = 0.0285$$

The maximum reinforcement ratio permitted by the ACI 318 Building Code is

$$\rho_{\max} = 0.75\rho_b = 0.75 \times 0.0285 = 0.0214$$

and the corresponding steel area is

$$A_s = 0.0214 \times 12.5 \times 15 = 4.01 \text{ in}^2$$

As noted in Art. 9.46.1, depth of the stress block is

$$a = \frac{A_s f_y}{0.85 f'_c b} = \frac{4.01 \times 60,000}{0.85 \times 4000 \times 12.5} = 5.66 \text{ in}$$

From Eq. (9.28b), the maximum design moment strength with tension reinforcement only is

$$\phi M_{n(\max)} = 0.90 \times 4.01 \times 60,000(12.5 - 5.66/2)/12 = 174,500 \text{ ft-lb}$$

The required strength, 225,000 ft-lb, is larger. Hence, compression reinforcement is needed.

Compression on Concrete. (Trial-and-error solution.) Assume that the distance c from the neutral axis to the extreme compression surface is 5.1 in. The depth a then may be taken as $0.85c = 4.33$ in (Art. 9.46). For a rectangular stress distribution over the concrete, the compression force on the concrete is

$$0.85 f'_c b_w a = 0.85 \times 4 \times 15 \times 4.33 = 221 \text{ kips}$$

Selection of Tension Steel. To estimate the tension steel required, assume a moment arm $jd = d - a/2 = 12.5 - 4.33/2 = 10.33$ in. By Eq. (9.28c), the tension-steel force therefore should be about

$$A_s f_y = 60A_s = \frac{M_u}{\phi jd} = \frac{225 \times 12}{0.9 \times 10.33} = 290 \text{ kips}$$

from which $A_s = 4.84 \text{ in}^2$. Select five No. 9 bars, supplying $A_s = 5 \text{ in}^2$ and providing a tensile-steel ratio

$$\rho = \frac{5}{15 \times 12.5} = 0.0267$$

The bars can exert a tension force $A_s f_y = 5 \times 60 = 300$ kips.

Stress in Compression Steel. For a linear strain distribution, the strain ϵ'_s in the steel 2½ in from the extreme compression surface can be found by proportion from the maximum strain of 0.003 in/in at that surface. Since the distance $c = a/\beta_1 = 4.33/0.85 = 5.1$ in,

$$\epsilon'_s = \frac{5.1 - 2.5}{5.1} \times 0.003 = 0.0015 \text{ in/in}$$

With modulus of elasticity E_s taken as 29,000 ksi, the stress in the compression steel is

$$f'_s = 0.0015 \times 29,000 = 43.5 \text{ ksi}$$

Selection of Compression Steel. The total compression force equals the 221-kip force on the concrete previously computed plus the force on the compression steel. If the total compression force is to equal to total tension force, the compression steel must resist a force

$$A'_s f'_s = A'_s (43.5 - 3.4) = 300 - 221 = 79 \text{ kips}$$

from which the compression-steel area $A'_s = 2 \text{ in}^2$. (In the above calculation, the force on the steel is reduced by the force on the concrete, $\phi f'_c A'_s = 0.85 \times 4A'_s = 3.4A'_s$, replaced by the steel.)

Check the Balance of Forces ($\Sigma F_c = \Sigma F_t$). For an assumed position of the neutral axis at 5.10 in with five No. 9 tension bars and two No. 9 compression bars, the total compression force C is

$$\text{Concrete: } 0.85 \times 4 \times 4.33 \times 15 = 221 \text{ kips}$$

$$\text{Steel: } 2(43.5 - 3.4) = \underline{80} \text{ kips}$$

$$C = 301 \text{ kips}$$

This compression force for practical purposes is equal to the total tension force: $5 \times 60 \times 1 = 300$ kips. The assumed position of the neutral axis results in a balance of forces within 1% accuracy.

Nominal Flexural Strength. For determination of the nominal flexural strength of the beam, moments about the centroid of the tension steel are added:

$$M_n = 0.85 f'_c b a \left(d - \frac{a}{2} \right) + A'_s f'_s (d - d') \quad (9.80)$$

Substitution of numerical values gives:

$$\begin{aligned} M_n &= 0.85 \times 4 \times 15 \times 4.33(12.5 - 4.33/2) + 2(43.5 - 3.4)(12.5 - 2.5) \\ &= 221 \times 10.33 + 80 \times 10 = 257 \text{ ft-kips} \end{aligned}$$

Check Design Moment Strength (ϕM_n)

$$\phi M_n = 0.90 \times 257 = 231 \text{ ft-kips} > M_u = 225 \text{ ft-kips} \quad \text{OK}$$

9.65 REINFORCEMENT FOR SHEAR AND FLEXURE

Determination of the shear capacity of a beam is discussed in Art. 9.47. Minimum shear reinforcement is required in all beams with total depth greater than 10 in, or $2\frac{1}{2}$ times flange (slab) thickness, or half the web thickness, except where the fac-

tored shear force V_u is less than half the design shear strength ϕV_c of the concrete alone. Torsion should be combined with shear when the factored loads cause a torsional moment T_u larger than $\phi\sqrt{f'_c} \left(\frac{A_{cp}^2}{P_{cp}} \right)$ for nonprestressed beams (see Art. 9.48).

Shear strength should be computed at critical sections in a beam from Eq. (9.38). Open or closed stirrups may be used as reinforcement for shear in beams; but closed stirrups are required for torsion. The minimum area for open or closed stirrups for vertical shear only, to be used where $0.5\phi V_c \leq V_u \leq \phi V_c$ and the factored torsional moment T_u can be neglected, should be calculated from

$$A_v = \frac{50b_w s}{f_y} \tag{9.81}$$

where A_v = area of all vertical legs in the spacing s , in parallel to flexural reinforcement, in²

b_w = thickness of beam web, in²

f_y = yield strength of reinforcing steel, psi

Note that this minimum area provides a capacity for 50-psi shear on the cross section $b_w s$.

Where V_u exceeds V_c , the cross-sectional area A_v of the legs of open or closed vertical stirrups at each spacing s should be calculated from Eq. (9.40a). A_v is the total area of vertical legs, two legs for a common open U stirrup or the total of all legs for a transverse multiple U. Note that there are three zones in which the required A_v may be supplied by various combinations of size and spacing of stirrups (Fig. 9.37):

1. Beginning 1 or 2 in from the face of supports and extending over a distance d from each support, where d is the depth from extreme compression surface to centroid of tension steel (A_v is based on V_u at d from support).
2. Between distance d from each support and the point where $\phi V_s = V_u - \phi V_c = 50b_w s$ (required A_v decreases from maximum to minimum).
3. Distance over which minimum reinforcement is required (minimum A_v extends from the point where $\phi V_s = 50b_w s$ to the point where $V_u = 0.5\phi V_c$).

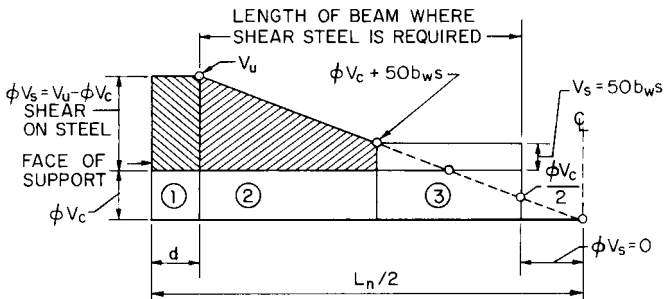

FIGURE 9.37 Required shear reinforcement in three zones of a beam between supports and midspan is determined by cross-hatched areas.

9.66 REINFORCEMENT FOR TORSION AND SHEAR

Any beam that supports unbalanced loads that are transverse to the direction in which it is subjected to bending moments transmits an unbalanced moment to the supports and must be investigated for torsion. Generally, this requirement affects all spandrel and other edge beams, and interior beams supporting uneven spans or unbalanced live loads on opposite sides. The total unbalanced moment from a floor system with one-way slabs in one direction and beams in the perpendicular direction can often be considered to be transferred to the columns by beam flexure in one direction, neglecting torsion in the slab. The total unbalanced moment in the other direction, from the one-way slabs, can be considered to be transferred by torsional shear from the beams to the columns.

Under the ACI 318 Building Code, factored torsional moment, T_u , is resisted by reinforcement (Art. 9.48). No torsion is assumed to be resisted by concrete. When T_u exceeds the value computed by Eq. (9.43) for non-prestressed members, the effects of torsion must be considered.

The required area A_t of each leg of a closed stirrup for torsion should be computed from Eq. (9.48). Stirrup spacing should not exceed $p_h/8$ or 12 in, where p_h is the perimeter of the centerline of the outermost closed stirrup.

Torsion reinforcement also includes the longitudinal bars shown in each corner of the closed stirrups in Fig. 9.16 and the longitudinal bars spaced elsewhere inside the perimeter of the closed stirrups at not more than 12 in. At least one longitudinal bar in each corner is required. [For required areas of these bars, see Eqs. (9.50) and (9.52).] If a beam is fully loaded for maximum flexure and torsion simultaneously, as in a spandrel beam, the area of torsion-resisting longitudinal bars A_l should be provided in addition to flexural bars.

For interior beams, maximum torsion usually occurs with live load only on a slab on one side of the beam. Maximum torsion and maximum flexure cannot occur simultaneously. Hence, the same bars can serve for both.

The closed stirrups required for torsion should be provided in addition to the stirrups required for shear, which may be the open type. Because the size of stirrups must be at least No. 3 and maximum spacings are established in the ACI 318 Building Code for both shear and torsion stirrups, a closed-stirrup size-spacing combination can usually be selected for combined shear and torsion. Where maximum shear and torsion cannot occur under the same loading, the closed stirrups can be proportioned for the maximum combination of forces or the maximum single force; whichever is larger.

9.67 CRACK CONTROL IN BEAMS

The ACI 318 Building Code contains requirements limiting flexural reinforcement spacing to regulate crack widths when the yield strength f_y of the reinforcement exceeds 40,000 psi (Art. 9.50). Crack width is proportional to steel stress. The tensile area of concrete tributary to and concentric with each bar, and thickness of the concrete cover are important to crack control. The minimum concrete cover requirements of the ACI 318 Building Code for reinforcement in beams and girders are given in Table 9.22.

TABLE 9.22 Minimum Concrete Cover, in., for Beams and Girders

Bar size No.	Exposed to Earth or weather			Not exposed to weather or in contact with ground		
	Cast-in-place concrete	Precast concrete	Prestressed concrete	Cast-in-place concrete	Precast concrete	Prestressed concrete
3, 4, and 5	1½	1¼	1½	1½	5/8	1½
6 through 11	2	1½	1½	1½	d_b^*	1½
14 and 18	2	2	1½	1½	1½	1½
Stirrups	Same as above for each size				3/8	1

* d_b = nominal bar diameter, in.

WALLS

Generally, any vertical member whose length and height are both much larger than the thickness may be treated as a wall. Walls subjected to vertical loads are called **bearing walls**. Walls subjected to no loads other than their own weight, such as panel or enclosure walls, are called **nonbearing walls**. Walls with a primary function of resisting lateral loads are called **shear walls**. They also may serve as bearing walls. See Art. 9.89.

9.68 BEARING WALLS

Reinforced concrete bearing walls may be designed as eccentrically loaded columns or by an empirical method given in the ACI 318 Building Code. The empirical method may be used when the resultant of the applied load falls within the middle third of the wall thickness. This method gives the capacity of the walls as

$$P_u \leq \phi P_{nw} = 0.55\phi f'_c A_g \left[1 - \left(\frac{kL_c}{32h} \right)^2 \right] \quad (9.82)$$

- where f'_c = specified concrete compressive strength
- ϕ = strength-reduction factor = 0.70
- A_g = gross area of horizontal cross-section of wall
- h = wall thickness
- L_c = vertical distance between supports
- k = effective length factor

When the wall is braced against lateral translation at top and bottom:

- $k = 0.8$ for restraint against rotation at one or both ends
- $k = 1.0$ for both ends unrestrained against rotation

When the wall is not braced against lateral translation, $k = 2.0$ (cantilever walls).

The allowable average compressive stress f_c for a wall is obtained by dividing P_u in Eq. (9.82) by A_g .

Length. The effective length of wall for concentrated loads may be taken as the center-to-center distance between loads, but not more than the width of bearing plus 4 times the wall thickness.

Thickness. The minimum thickness of bearing walls for which Eq. (9.82) is applicable is one-twenty-fifth of the least distance between supports at the sides or top, but not less than 4 in. Exterior basement walls and foundation walls should be at least $7\frac{1}{2}$ in thick. Minimum thickness and reinforcement requirements may be waived, however, if justified by structural analysis.

Reinforcement. The area of horizontal steel reinforcement should be at least

$$A_h = 0.0025A_{wv} \quad (9.83)$$

where A_{wv} = gross area of the vertical cross-section of wall.

Area of vertical reinforcement should be at least

$$A_v = 0.0015A_{wh} \quad (9.84)$$

where A_{wh} = gross area of the horizontal cross-section of wall. For Grade 60 bars, No. 5 or smaller, or for welded-wire fabric, these steel areas may be reduced to $0.0020A_{wv}$ and $0.0012A_{wh}$, respectively.

Walls 10 in or less thick may be reinforced with only one rectangular grid of rebars. Thicker walls require two grids. The grid nearest the exterior wall surface should contain between one-half and two-thirds the total steel area required for the wall. It should have a concrete cover of at least 2 in but not more than one-third the wall thickness. A grid near the interior wall surface should have a concrete cover of at least $\frac{3}{4}$ in but not more than one-third the wall thickness. Minimum size of bars, if used, is No. 3. Maximum bar spacing is 18 in. (These requirements do not apply to basement walls, however. If such walls are cast against and permanently exposed to earth, minimum cover is 3 in. Otherwise, the cover should be at least 2 in for bar sizes No. 6 and larger, and $1\frac{1}{2}$ in for No. 5 bars or $\frac{5}{8}$ -in wire and smaller.)

At least two No. 5 bars should be placed around all window and door openings. The bars should extend at least 24 in beyond the corners of openings.

Design for Eccentric Loads. Bearing walls with bending moments sufficient to cause tensile stress must be designed as columns for combined flexure and axial load, including slenderness effects if applicable. Minimum reinforcement areas and maximum bar spacings are the same as for walls designed by the empirical method. Lateral ties, as for columns, are required for compression reinforcement and where the vertical bar area exceeds 0.01 times the gross horizontal concrete area of the wall. (For column capacity, see Art. 9.82.)

Under the preceding provisions, a thin, wall-like (rectangular) column with a steel ratio less than 0.01 will have a greater carrying capacity if the bars are detailed as for walls. The reasons for this are: The effective depth is increased by omission of ties outside the vertical bars and by the smaller cover (as small as $\frac{3}{4}$ in) permitted for vertical bars in walls. Furthermore, if the moment is low (eccentricity less than one-sixth the wall thickness), so that the wall capacity is determined by Eq. (9.82), the capacity will be larger than that computed for a column, except where the column is part of a frame braced against sidesway.

If slenderness effects need to be considered, slender walls must comply with the slenderness requirements for columns (Art. 9.86). For slender precast concrete wall panels, where the panels are restrained at the top, an alternative design procedure can be used. The alternative approach was introduced into Chapter 14 of the ACI 318-99 Building Code. Complying with the provisions in the alternative procedure is deemed to satisfy the Code's slenderness requirements for columns.

9.69 NONBEARING WALLS

Nonbearing reinforced-concrete walls, frequently classified as panels, partitions, or cross walls, may be precast or cast in place. Panels serving merely as exterior cladding, when precast, are usually attached to the columns or floors of a frame, supported on grade beams, or supported by and spanning between footings, serving as both grade beams and walls. Cast-in-place cross walls are most common in substructures. Less often, cast-in-place panels may be supported on grade beams and attached to the frame.

In most of these applications for nonbearing walls, stresses are low and alternative materials, such as unreinforced masonry, when supported by beams above grade, or panels of other materials, can be used. Consequently, unless esthetic requirements dictate reinforced concrete, low-stressed panels of reinforced concrete must be designed for maximum economy. Minimum thickness, minimum reinforcement, full benefits of standardization for mass-production techniques, and design for double function as both wall and deep beam must be achieved.

Thickness of nonbearing walls of reinforced concrete should be at least one-thirtieth the distance between supports, but not less than 4 in.

The ACI 318 Building Code, however, permits waiving all minimum arbitrary requirements for thickness and reinforcement where structural analysis indicates adequate strength and stability.

Where support is provided, as for a panel above grade on a grade beam, connections to columns may be detailed to permit shrinkage. Friction between base of panel and the beam can be reduced by an asphalt coating and omission of dowels. These provisions will permit elimination or reduction of horizontal shrinkage reinforcement. Vertical reinforcement is seldom required, except as needed for spacing the horizontal bars.

If a nonbearing wall is cast in place, reinforcement can be nearly eliminated except at edges. If the wall is precast, handling stresses will often control. Multiple pickup points with rigid-beam pickups will reduce such stresses. Vacuum pad pickups can eliminate nearly all lifting stresses.

Where deep-beam behavior or wind loads cause stresses exceeding those permitted on plain concrete, the ACI 318 Building Code permits reduction of minimum tension-reinforcement [$A_s = 200bd/f_y$ (Art. 9.46)] if reinforcement furnished is one-third greater than that required by analysis. (For deep-beam design, see Art. 9.88.)

9.70 CANTILEVER RETAINING WALLS

Under the ACI 318 Building Code, cantilever retaining walls are designed as slabs. Specific Code requirements are not given for cantilever walls, but when axial load becomes near zero, the Code requirements for flexure apply.

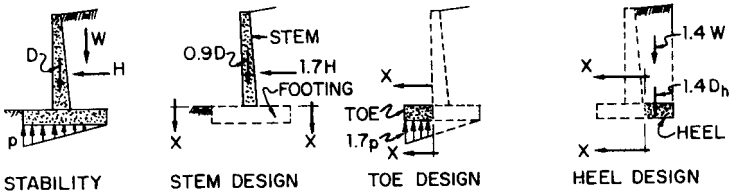

FIGURE 9.38 Factored loads and critical sections for design of cantilever retaining walls.

Minimum clear cover for bars in walls cast against and permanently exposed to earth is 3 in. Otherwise, minimum cover is 2 in. for bar sizes No. 6 and larger, and 1½ for No. 5 bars or 5/8-in wire and smaller.

Two points requiring special consideration are analysis for load factors of 1.7 times lateral earth pressure and 1.4 times dead loads and fluid pressures, and provision of splices at the base of the stem, which is a point of maximum moment. The footing and stem are usually cast separately, and dowels left projecting from the footing are spliced to the stem reinforcement.

A straightforward way of applying Code requirements for strength design is illustrated in Fig. 9.38. Soil reaction pressure p and stability against overturning are determined for actual weights of concrete D and soil W and assumed lateral pressure of the soil H . The total cantilever bending moment for design of stem reinforcement is then based upon $1.7H$. The toe pressure used to determine the footing bottom bars is $1.7p$. And the top load for design of the top bars in the footing heel is $1.4(W + D_h)$, where D_h is the weight of the heel. The Code requires application of a factor of 0.9 to vertical loading that reduces the moment caused by H .

Where the horizontal component of backfill pressure includes groundwater above the top of the heel, use of two factors, 1.7 for the transverse soil pressure and 1.4 for the transverse liquid pressure, would not be appropriate. Because the probability of overload is about the same for soil pressure and water pressure, use

of a single factor, 1.7, is logical, as recommended in the Commentary to the ACI 318 Building Code. For environmental engineering structures where these conditions are common, ACI Committee 350 had recommended use of 1.7 for both soil and liquid pressure (see "Environmental Engineering Concrete Structures," ACI 350R). Committee 350 also favored a more conservative approach for design of the toe. It is more convenient and conservative to consider 1.7 times the entire vertical reaction uniformly distributed across the toe as well as more nearly representing the actual end-point condition (Fig. 9.39).

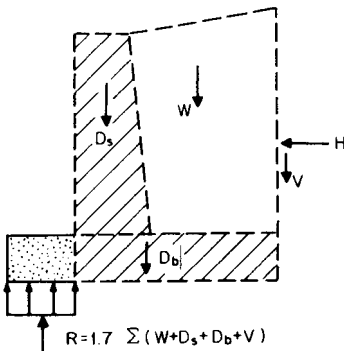

FIGURE 9.39 Loads for simplified strength design for toe of wall.

The top bars in the heel can be selected for the unbalanced moment between the factored forces on the toe and the stem, but need not be larger than for the moment of the top loads on the footing

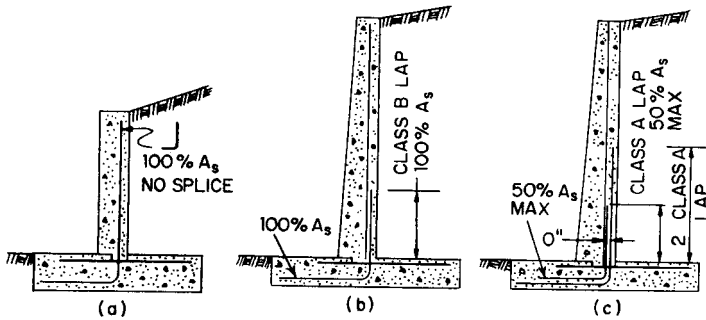

FIGURE 9.40 Splice details for cantilever retaining walls: (a) for low walls; (b) for high walls with Class B lap for dowels; (c) alternative details for high walls, with Class A lap for dowels.

(earth and weight of heel). For a footing proportioned so that the actual soil pressure approaches zero at the end of the heel, the unbalanced moment and the maximum moment in the heel caused by the top loads will be nearly equal.

The possibility of an overall sliding failure, involving the soil and the structure together, must be considered, and may require a vertical lug extending beneath the footing, tie backs, or other provisions.

The base of the stem is a point of maximum bending moment and yet also the most convenient location for splicing the vertical bars and footing dowels. The ACI 318 Building Code advises avoiding such points for the location of lap splices. But for cantilever walls, splices can be avoided entirely at the base of the stem only for low walls (8 to 10 ft high), in which L-shaped bars from the base of the toe can be extended full height of the stem. For high retaining walls (over 10 ft high), if all the bars are spliced at the base of the stem, a Class B tension lap splice is required (Art. 9.49.7). If alternate dowel bars are extended one Class A tension lap-splice length and the remaining dowel bars are extended at least twice this distance before cutoff, Class A tension lap splices may be used. This arrangement requires that dowel-bar sizes and vertical-bar sizes be selected so that the longer dowel bars provide at least 50% of the steel area required at the base of the stem and the vertical bars provide the total required steel at the cutoff point of the longer dowels (Fig. 9.40).

9.71 COUNTERFORT RETAINING WALLS

In this type of retaining wall, counterforts (cantilevers) are provided on the earth side between wall and footing to support the wall, which essentially spans as a continuous one-way slab horizontally. Counterfort walls seldom find application in building construction. A temporary condition in which basement walls may be required to behave as counterfort retaining walls occurs though, if outside fill is placed before the floors are constructed. Under this condition of loading, each interior cross wall and end basement wall can be regarded as a counterfort. It is usually preferable, however, to delay the fill operation rather than to design and provide reinforcement for this temporary condition.

The advantages of counterfort walls are the large effective depth for the cantilever reinforcement and concrete efficiently concentrated in the counterfort. For very tall walls, where an alternative cantilever wall would require greater thickness and larger quantities of reinforcing steel and concrete, the savings in material will exceed the additional cost of forming the counterforts. Accurate design is necessary for economy in important projects involving large quantities of material and requires refinement of the simple assumptions in the definition of counterfort walls. The analysis becomes complex for determination of the division of the load between one-way horizontal slab and vertical cantilever action.

See also Art. 6.7 (F. S. Merritt, "Standard Handbook for Civil Engineers," McGraw-Hill Publishing Company, New York.)

9.72 RETAINING WALLS SUPPORTED ON FOUR SIDES

For walls more than 10 in thick, the ACI 318 Building Code requires two-way layers of bars in each face. Two-way slab design of this reinforcement is required for economy in basement walls or subsurface tank walls supported as vertical spans by the floor above and the footing below, and as horizontal spans by stiff pilasters, interior cross walls, or end walls.

This type of two-way slab is outside the scope of the specific provisions in the Code. Without an "exact" analysis, which is seldom justified because of the uncertainties involved in the assumptions for stiffnesses and loads, a realistic design can be based on the simple two-way slab design method of Appendix A, Method 2, of the 1963 ACI 318 Building Code.

FOUNDATIONS

Building foundations should distribute wall and column loads to the underlying soil and rock within acceptable limits on resulting soil pressure and total and differential settlement. Wall and column loads consist of live load, reduced in accordance with the applicable general building code, and dead load, combined, when required, with lateral loads of wind, earthquake, earth pressure, or liquid pressure. These loads can be distributed to the soil near grade by concrete spread footings, or to the soil at lower levels by concrete piles or drilled piers.

9.73 TYPES OF FOUNDATIONS

A wide variety of concrete foundations are used for buildings. Some of the most common types are illustrated in Fig. 9.41.

Spread wall footings consist of a plain or reinforced slab wider than the wall, extending the length of the wall (Fig. 9.41*a*). Plain- or reinforced-concrete **individual-concrete spread footings** consist of simple, stepped, or sloped two-way concrete slabs, square or rectangular in plan (Fig. 9.41*b* to *d*). For two columns close together, or an exterior column close to the property line so that individual spread or pile-cap footings cannot be placed concentrically, a reinforced-concrete, spread

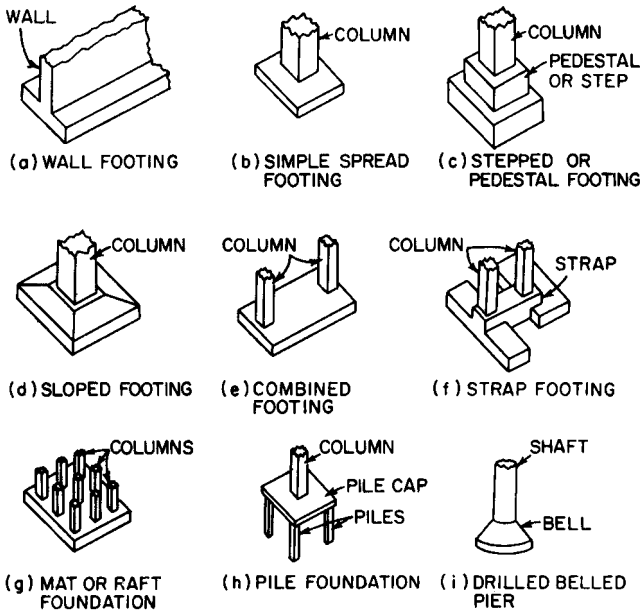

FIGURE 9.41 Common types of foundations for buildings.

combined footing (Fig. 9.41e) or a **strap footing** (Fig. 9.41f) can be used to obtain a nearly uniform distribution of soil pressure or pile loads. The strap footing becomes more economical than a combined footing when the spacing between the columns becomes larger, causing large bending moments in the combined footing.

For small soil pressures or where loads are heavy relative to the soil capacity, a reinforced-concrete **mat**, or **raft foundation** (Fig. 9.41g) may prove economical. A mat consists of a two-way slab under the entire structure. Concrete cross walls or inverted beams can be utilized with a mat to obtain greater stiffness and economy.

Where sufficient soil strength is available only at lower levels, **pile foundations** (Fig. 9.41h) or **drilled-pier foundations** (Fig. 9.41i) can be used.

9.74 GENERAL DESIGN PRINCIPLES FOR FOUNDATIONS

The area of spread footings, the number of piles, or the number of drilled piers are selected by a designer to support actual unfactored building loads without exceeding *settlement limitations*, a safe soil pressure q_u , or a safe pile or drilled-pier load. A factor of safety from 2 to 3, based on the ultimate strength of the soil and its settlement characteristics, is usually used to determine the safe soil pressure or safe pile or drilled-pier load. See Art. 6.8.

Soil Pressures. After the area of the spread footing or the number and spacing of piles or drilled piers has been determined, the spread footing, pile-cap footing, or drilled pier can be designed. The strength-design method of the ACI 318 Build-

ing Code (Art. 9.44) uses factored loads of gravity, wind, earthquake, earth pressure, and fluid pressure to determine *factored soil pressure* q_s , and factored pile or pier load. The factored loadings are used in strength design to determine factored moments and shears at critical sections.

For concentrically loaded footings, q_s is usually assumed as uniformly distributed over the footing area. This pressure is determined by dividing the concentric wall or column factored load P_u by the area of the footing. The weight of the footing can also be neglected in determining q_s because the weight does not induce factored moments and shears. The factored pile load for concentrically loaded pile-cap footings is determined in a similar manner.

When individual or wall spread footings are subjected to overturning moment about one axis, in addition to vertical load, as with a spread footing for a retaining wall, the pressure distribution under the footing is trapezoidal if the eccentricity e_x , of the resultant vertical load P_u is within the kern of the footing, or triangular if beyond the kern, as shown in Fig. 9.42. Thus, when $e_x < L/6$, where L is the footing length in the direction of eccentricity e_x , the pressure distribution is trapezoidal (Fig. 9.42a) with a maximum

$$q_{s1} = \frac{P_u}{BL} \left(1 + \frac{6e_x}{L} \right) \tag{9.85}$$

and a minimum

$$q_{s2} = \frac{P_u}{BL} \left(1 - \frac{6e_x}{L} \right) \tag{9.86}$$

where B = footing width. When $e_x = L/6$, the pressure distribution becomes triangular over the length L , with a maximum

$$q_s = \frac{2P_u}{BL} \tag{9.87}$$

When $e_x > L/6$, the length of the triangular distribution decreases to $1.5L - 3e_x$ (Fig. 9.42b) and the maximum pressure rises to

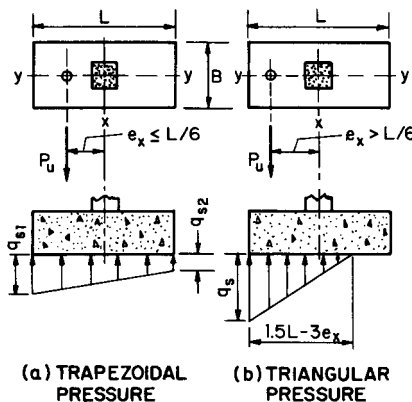

FIGURE 9.42 Spread footing subjected to moment pressures.

$$q_s = \frac{2P_u}{1.5B(L - 2e_s)} \tag{9.88}$$

Reinforcement for Bearing. The bearing stress on the interface between a column and a spread footing, pile cap, or drilled pier should not exceed the allowable stress f_b given by Eq. (9.89), unless vertical reinforcement is provided for the excess.

$$f_b = 0.85\phi f'_c \sqrt{\frac{A_2}{A_1}}; \frac{A_2}{A_1} \leq 4 \tag{9.89}$$

where ϕ = strength-reduction factor = 0.70

f'_c = specified concrete compressive strength

A_1 = loaded area of the column or base plate

A_2 = supporting area of footing, pile cap, or drilled pier that is the lower base of the largest frustum of a right pyramid or cone contained wholly within the footing, with A_1 the upper face, and with side slopes not exceeding 2 horizontal to 1 vertical (Fig. 9.43).

If the bearing stress on the loaded area exceeds f_b , reinforcement must be provided by extending the longitudinal column bars into the spread footing, pile cap, or drilled pier or by dowels. If so, the column bars or dowels required must have a minimum area of 0.005 times the loaded area of the column.

Provisions in the ACI 318 Building Code assure that every column will have a minimum tensile capacity. Compression lap splices, which are permitted when the column bars are always in compression for all loading conditions, are considered to have sufficient tensile capacity so that no special requirements are needed. Similarly, the required dowel embedment in the footing for full compression development will provide a minimum tensile capacity.

Required compression-dowel embedment length cannot be reduced by end hooks. Compression dowels can be smaller than column reinforcement. They cannot be larger than No. 11 bars.

If the bearing stress on the loaded area of a column does not exceed $0.85\phi f'_c$, column compression bars or dowels do not need to be extended into the footing, pile cap, or pier, if they can be developed within 3 times the column dimension (pedestal height) above the footing (Art. 9.49.8). It is desirable, however, that a minimum of one No. 5 dowel be provided in each corner of a column.

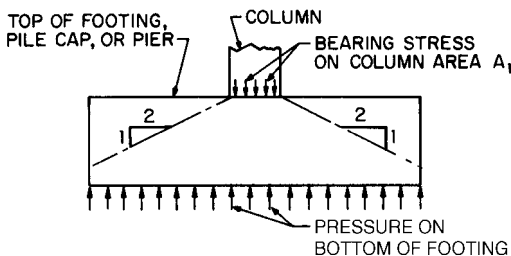

FIGURE 9.43 Bearing stresses on column and pressure against bottom of footing.

Footing Thickness. The minimum thickness allowed by the ACI 318 Building Code for footing is 8 in for plain concrete footings on soil, 6 in above the bottom reinforcement for reinforced-concrete footings on soil, and 12 in above the bottom reinforcement for reinforced-concrete footings on piles. Plain-concrete pile-cap footings are not permitted.

Concrete Cover. The minimum concrete cover required by the ACI 318 Building Code for reinforcement cast against and permanently exposed to earth is 3 in.

9.75 SPREAD FOOTINGS FOR WALLS

The critical sections for shear and moment for spread footings supporting concrete or masonry walls are shown in Fig. 9.44a and b. Under the soil pressure, the projection of footing on either side of a wall acts as a one-way cantilever slab.

Unreinforced Footings. Requirements for design of unreinforced concrete footings are included in the ACI 318 Building Code. For plain-concrete spread footings, the maximum permissible flexural tension stress, psi, in the concrete is limited to $5\phi\sqrt{f'_c}$, where ϕ = strength-reduction factor = 0.65 and f'_c = specified concrete compressive strength, psi. For constant-depth, concentrically loaded footings with uniform factored soil pressure q_s and neglecting the weight of the projection of the footing, the thickness h , in, can be calculated from

$$h = 0.08X \sqrt{\frac{q_s}{\sqrt{f'_c}}} \tag{9.90}$$

where X = projection of footing, in and q_s = net factored soil pressure, psf.

Shear is not critical for plain-concrete wall footings. The maximum tensile stress, $\phi 5\sqrt{f'_c}$, due to flexure controls the thickness.

Reinforced Footings. Because it is usually not economical or practical to provide shear reinforcement in reinforced-concrete spread footings for walls, V_u is usually limited to the maximum value that can be carried by the concrete, $\phi V_c = \phi 2\sqrt{f'_c}b_w d$.

Area of flexural reinforcement can be determined from $A_s = M_u / \phi f_y j d$ as in-

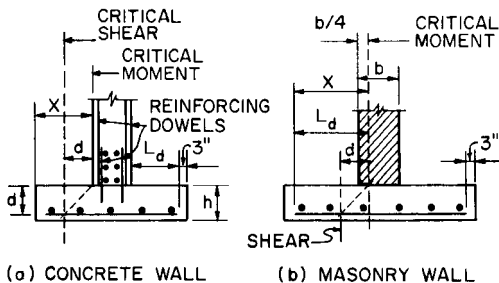
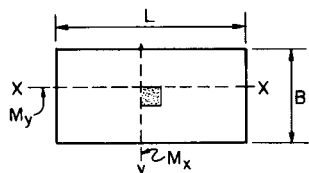

FIGURE 9.44 Critical sections for factored shear and moment in wall footings.

indicated in Art. 9.46. Sufficient length of reinforcement must be provided to develop the full yield strength of straight tension reinforcement. The critical development length is the shorter dimension L_d shown in Fig. 9.44a and b. The minimum lengths required to develop various bar sizes are tabulated in Table 9.8 (Art. 9.49.4). Reinforcement at right angles to the flexural reinforcement is usually provided as shrinkage and temperature reinforcement and to support and hold the flexural bars in position.

9.76 SPREAD FOOTINGS FOR INDIVIDUAL COLUMNS

Footings supporting columns are usually made considerably larger than the columns to keep pressure and settlement within reasonable limits. Generally, each column is also placed over the centroid of its footing to obtain uniform pressure distribution under concentric loading. In plan, the footings are usually square, but they can be made rectangular to satisfy space restrictions or to support rectangular columns or pedestals.



(a) MOMENT SECTIONS

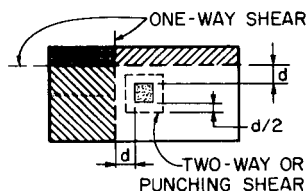

(b) SHEAR SECTIONS

FIGURE 9.45 Critical sections for shear and moment in column footings.

the flexural tensile stress must be limited to a maximum of $5\phi\sqrt{f'_c}$, where ϕ = strength-reduction factor = 0.65 and $\sqrt{f'_c}$ = specified concrete compressive strength psi. Thickness of such footings can be calculated with Eq. (9.90). Shear is not critical for plain-concrete footings.

Shear. For reinforced-concrete spread footings, shear is critical on two different sections.

Two-way or punching shear (Fig. 9.45b) is critical on the periphery of the surfaces at distance $d/2$ from the column, where d = effective footing depth.

One-way shear, as a measure of diagonal tension, is critical at distance d from the column (Fig. 9.45b), and must be checked in each direction.

Under soil pressure, the projection on each side of a column acts as a cantilever slab in two perpendicular directions. The effective depth of footing d is the distance from the extreme compression surface of the footing to the centroid of the tension reinforcement.

Bending Stresses. Critical sections for moment are at the faces of square and rectangular concrete columns or pedestals (Fig. 9.45a). For round and regular polygon columns or pedestals, the face may be taken as the side of a square having an area equal to the area enclosed within the perimeter of the column or pedestal. For structural steel columns with steel base plates, the critical section for moment may be taken half-way between the face of the column and the edges of the plate.

For plain-concrete spread footings,

It is usually not economical or practical to provide shear reinforcement in column footings. So the shear ϕV_c that can be carried by the concrete controls the thickness required.

For one-way shear for plain or reinforced concrete sections,

$$V_c = 2\sqrt{f'_c}b_wd \quad (9.91)$$

where b_w = width of section

d = effective depth of section

but Eq. (9.39) may be used as an alternative for reinforced concrete.

For two-way shear, V_c is the smallest of the values computed from Eqs. (9.75) to (9.77).

Flexural Reinforcement. In square spread footings, reinforcing steel should be uniformly spaced throughout, in perpendicular directions. In rectangular spread footings, the ACI 318 Building Code requires the reinforcement in the long direction to be uniformly spaced over the footing width. Also, reinforcement with an area $2/(\beta + 1)$ times the area of total reinforcement in the short direction should be uniformly spaced in a width that is centered on the column and equal to the short footing dimension, where β is the ratio of the long to the short side of the footing. The remainder of the reinforcement in the short direction should be uniformly spaced in the outer portions of the footing. To maintain a uniform spacing for the bars in the short direction for simplified placing, the theoretical number of bars required for flexure must be increased by about 15%. The maximum increase occurs when β is about 2.5.

The required area of flexural reinforcement can be determined as indicated in Art. 9.46. Maximum-size bars are usually selected to develop the yield strength by straight tension embedment without end hooks. The critical length is the shorter dimension L_d shown for wall footings in Figs. 9.44a and b.

9.77 COMBINED SPREAD FOOTINGS

A combined spread footing under two columns should have a shape and location such that the center of gravity of the column loads coincides with the centroid of the footing area. It can be square, rectangular, or trapezoidal, as shown in Fig. 9.46.

Net design soil-pressure distribution can be assumed to vary linearly for most (rigid) combined footings. For the pressure distribution for flexible combined footings, see the report, "Suggested Analysis and Design Procedures for Combined Footings and Mats," ACI 336.2R, American Concrete Institute.

If the center of gravity of the unfactored column loads coincides with the centroid of the footing area, the net soil pressure q_a will be uniform.

$$q_a = \frac{R}{A_f} \quad (9.92)$$

where R = applied vertical load

A_f = area of footing

The factored loads on the columns, however, may change the location of the center of gravity of the loads. If the resultant is within the kern for footings with

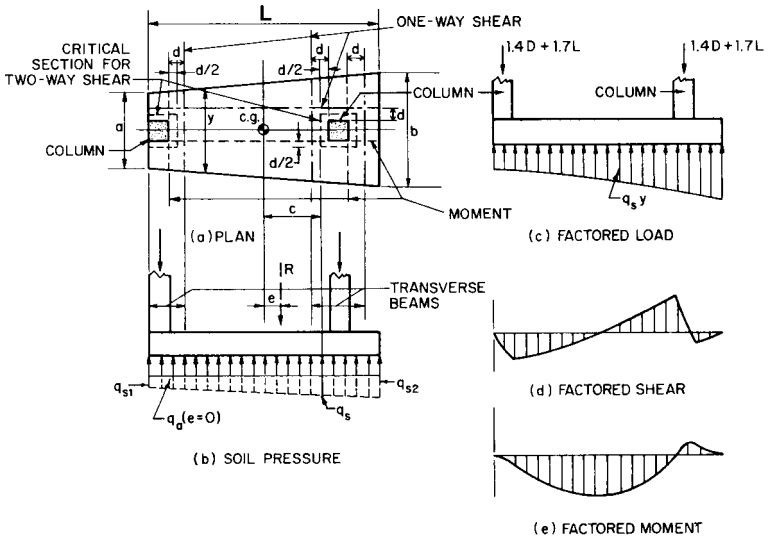

FIGURE 9.46 Design conditions for combined spread footing of trapezoidal shape.

moment about one axis, the factored soil pressure q_s can be assumed to have a linear distribution (Fig. 9.46b) with a maximum at the more heavily loaded edge:

$$q_{s1} = \frac{P_u}{A_f} + \frac{P_u e c}{I_f} \tag{9.93}$$

and a minimum at the opposite edge:

$$q_{s2} = \frac{P_u}{A_f} - \frac{P_u e c}{I_f} \tag{9.94}$$

where P_u = factored vertical load

e = eccentricity of load

c = distance from center of gravity to section for which pressure is being computed

I_f = moment of inertia of footing area

If the resultant falls outside the kern of the footing, the net factored pressure q_s can be assumed to have a linear distribution with a maximum value at the more heavily loaded edge and a lengthwise distribution of 3 times the distance between the resultant and the pressed edge. The balance of the footing will have no net factored pressure.

With the net factored soil-pressure distribution known, the factored shears and moments can be determined (Fig. 9.46d and e). Critical sections for shear and moment are shown in Fig. 9.46a. The critical section for two-way shear is at a distance $d/2$ from the columns, where d is the effective depth of footing. The critical section for one-way shear in both the longitudinal and transverse direction is at a distance d from the column face.

Maximum negative factored moment, causing tension in the top of the footing, will occur between the columns. The maximum positive factored moment, with tension in the bottom of the footing, will occur at the face of the columns in both the longitudinal and transverse direction.

Flexural reinforcement can be selected as shown in Art. 9.46. For economy, combined footings should be made deep enough to avoid the use of stirrups for shear reinforcement. In the transverse direction, the bottom reinforcement is placed uniformly in bands having an arbitrary width, which can be taken as the width of the column plus $2d$. The amount at each column is proportional to the column load.

Size and length of reinforcing bars must be selected to develop the full yield strength of the steel between the critical section, or point of maximum tension, and the end of the bar (Art. 9.49.4).

9.78 STRAP FOOTINGS

When the distance between the two columns to be supported on a combined footing becomes large, cost increases rapidly, and a strap footing, or cantilever-type footing, may be more economical. This type of footing, in effect, consists of two footings, one under each column, connected by a strap beam (Fig. 9.47). This beam distributes the column loads to each footing to make the net soil pressure with unfactored

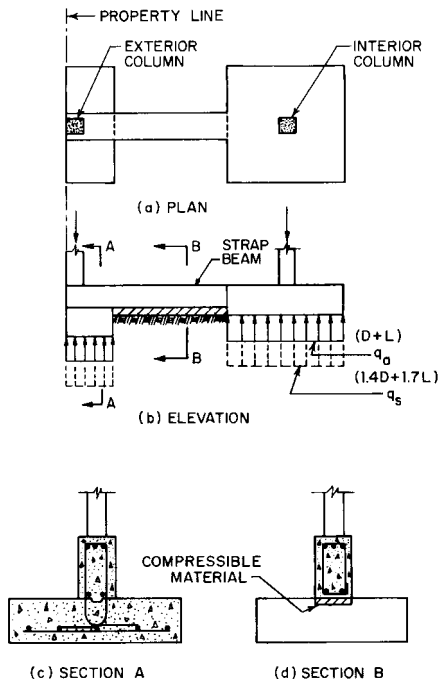

FIGURE 9.47 Design conditions for a strap footing.

loads uniform and equal at each footing, and with factored loads uniform but not necessarily equal. The center of gravity of the actual column loads should coincide with the centroid of the combined footing areas.

The strap beam is usually designed and constructed so that it does not bear on the soil (Fig. 9.47*b*). The concrete for the beam is cast on compressible material. If the concrete for the strap beam were placed on compacted soil, the resulting soil pressure would have to be considered in design of the footing.

The strap beam, in effect, cantilevers over the exterior column footing, and the bending will cause tension at the top. The beam therefore requires top flexural reinforcement throughout its entire length. Nominal flexural reinforcement should be provided in the bottom of the beam to provide for any tension that could result from differential settlement.

The top bars at the exterior column must have sufficient embedment length to develop their full yield strength. If the distance between the interior face of the exterior column and the property-line end of the horizontal portion of the top bar is less than the required straight bar tension development length, the top bars should have standard end hooks to provide proper anchorage (Art. 9.49.5).

Strength-design shear reinforcement [Eq. (9.40*a*)] will be required when $V_u > \phi V_c$, and requirements for minimum shear reinforcement [Eq. (9.81)] must be observed when $V_u > \phi V_c/2$, where V_c = shear carried by the concrete (Art. 9.47).

For the strap footing shown in Fig. 9.47, the exterior column footing can be designed as a wall spread footing, and the interior column footing as an individual-column spread footing (Arts. 9.75 and 9.76).

9.79 MAT FOUNDATIONS

A mat or raft foundation is a single combined footing for an entire building unit. It is economical when building loads are relatively heavy and the safe soil pressure is small (See also Arts. 9.73 and 9.74.)

Weight of soil excavated for the foundation decreases the pressure on the soil under the mat. If excavated soil weighs more than the building, there is a net decrease in pressure at mat level from that prior to excavation.

When the mat is rigid, a uniform distribution of soil pressure can be assumed and the design can be based on a statically determinate structure, as shown in Fig. 9.48. (See "Suggested Analysis and Design Procedures for Combined Footings and Mats," ACI 336.2R, American Concrete Institute.)

If the centroid of the factored loads does not coincide with the centroid of the mat area, the resulting nonuniform soil pressure should be used in the strength design of the mat.

Strength-design provisions for flexure, one-way and two-way shear, development length, and serviceability should conform to ACI 318 Building Code requirements (Art. 9.59).

9.80 PILE FOUNDATIONS

Building loads can be transferred to piles by a thick reinforced-concrete slab, called a pile-cap footing. The piles are usually embedded in the pile cap 4 to 6 in. They

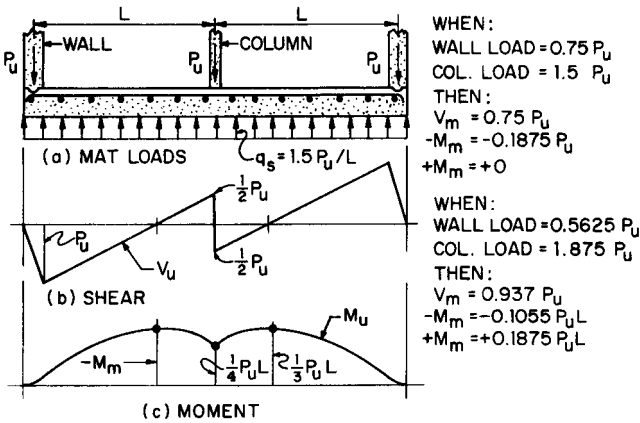

FIGURE 9.48 Design conditions for a rigid mat footing.

should be cut to required elevation after driving and prior to casting the footing. Reinforcement should be placed a minimum of 3 in. clear above the top of the piles. The pile cap is required by the ACI 318 Building Code to have a minimum thickness of 12 in. above the reinforcement. (See also Art. 9.74.)

Piles should be located so that the centroid of the pile cluster coincides with the center of gravity of the column load. As a practical matter, piles cannot be driven exactly to the theoretical design location. A construction survey should be made to determine if the actual locations require modification of the original pile-cap design.

Pile-cap footings are designed like spread footings (Art. 9.76), but for concentrated pile loads. Critical sections for shear and moment are the same. Reaction from any pile with center $d_p/2$ or more inside the critical section, where d_p is the pile diameter at footing base, should be assumed to produce no shear on the section. The ACI 318 Building Code requires that the portion of the reaction of a pile with center within $d_p/2$ of the section be assumed as producing shear on the section based on a straightline interpolation between full value for center of piles located $d_p/2$ outside the section and zero at $d_p/2$ inside the section. For design of pile caps for high-capacity piles, see "CRSI Design Handbook," Concrete Reinforcing Steel Institute.

For pile clusters without moment, the pile load P_u for strength design of the footing is obtained by dividing the factored column load by the number of piles n . The factored load equals $1.4D + 1.7L$, where D is the dead load, including the weight of the pile cap, and L is the live load. For pile clusters with moment, the factored load on the r th pile is

$$P_{ur} = (1.4D + 1.7L) \left(\frac{1}{n} + \frac{eC_r}{\sum_1^n C_r^2} \right) \quad (9.95)$$

where e = eccentricity of resultant load with respect to neutral axis of pile group, in.

C_r = distance between neutral axis of pile group and center of n th pile, in.
 n = number of piles in cluster

9.81 DRILLED-PIER FOUNDATIONS

A drilled-pier foundation is used to transmit loads to soil at lower levels through end bearing and, in some situations, side friction. (See also Art. 9.74.) It can be constructed in firm, dry earth or clay soil by machine excavating an unlined hole with a rotating auger or bucket with cutting vanes and filling the hole with plain or reinforced concrete. Under favorable conditions, pier shafts 12 ft in diameter and larger can be constructed economically to depths of 100 ft and more. Buckets with sliding arms can be used to form bells at the bottom of the shaft with a diameter as great as 3 times that of the shaft (Fig. 9.49).

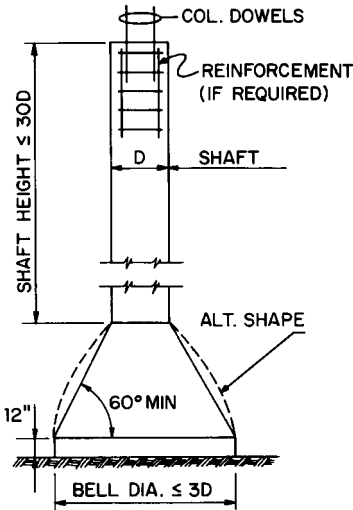

FIGURE 9.49 Bell-bottom drilled pier with dowels for a column.

computed bearing stress based on service loads to $0.33f'_c$, where f'_c is the specified concrete compressive strength.

Reinforced-concrete drilled piers can be designed as flexural members with axial load, as indicated in Art. 9.82.

Allowable unfactored loads on drilled piers with various shaft and bell diameters, supported by end bearing on soils of various allowable bearing pressures, are given in Table 9.23. For maximum-size bells (bell diameter 3 times shaft diameter) and a maximum concrete stress $f_{c1} = 0.33f'_c$ for unfactored loads, the required concrete strength, psi, is 19% of the allowable soil pressure, psf.

COLUMNS

Column-design procedures are based on a comprehensive investigation reported by American Concrete Institute Committee 105 ("Reinforced Concrete Column Investigation," *ACI Journal*, February 1933) and followed by many supplemental tests. The results indicated that basically the total capacity for axial load can be predicted,

TABLE 9.23 Allowable Service (Unfactored) Loads on Drilled Piers, kips*

Shaft dia, ft	Shaft area, in ²	$f'_c = 3000$	$f'_c = 4000$	$f'_c = 5000$	$f'_c = 6000$		
1.5	254	251	335	419	503		
2.0	452	447	597	746	895		
2.5	707	700	933	1167	1400		
3.0	1018	1008	1344	1680	2016		
3.5	1385	1371	1828	2285	2742		
4.0	1810	1792	2389	2987	3584		
4.5	2290	2267	3023	3778	4534		
5.0	2827	2799	3732	4665	5597		
5.5	3421	3387	4516	5645	6774		
6.0	4072	4031	5375	6719	8063		
Bell dia, ft	Bell area, ft ²	Safe allowable service-load bearing pressure on soil, psf					
		10,000	12,000	15,000	20,000	25,000	30,000
1.5	1.77	18	21	27	35	44	53
2.0	3.14	31	38	47	63	79	94
2.5	4.91	49	59	74	98	123	147
3.0	7.07	71	85	106	141	177	212
3.5	9.62	96	115	144	192	241	289
4.0	12.57	126	151	188	251	314	377
4.5	15.90	159	191	239	318	398	477
5.0	19.64	196	236	295	393	491	589
5.5	23.76	238	285	356	475	594	713
6.0	28.27	283	339	424	565	707	848
6.5	33.18	332	398	498	664	830	995
7.0	38.48	385	462	577	770	962	1155
7.5	44.18	442	530	663	884	1104	1325
8.0	50.27	503	603	754	1005	1257	1508
8.5	56.74	567	681	851	1135	1418	1702
9.0	63.62	636	763	954	1272	1590	1909
9.5	70.88	709	851	1063	1418	1772	2126
10.0	78.54	785	942	1178	1571	1963	2356
10.5	86.59	866	1039	1299	1732	2165	2598
11.0	95.03	950	1140	1425	1901	2376	2851
11.5	103.87	1039	1246	1558	2077	2597	3116
12.0	113.10	1131	1357	1696	2262	2827	3393

over a wide range of steel and concrete strength combinations and percentages of steel, as the sum of the separate concrete and steel capacities.

9.82 BASIC ASSUMPTIONS FOR STRENGTH DESIGN OF COLUMNS

At maximum capacity, the load on the longitudinal reinforcement of a concentrically loaded concrete column can be taken as the steel area A_{st} times steel yield strength f_y . The load on the concrete can be taken as the concrete area in com-

TABLE 9.23 Allowable Service (Unfactored) Loads on Drilled Piers, kips* (Continued)

Bell dia, ft	Bell area, ft ²	Safe allowable service-load bearing pressure on soil, psf					
		10,000	12,000	15,000	20,000	25,000	30,000
12.5	122.72	1227	1473	1841	2454	3068	3682
13.0	132.73	1327	1593	1991	2655	3318	3982
13.5	143.14	1431	1718	2147	2863	3578	4294
14.0	153.94	1539	1847	2309	3079	3848	4618
14.5	165.13	1651	1982	2477	3303	4128	4954
15.0	176.15	1767	2121	2651	3534	4418	5301
15.5	188.69	1887	2264	2830	3774	4717	5661
16.0	201.06	2011	2413	3016	4021	5027	6032
16.5	213.82	2138	2566	3207	4276	5344	6415
17.0	226.98	2270	2724	3405	4540	5675	6809
17.5	240.53	2405	2886	3608	4811	6013	7216
18.0	254.47	2545	3054	3817	5089	6362	7634

* $f_{c1} = 0.33f'_c$.

NOTE: Bell diameter preferably not to exceed 3 times the shaft diameter. Check shear stress if bell slope is less than 2:1. (Courtesy Concrete Reinforcing Steel Institute.)

pression times 85% of the compressive strength f'_c of the standard test cylinder. The 15% reduction from full strength accounts, in part, for the difference in size and, in part, for the time effect in loading of the column. Capacity of a concentrically loaded column then is the sum of the loads on the concrete and the steel.

The ACI 318 Building Code applies a strength-reduction factor $\phi = 0.75$ for members with spiral reinforcement and $\phi = 0.70$ for other members. For small axial loads ($P_u \leq 0.10f'_cA_g$, where A_g = gross area of column), ϕ may be increased proportionately to as high as 0.90. Capacity of columns with eccentric load or moment may be similarly determined, but with modifications. These modifications introduce the assumptions made for strength design for flexure and axial loads.

The basic assumptions for strength design of columns can be summarized as follows.

1. Strain of steel and concrete is proportional to distance from neutral axis (Fig. 9.50c).
2. Maximum usable compression strain of concrete is 0.003 in/in (Fig. 9.50c).
3. Stress, psi, in longitudinal reinforcing bars equals steel strain ϵ_s times 29,000,000 for strains below yielding, and equals the steel yield strength f_y , tension or compression, for larger strains (Fig. 9.50f).
4. Tensile strength of concrete is negligible.
5. Capacity of the concrete in compression, which is assumed at a maximum stress of $0.85f'_c$, must be consistent with test results. A rectangular stress distribution (Fig. 9.50d) may be used. Depth of the rectangle may be taken as $a = \beta_1c$, where c is the distance from the neutral axis to the extreme compression surface and $\beta_1 = 0.85$ for $f'_c \leq 4000$ psi and 0.05 less for each 1000 psi that f'_c exceeds 4000 psi, but β_1 should not be taken less than 0.65.

In addition to these general assumptions, design must be based on equilibrium and strain compatibility conditions. No essential difference develops in maximum capacity between tied and spiral columns, but spiral-reinforced columns show far

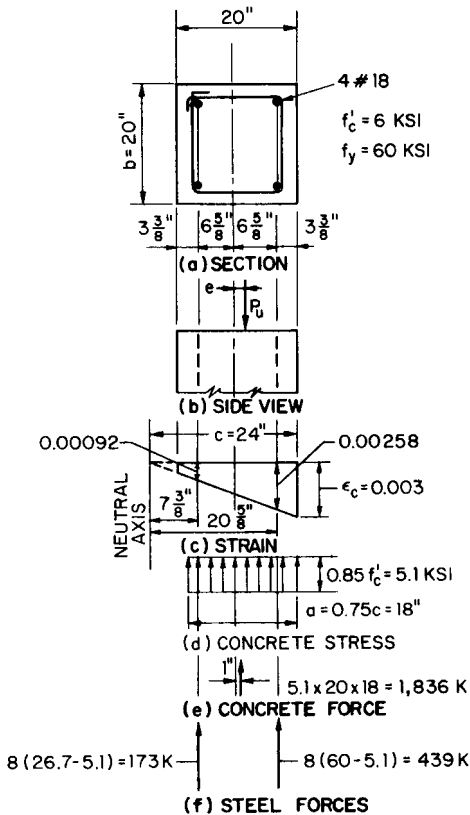

FIGURE 9.50 Stresses and strains in a reinforced-concrete column.

more toughness before failure. Tied-column failures have been relatively brittle and sudden, whereas spiral-reinforced columns that have failed have deformed a great deal and carried a high percentage of maximum load to a more gradual yielding failure. The difference in behavior is reflected in the higher value of ϕ assigned to spiral-reinforced columns.

Additional design considerations are presented in Arts. 9.83 to 9.87. Following is an example of the application of the basic assumptions for strength design of columns.

Example. Determine the capacity of the 20-in-square reinforced-concrete column shown in Fig. 9.50a. The column is reinforced with four No. 18 bars, with $f_y = 60$ ksi, and lateral ties. Area of rebars total 16 in^2 . Concrete strength is $f'_c = 6$ ksi. Assume the factored load P_u to have an eccentricity of 2 in and that slenderness can be ignored.

To begin, assume $c = 24$ in. Then, with $\beta_1 = 0.75$ for $f'_c = 6000$ psi, the depth of the compression rectangle is $a = 0.75 \times 24 = 18$ in. This assumption can be

checked by computing the eccentricity $e = \phi M_n / \phi P_n$, where ϕM_n is the design moment capacity, ft-kips, and ϕP_n is the design axial load strength, kips.

Since the strain diagram is linear and maximum compression strain is 0.003 in/in the strains in the reinforcing steel are found by proportion to be 0.00258 and 0.00092 in/in (Fig. 9.50c). The strain at yield is $60/29,000 = 0.00207 < 0.00258$ in/in. Hence, the stresses in the steel are 60 ksi and $0.00092 \times 29,000 = 26.7$ ksi.

The maximum concrete stress, which is assumed constant over the depth $a = 18$ in, is $0.85f'_c = 0.85 \times 6 = 5.1$ ksi (Fig. 9.50d). Hence, the compression force on the concrete is $5.1 \times 20 \times 18 = 1836$ kips and acts at a distance $20/2 - 18/2 = 1$ in from the centroid of the column (Fig. 9.50e). The compression force on the more heavily loaded pair of reinforcing bars, which have a cross-sectional area of 8 in², is 8×60 less the force on concrete replaced by the steel 8×5.1 , or 439 kips. The compression force on the other pair of bars is $8(26.7 - 5.1) = 173$ kips (Fig. 9.50f). Both pairs of bars act at a distance of $20/2 - 3.375 = 6.625$ in from the centroid of the column.

The design capacity of the column for vertical load is the sum of the nominal steel and concrete capacities multiplied by a strength-reduction factor $\phi = 0.70$.

$$\phi P_n = 0.70(1836 + 173 + 439) = 1714 \text{ kips}$$

The capacity of the column for moment is found by taking moments of the steel and concrete capacities about the centerline of the column.

$$\phi M_n = 0.70 \left[1836 \times \frac{1}{12} + (439 - 173) \frac{6.625}{12} \right] = 209 \text{ ft-kips}$$

The eccentricity for the assumed value of $c = 24$ in is

$$e = \frac{209 \times 12}{1714} = 1.46 < 2 \text{ in}$$

If for a new trial, c is taken as 22.5 in, then $P_u = 1620$ kips, $M_u = 272$ ft-kips, and e checks out close to 2 in. If sufficient load-moment values for other assumed positions of the neutral axis are calculated, a complete load-moment interaction diagram can be constructed (Fig. 9.51).

The nominal maximum axial load capacity P_o of a column without moment equals the sum of the capacities of the steel and the concrete.

$$P_o = 0.85f'_c(A_g - A_{st}) + f_y A_{st} \quad (9.96)$$

where A_g = gross area of column cross section and A_{st} = total area of longitudinal steel reinforcement. For the 20-in-square column in the example:

$$P_o = 0.85 \times 6(400 - 16) + 60 \times 16 = 2918 \text{ kips}$$

The maximum design axial-load strength permitted by the ACI 318 Building Code is

$$\begin{aligned} \phi P_{n(max)} &= 0.80 \phi [0.85f'_c(A_g - A_{st}) + f_y A_{st}] \\ &= 0.80 \times 0.70 [(0.85 \times 6(400 - 16) + 60 \times 16)] = 1634 \text{ kips} \end{aligned} \quad (9.97)$$

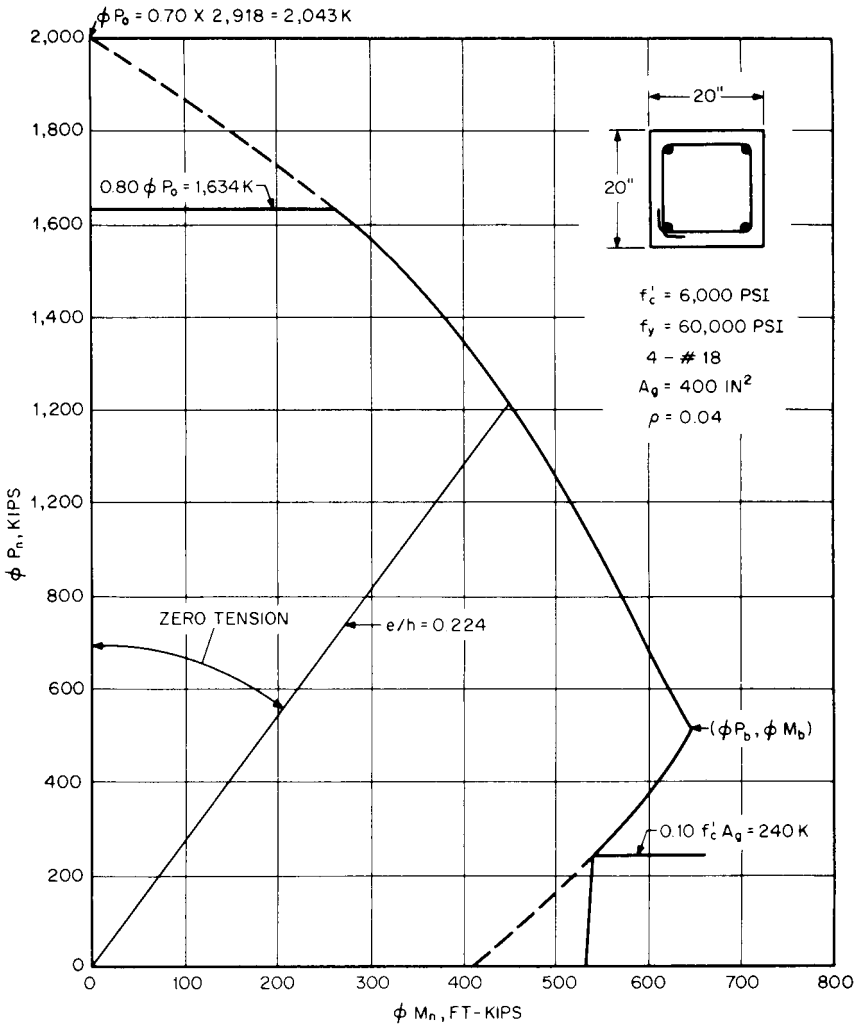

FIGURE 9.51 Load-moment interaction diagram for determination of design strength of a rectangular reinforced-concrete column.

9.83 DESIGN REQUIREMENTS FOR COLUMNS

The ACI 318 Building Code contains the following principal design requirements for columns, in addition to the basic assumptions (Art. 9.82):

1. Columns must be designed for all bending moments associated with a loading condition.

2. For corner columns and other columns loaded unequally on opposite sides in perpendicular directions, biaxial bending moments must be considered.

3. All columns are designed for an eccentricity of the factored load P_u because the maximum design axial load strength cannot be larger than $0.80P_o$ for tied columns, or $0.85P_o$ for spiral columns, where P_o is given by Eq. (9.96).

4. The minimum ratio of longitudinal-bar area to total cross-sectional area of column A_g is 0.01, and the maximum ratio is 0.08. For columns with a larger cross-section than required by loads, however, a smaller A_g , but not less than half the gross area of the columns, may be used for calculating both load capacity and minimum longitudinal bar area. This exception allows reuse of forms for larger-than-necessary columns, and permits longitudinal bar areas as low as 0.005 times the actual column area. At least four longitudinal bars should be used in rectangular reinforcement arrangements, and six in circular arrangements.

5. The ratio of the volume of spiral reinforcement to volume of concrete within the spiral should be at least

$$\rho_s = 0.45 \left(\frac{A_g - A_c}{A_c} \right) \left(\frac{f'_c}{f_y} \right) \tag{9.98}$$

- where A_g = gross cross-sectional area of concrete column, in²
- A_c = area of column within outside diameter of spiral, in²
- f'_c = specified concrete compressive strength, psi
- f_y = specified yield strength of spiral steel, psi (maximum 60,000 psi)

6. For tied columns, minimum size of ties is No. 3 for longitudinal bars that are No. 10 or smaller, and No. 4 for larger longitudinal bars. Minimum vertical spacing of sets of ties is 16 diameters of longitudinal bars, 48 tie-bar diameters, or the least thickness of the column. A set of ties should be composed of one round tie for bars in a circular pattern, or one tie enclosing four corner bars plus additional ties sufficient to provide a corner of a tie at alternate interior bars or at bars spaced more than 6 in from a bar supported by the corner of a tie.

7. Minimum concrete cover required for column reinforcement is listed in Table 9.24.

TABLE 9.24 Minimum Cover, in, for Column Reinforcement*

Type of construction	Reinforcement	Not exposed to weather†	Exposed to weather*
Cast-in-place	Longitudinal	1½	2
	Ties, spirals	1½	1½
Precast	Longitudinal	5/8 ≤ d_b ≤ 1½‡	1½
	Ties, spirals	3/8	1¼
Prestressed	Longitudinal	1½	1½
	Ties, spirals	1	1½

*From ACI 318-99.

†See local code; fire protection may require greater thickness.

‡ d_b = nominal bar diameter, in.

9.84 COLUMN TIES AND TIE PATTERNS

For full utilization, all ties in tied columns must be fully developed (for full tie yield strength) at each corner enclosing a vertical bar or, for circular ties, around the full periphery.

Splices. The ACI 318 Building Code provides arbitrary minimum sizes and maximum spacings for column ties (Art. 9.83). No increases in size nor decrease in the spacings is required for Grade 40 materials. Hence, the minimum design requirements for splices of ties may logically be based on Grade 40 reinforcing steel.

The ordinary closed, square or rectangular, tie is usually spliced by overlapping standard tie hooks around a longitudinal bar. Standard tie patterns require staggering of hook positions at alternate tie spacings, by rotating the ties 90 or 180°. (“Manual of Standard Practice,” Concrete Reinforcing Steel Institute). Two-piece ties are formed by lap splicing or anchoring the ends of U-shaped open ties. Lapped bars should be securely wired together to prevent displacement during concreting.

Tie Arrangements. Commonly used tie patterns are shown in Figs. 9.52 to 9.54. In Fig. 9.53, note the reduction in required ties per set and the improvement in bending resistance about both axes achieved with the alternate bundled-bar arrangements. Bundles may not contain more than four bars, and bar size may not exceed No. 11.

Tie sizes and maximum spacings per set of ties are listed in Table 9.25.

Drawings. Design drawings should show all requirements for splicing longitudinal bars, that is, type of splice, lap length if lapped, location in elevation, and layout in cross section. On detail drawings (placing drawings), dowel erection details should be shown if special large longitudinal bars, bundled bars, staggered splices, or specially grouped bars are to be used.

9.85 BIAXIAL BENDING OF COLUMNS

If column loads cause bending simultaneously about both principal axes of a column cross-section, as for most corner columns, a biaxial bending analysis is required. For rapid preliminary design, Eq. (9.99) gives conservative results

$$\frac{M_x}{M_{ox}} + \frac{M_y}{M_{oy}} \leq 1 \quad (9.99)$$

where M_x, M_y = factored moments about x and y axes, respectively
 M_{ox}, M_{oy} = design capacities about x and y axes, respectively

For square columns with equal longitudinal reinforcement in all faces, $M_{ox} = M_{oy}$, and the relation reduces to:

$$\frac{M_x + M_y}{M_{ox}} \leq 1 \quad (9.100)$$

Because $M_x = e_x P_u$ and $M_y = e_y P_u$, the safe biaxial capacity can be taken from

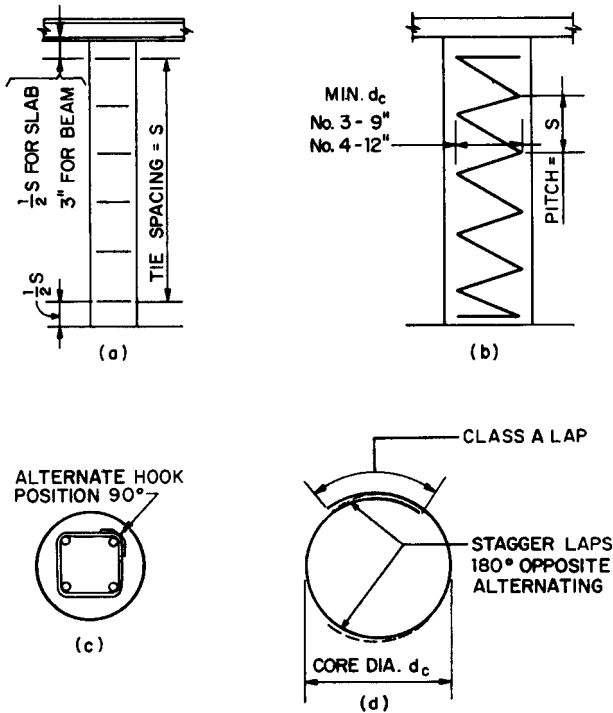

FIGURE 9.52 Circular concrete columns. (a) Tied column. Use ties when core diameter $d_c \leq s$. (b) Spiral-reinforced column, for use when $d_c > s$. (c) Rectangular tie for use in columns with four longitudinal bars. (d) Circular tie.

uniaxial load-capacity tables for the load P_u and the uniaxial bending moment $M_u = (e_x + e_y)P_u$. Similarly, for round columns, the moment capacity is essentially equal in all directions, and the two bending moments about the principal axes may be combined into a single uniaxial factored moment M_u which is then an exact solution

$$M_u = \sqrt{M_x^2 + M_y^2} \tag{9.101}$$

The linear solution always gives a safe design, but becomes somewhat overconservative when the moments M_x and M_y are nearly equal. For these cases, a more exact solution will be more economical for the final design.

9.86 SLENDERNESS EFFECTS ON CONCRETE COLUMNS

The ACI 318 Building Code requires that primary column moments be magnified to provide safety against buckling failure. Detailed procedures, formulas, and design aids are provided in the Code and Commentary.

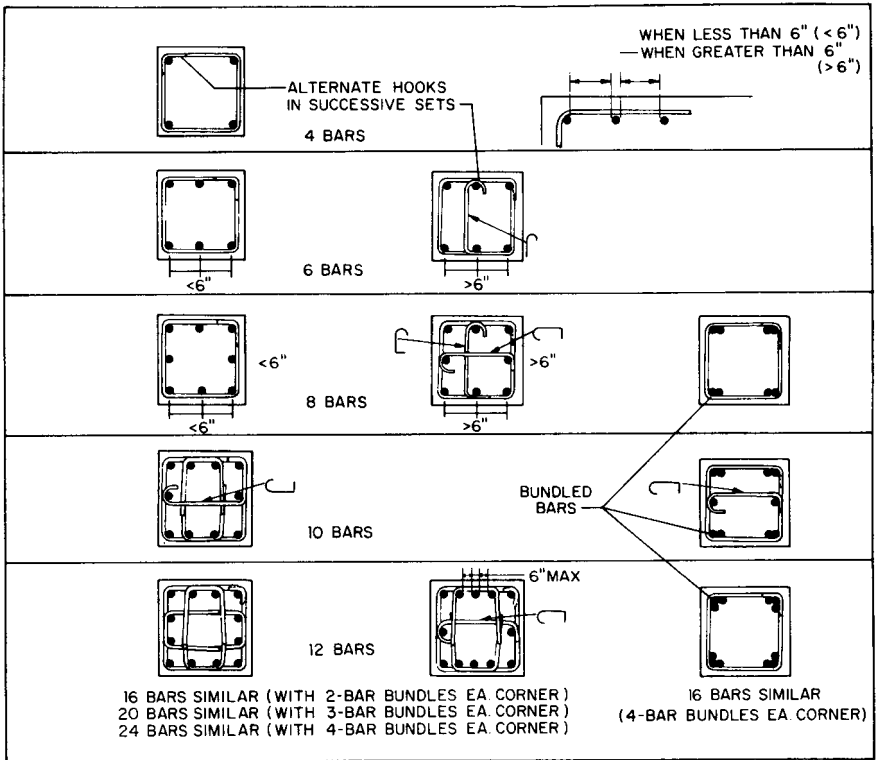

FIGURE 9.53 Ties for square concrete columns. Additional single bars may be placed between any of the tied groups, but clear spaces between bars should not exceed 6 in.

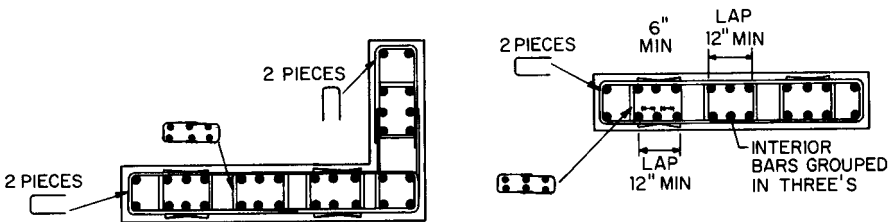

FIGURE 9.54 Ties for wall-like columns. Spaces between corner bars and interior groups of three bars may vary to accommodate average spacing not exceeding 6 in. A single additional bar may be placed in any of such spaces if the average spacing does not exceed 6 in.

TABLE 9.25 Maximum Spacing of Column Ties*

Vertical bar size, number	Size and spacing of ties, in		
	No. 3	No. 4	No. 5
5	10		
6	12		
7	14		
8	16	16	
9	18	18	
10	18	20	
11	†	22	22
14	†	24	27
18	†	24	30

* Maximum spacing not to exceed least column dimensions.

† Not allowed.

For most unbraced frames, an investigation will be required to determine the magnification factor to allow for the effects of sidesway and end rotation. The procedure for determination of the required increase in primary moments, after the determination that slenderness effects cannot be neglected, is complex. For direct solution, the requirements of Sec. 10.10, ACI 318-99 can be met by a $P-\Delta$ analysis. (See, for example, J. G. MacGregor and S. E. Hage, "Stability Analysis and Design of Concrete," *Journal of the Structural Division*, ASCE, Vol. 103, No. ST10, October 1977.)

The direct $P-\Delta$ method of MacGregor and Hage is based upon an equation for a geometric series that was derived for the final second-order deflection as a function of the first-order elastic deflection. This direct $P-\Delta$ analysis provides a very simple method for computing the moment magnifier δ when the stability index Q is greater than 0.04 but equal to or less than 0.22.

$$\delta = 1/(1 - Q) \quad 0.04 < Q \leq 0.22 \quad (9.102)$$

where $Q = P_u \Delta_u / (H_u h_s)$

P_u = sum of the factored loads in a given story

Δ_u = elastically computed first-order lateral deflection due to H_u (neglecting $P-\Delta$ effects) at the top of the story, relative to the bottom

H_u = total factored lateral force (shear) within the story

h_s = height of story, center-to-center of floors or roof

The approximate method of ACI 318-99 may also be used to determine the moment magnifier. This approximate method is a column-by-column correction based upon the stiffness of the column and beams, applied primary design column end moments, and consideration of whether the entire structure is laterally braced against sidesway by definition. (See ACI 318-99, Sec. 10.11).

The ACI 318 Building Code permits slenderness effects to be neglected only for very short, braced columns, with the following limitations for columns with square or rectangular cross-sections:

$L_y \leq 6.6h$ for bending in single curvature

$L_u \leq 10.2h$ for bending in double curvature with unequal end moments

$L_u \leq 13.8h$ for bending in double curvature with equal end moments

and for round columns, five-sixths of the maximum lengths for square columns, where L_u is the unsupported length and h the depth or overall thickness of column in the direction being considered.

These limiting heights are based on the ratio of the total stiffness of the columns to the total stiffnesses of the flexural members, $\Sigma K_c / \Sigma K_B = 50$, at the joint at each end of a column. As these ratios become less, the limiting heights can be increased. When the total stiffnesses of the columns and the floor systems are equal at each end of the column (a common assumption in routine frame analysis), the two ratios = 1.00, and the limiting heights increase about 30%. With this increase, the slenderness effects can be neglected for most columns in frames braced against side-sway.

A frame is considered braced when other structural elements, such as walls, provide stiffness resisting sidesway at least 6 times the sum of the column stiffnesses resisting sidesway in the same direction in the story being considered.

9.87 ECONOMY IN COLUMN DESIGN

Actual costs of reinforced-concrete columns in place per linear foot per kip of load-carrying capacity vary widely. The following recommendations based on relative costs are generally applicable:

Formwork. Use of the same size and shape of column cross-section throughout a floor and, for multistory construction, from footing to roof will permit mass production and reuse for economy. Within usual practicable maximum building heights, about 60 stories or 600 ft, increased speed of construction and saving in formwork will save more than the cost of the excess concrete volume over that for smaller column sizes in upper stories.

Concrete Strength. Use of the maximum concrete compressive strength required to support the factored loads with the minimum allowed reinforcing steel area results in the lowest cost. The minimum size of a multistory column is established by the maximum concrete strength reliably available locally and the limit on maximum area of vertical bars. (Concrete with a compressive strength f'_c of 17,000 psi is commercially available in many areas of the United States.) If the acceptable column size is larger than the minimum possible at the base of the multistory stack, the steel ratio can begin with less than the maximum limit (Art. 9.83). At successive stories above, the steel ratio can be reduced to the minimum, and thereafter, for additional stories, the concrete strength can be reduced. Near the top, as loads reduce further, a further reduction in the steel area to 0.005 times the concrete area may be made (Art. 9.83).

Reinforcing Steel. Comparative cost estimates should be made for combinations of different strengths of concrete and reinforcing bars. For high-rise buildings, using concrete with a high f'_c combined with Grade 75 vertical bars should provide the

greatest economy. Minimum tie requirements can be achieved with four-bar or four-bundle (up to four bars per bundle) arrangements, or by placing an intermediate bar between tied corners not more than 6 in (clear) from the corner bars. For these arrangements, no interior ties are required; only one tie per set is needed. (See Fig. 9.53 and Art. 9.83.) With no interior ties, low-slump concrete can be placed and consolidated more easily, and the cost and time for assembly of column reinforcement cages are greatly reduced. Note that, for small quantities, the local availability of Nos. 14 and 18 bars should be investigated before they are specified.

Details of Column Reinforcement. Where Nos. 14 and 18 bars are used in compression only, end-bearing mechanical splices usually save money. If the splices are staggered 50%, as with two-story lengths, the tensile capacity of the columns will also be adequate for the usual bending moments encountered. For unusually large bending moments, where tensile splices of No. 10 bars and larger are required, mechanical splices are usually least expensive in place. For smaller bar sizes, lap splices, tensile or compressive, are preferred for economy. Some provision for staggered lap splices for No. 8 bars and larger may be required to avoid Class B tension lap splices (Art. 9.49.7).

Where butt splices are used, it will usually be necessary to assemble the column reinforcement cage in place. Two-piece interior ties or single ties with end hooks for two bars (see Art. 9.84) will facilitate this operation.

Where the vertical bar spacing is restricted and lap splices are used, even with the column size unchanged, offset bending of the bars from below may be required. However, where space permits, as with low steel ratios, an additional saving in fabrication and erection time will be achieved by use of straight column verticals offset one bar diameter at alternate floors.

SPECIAL CONSTRUCTION

9.88 DEEP BEAMS

The ACI 318 Building Code defines deep beams as flexural members with clear span-depth ratios less than 2.5 for continuous spans and 1.25 for simple spans. Some types of building components behave as deep beams and require analysis for nonlinear stress distribution in flexure. Some common examples are long, precast panels used as spandrel beams; below-grade walls, with or without openings, distributing column loads to a continuous slab footing or to end walls; and story-height walls used as beams to eliminate lower columns in the first floor area.

Shear. When the clear span-depth ratio is less than 5, beams are classified as deep for shear reinforcement purposes. Separate special requirements for shear apply when span-depth ratio is less than 2 or between 2 and 5. The critical section for shear should be taken at a distance from face of support of $0.15L_n \leq d$ for uniformly loaded deep beams, and of $0.50a \leq d$ for deep beams with concentrated loads, where a is the shear span, or distance from concentrated load to face of support, L_n the clear span, and d the distance from extreme compression surface to centroid of tension reinforcement. Shear reinforcement required at the critical section should be used throughout the span.

The nominal shear strength of the concrete can be taken as

$$V_c = 2 \sqrt{f'_c} b_w d \quad (9.103)$$

where f'_c = specified concrete compressive strength, psi

b_w = width of beam web

d = distance from extreme compression fiber to the centroid of the tension reinforcement

The ACI 318 Building Code also presents a more complicated formula that permits the concrete to carry up to $6 \sqrt{f'_c} b_w d$.

Maximum nominal shear strength when $L_n/d < 2$ should not exceed

$$V_n = V_c + V_s = 8 \sqrt{f'_c} b_w d \quad (9.104)$$

where V_s = nominal shear strength provided by shear reinforcement. When L_n/d is between 2 and 5 maximum nominal shear strength should not exceed

$$V_n = \frac{2}{3} \left(10 + \frac{L_n}{d} \right) \sqrt{f'_c} b_w d \quad (9.105)$$

Required area of shear reinforcement should be determined from

$$f_y d \left[\frac{A_v}{s} \left(\frac{1 + L_n/d}{12} \right) + \frac{A_{vh}}{s_2} \left(\frac{11 - L_n/d}{12} \right) \right] = V_u / \phi - V_c \quad (9.106)$$

where A_v = area of shear reinforcement perpendicular to main reinforcement within a distance s

ϕ = strength-reduction factor = 0.85

s = spacing of shear reinforcement measured parallel to main reinforcement

A_{vh} = area of shear reinforcement parallel to main reinforcement within a distance s_2

s_2 = spacing of shear reinforcement measured perpendicular to main reinforcement

f = yield strength of shear reinforcement

Spacing s should not exceed $d/5$ or 18 in. Spacing s_2 should not exceed $d/3$ or 18 in. The area of shear reinforcement perpendicular to the main reinforcement should be a minimum of

$$A_v = 0.0015 b_w s \quad (9.107)$$

where b_w = width of beam compression face. Area of shear reinforcement parallel to main reinforcement should be at least

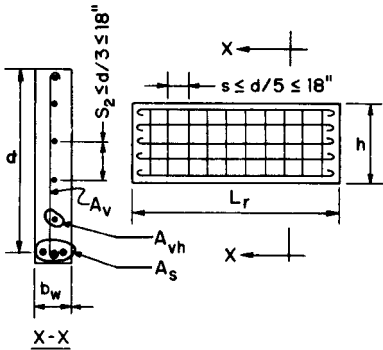

FIGURE 9.55 Reinforcement for deep beams. When the beam thickness exceeds 10 in, a layer of vertical rebar should be provided near each face of the beam.

$$A_{vh} = 0.0025b_w s_2 \quad (9.108)$$

When $b_w > 10$ in. shear reinforcement should be placed in each face of the beam. If the beam has a face exposed to the weather, between one-half and two-thirds of the total shear reinforcement should be placed in the exterior face. Bars should not be smaller than No. 3.

Bending. The area of steel provided for positive bending moment in a deep beam should be at least

$$A_s = \frac{200b_w d}{f_y} \quad (9.109)$$

where f_y = yield strength of flexural reinforcement, psi. This minimum amount can be reduced to one-third more than that required by analysis.

A safe assumption for preliminary design is that the extreme top surface in compression is 0.25 of the overall depth h below the top of very deep beams for computation of a reduced effective depth d for flexure (Fig. 9.55).

(J. G. MacGregor, "Reinforced Concrete Mechanics and Design," 2d ed., Prentice-Hall, Englewood Cliffs, NJ.)

9.89 SHEAR WALLS

Cantilevered shear walls used for bracing structures against lateral displacement (sideway) are a special case of deep beams. They may be used as the only lateral bracing, or in conjunction with beam-column frames. In the latter case, the lateral displacement of the combination can be calculated with the assumption that lateral forces resisted by each element can be distributed to walls and frames in proportion to stiffness. For tall structures, the effect of axial shortening of the frames and the contribution of shear to lateral deformation of the shear wall should not be neglected. Figure 9.56 indicates the forces assumed to be acting on a horizontal cross section of a shear wall.

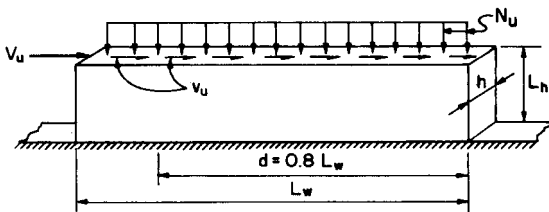

FIGURE 9.56 Shear and normal forces acting on a longitudinal section through a shear wall.

Reinforcement required for flexure of shear walls as a cantilever should be proportioned as for deep beams (Art. 9.88). Shear reinforcement is usually furnished as a combination of horizontal and vertical bars distributed evenly in each story (for increment of load). For low shear (where the factored shear force V_u at a section is less than $0.5\phi V_c$, where V_c is the nominal shear permitted on the concrete), the minimum shear reinforcement required and its location in a wall are the same as for bearing walls (Art. 9.68). Maximum spacing of horizontal shear reinforcement, however, should not exceed $L_w/5$, $3h$, or 18 in, where L_w is the horizontal length of wall and h the overall wall thickness (Fig. 9.56). Maximum spacing of the vertical reinforcement should not exceed $L_w/3$, $3h$, or 18 in.

A thickness of at least $L_w/25$ is advisable for walls with high shear.

The factored horizontal shear force V_u acting on a section through the shear wall must not exceed the nominal shear strength V_n multiplied by $\phi = 0.85$.

$$V_u \leq (\phi V_n = \phi V_c + \phi V_s) \quad (9.110)$$

where V_c = nominal shear strength of the concrete and V_s = nominal shear strength provided by reinforcement. The horizontal shear strength at any section should not be taken larger than

$$V_n = 10 \sqrt{f'_c} hd \quad (9.111)$$

where f'_c = specified concrete compressive strength, psi

d = effective depth of wall, but not to be taken larger than 80% of the wall length

h = wall thickness

Shear carried by the concrete should not exceed the smaller of the values of V_c computed from Eq. (9.112) or (9.113).

$$V_c = 3.3 \sqrt{f'_c} hd + \frac{N_u d}{4L_w} \quad (9.112)$$

where N_u = factored vertical axial load on wall acting with V_u , including tension due to shrinkage and creep (positive for compression, negative for tension).

$$V_c = \left[0.6 \sqrt{f'_c} + \frac{L_w(1.25 \sqrt{f'_c} + 0.2N_u/L_w h)}{M_u/V_u - L_w/2} \right] hd \quad (9.113)$$

where M_u = factored moment at section where V_u acts.

Alternatively, $V_c = 2 \sqrt{f'_c} hd$ may be used if N_u causes compression. Shear strength V_c computed for a section at a height above the base equal to $L_w/2$ or one-half the wall height, whichever is smaller, may be used for all lower sections.

When $V_u > 0.5\phi V_c$, the area of horizontal shear reinforcement within a distance s_2 required for shear is given by

$$A_h = \frac{(V_u/\phi - V_s)s_2}{f_y d} \geq 0.0025hs_2 \quad (9.114)$$

where s_2 = spacing of horizontal reinforcement (max $\leq L_w/5 \leq 3h \leq 18$ in) and f_y = yield strength of the reinforcement.

Also, when $V_u > 0.5\phi V_c$, the area of vertical shear reinforcement with spacing s should be at least

$$A_{vh} = \left[0.0025 + 0.5 \left(2.5 - \frac{L_h}{L_w} \right) \left(\frac{A_h}{nL_h} - 0.0025 \right) \right] hs \geq 0.0025hs \quad (9.115)$$

where L_h is the wall height. But A_{vh} need not be larger than A_h computed from Eq. (9.114). Spacing s should not exceed $L_w/3$, $3h$, or 18 in.

9.90 REINFORCED-CONCRETE ARCHES

Arches are used in roofs for such buildings as hangars, auditoriums, gymnasiums, and rinks, where long spans are desired. An arch is essentially a curved beam with the loads, applied downward in its plane, tending to decrease the curvature. Arches are frequently used as the supports for thin shells that follow the curvature of the arches. Such arches are treated in analysis as two-dimensional, whereas the thin shells behave as three-dimensional elements.

The great advantage of an arch in reinforced concrete construction is that, if the arch is appropriately shaped, the whole cross section can be utilized in compression under the maximum (full) load. In an ordinary reinforced concrete beam, the portion below the neutral axis is assumed to be cracked and does not contribute to the bending strength. A beam can be curved, however, to make its axis follow the lines of thrust very closely for all loading conditions, thus virtually eliminating bending moments.

The component parts of a fixed arch are shown in Fig. 9.57. For a discussion of the different types of arches and the stress analyses required for each, see Art. 5.14.

Because the depth of an arch and loading for maximum moments generally vary along the length, several cross sections must be chosen for design, such as the crown, springing, haunches, and the quarter points. Concrete compressive stresses and shear should be checked at each section, and reinforcement requirements determined. The sections should be designed as rectangular beams or T-beams subjected to bending and axial compression, as indicated in Arts. 9.82 to 9.84.

When an arch is loaded, large horizontal reactions, as well as vertical reactions, are developed at the supports. For roof arches, tie rods may be placed overhead, or in or under the ground floor, to take the horizontal reaction. The horizontal reaction may also be resisted externally by footings on sound rock or piles, by reinforced concrete buttresses, or by adjoining portions of the structure, for example a braced floor or roof at springing level.

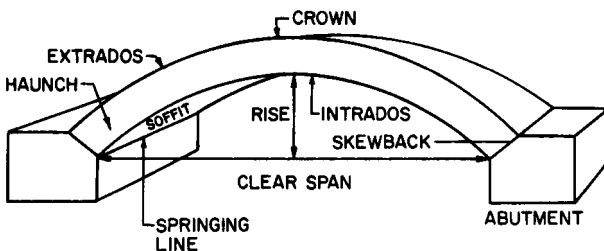

FIGURE 9.57 Components of a fixed arch.

Hinged arches are commonly made of structural steel or precast concrete. The hinges simplify the arch analysis and the connection to the abutment, and they reduce the indeterminate stresses due to shrinkage, temperature, and settlements of supports. For cast-in-place reinforced concrete, hingeless (fixed) arches are often used. They eliminate the cost of special steel hinges needed for hinged concrete arches and permit reduced crown thicknesses, to provide a more attractive shape.

Arches with spans less than 90 ft are usually constructed with ribs 2 to 4 ft wide. Each arch rib is concreted in a continuous operation, usually in 1 day. The concrete may be placed continuously from each abutment toward the crown, to obtain symmetrical loading on the falsework.

For spans of 90 ft or more, however, arch ribs are usually constructed by the alternate block, or *voussoir*, method. Each rib is constructed of blocks of such size that each can be completed in one casting operation. This method reduces the shrinkage stresses. The blocks are cast in such order that the formwork will settle uniformly. If blocks close to the crown section are not placed before blocks at the haunch and the springing sections, the formwork will rise at the crown, and placing of the crown blocks will then be likely to cause cracks in the haunch. The usual procedure is to cast two blocks at the crown, then two at the springing, and alternate until the complete arch is concreted.

In construction by the alternate block method, the block sections are kept separate by timber bulkheads. The bulkheads are kept in place by temporary struts between the *voussoirs*. Keyways left between the *voussoirs* are concreted later. Near piers and abutments where the top slopes exceed about 30° with the horizontal, top forms may be necessary, installed as the casting progresses.

If the arch reinforcement is laid in long lengths, settlement and deformation of the arch formwork can displace the reinforcing steel. Therefore, depending on the curvature and total length, lengths of bars are usually limited to about 30 ft. Splices should be located in the keyways. Lap splices of adjacent bars should be staggered (50% stagger), and located where tension is small.

Upper reinforcement in arch rings may be held in place with spacing boards nailed to props, or with wires attached to transverse timbers supported above the surface of the finished concrete.

Forms for arches may be supported on a timber falsework bent. This bent may consist of joists and beams supported by posts that are braced together and to solid ground. Wedges or other adjustment should be provided at the base of the posts so that the formwork may be adjusted if settlement occurs, and so that the entire formwork may be conveniently lowered after the concrete has hardened sufficiently to take its own load.

(“Guide to Formwork for Concrete,” ACI 347R, American Concrete Institute.)

9.91 REINFORCED-CONCRETE THIN SHELLS

Thin shells are curved slabs with thickness very small compared with the other dimensions. A thin shell possesses three-dimensional load-carrying characteristics. The best natural example of thin-shell behavior is that of an ordinary egg, which may have a ratio of radius of curvature to thickness of 50. Loads are transmitted through thin shells primarily by direct stresses—tension or compression—called membrane stresses, which are almost uniform throughout the thickness. Reinforced-concrete thin-shell structures commonly utilize ratios of radius of curvature to thick-

ness about 5 times that of an eggshell. Because concrete shells are always reinforced, their thickness is usually determined by the minimum thickness required to cover the reinforcement, usually 1 to 4 in. Shells are thickened near the supports to withstand localized bending stresses in such areas. (See also Art. 5.15.)

Shells are most often used as roofs for such buildings as hangars, garages, theaters, and arenas, where large spans are required and the loads are light. The advantages of reinforced-concrete thin shells may be summarized as follows:

- Most efficient use of materials.
 - Great freedom of architectural shapes.
 - Convenient accommodation of openings for natural lighting and ventilation.
 - Ability to carry very large unbalance of forces.
 - High fireproofing value due to lack of corners, thin ribs, and the inherent fire resistance of reinforced concrete.
 - Reserve strength due to many alternative paths for carrying load to the supports.
- One outstanding example withstood artillery fire punctures with only local damage.

Common shapes of reinforced-concrete thin shells used include cylindrical (barrel shells), dome, grained vault, or groinior, elliptical paraboloid, and hyperbolic paraboloid (saddle shape).

Cylindrical shells may be classified as long if the radius of curvature is shorter than the span, or as short (Fig. 9.58). Long cylindrical shells, particularly the continuous, multiple-barrel version which repeats the identical design of each bay (and permits reuse of formwork) in both directions, are advantageous for roofing rectangular-plan structures. Short cylindrical shells are commonly used for hangar roofs with reinforced-concrete arches furnishing support at short intervals in the direction of the span.

Structural analysis of these common styles may be simplified with design aids. ("Design of Cylindrical Concrete Shell Roofs," Manual No. 31, American Society of Civil Engineers; "Design Constants for Interior Cylindrical Concrete Shells," EB020D; "Design Constants for Ribless Concrete Cylindrical Shells," EB028D; "Coefficients for Design of Cylindrical Concrete Shell Roofs" (extension of ASCE Manual No. 31), EB035D; "Design of Barrel Shell Roofs," IS082D, Portland Cement Association; "Concrete Shell Structures—Practice and Commentary," ACI 334.1R, American Concrete Institute.

The ACI 318 Building Code includes specific provisions for thin shells. It allows an elastic analysis as an accepted basis for design and suggests model studies for

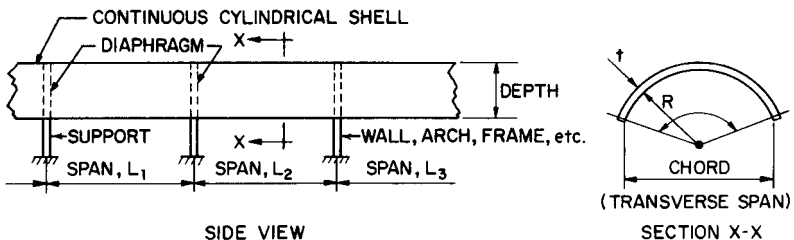

FIGURE 9.58 Continuous cylindrical concrete shell.

complex or unusual shapes, prescribes minimum reinforcement, and prohibits use of the working-stress method for design, thus prescribing selection of all shear and flexural reinforcement by the strength-design method with the same load factors as for design of other elements. Figure 9.59 shows a typical reinforcement arrangement for a long cylindrical shell. (See also F. S. Merritt, "Standard Handbook for Civil Engineers," Sec. 8, "Concrete Design and Construction," and D. P. Billington, "Thin-Shell Concrete Structures," 2d ed., McGraw-Hill Publishing Company, New York.)

9.92 CONCRETE FOLDED PLATES

Reinforced-concrete, folded-plate construction is a versatile concept applicable to a variety of long-span roof construction. Applications using precast, simple V folded plates include segmental construction of domes and (vertically) walls (Fig. 9.60). Inverted folded plates have also been widely used for industrial storage bins. ("Standard Practice for Design and Construction of Concrete Silos and Stacking Tubes for Storing Granular Materials," ACI 313, and "Commentary," ACI 313R, American Concrete Institute.) Determination of stresses in folded-plate construction is described in Art. 5.15.5.

Formwork for folded plates is far simpler than that for curved thin shells. Pre-casting has also been a simpler process to save formwork, permit mass-production construction, and achieve sharp lines for exposed top corners (vees cast upside down) to satisfy aesthetic requirements. For very long spans, posttensioned, draped tendons have been used to reduce the total depth, deflection, and reinforcing-steel

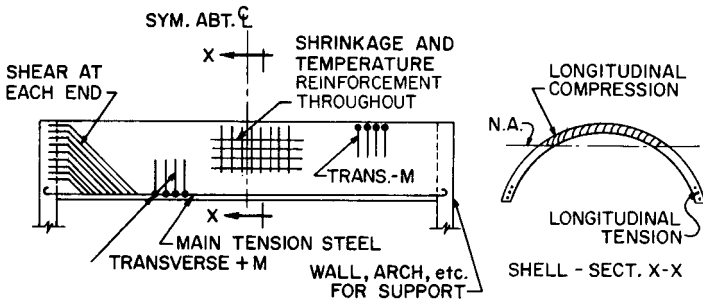

FIGURE 9.59 Reinforcements in a long cylindrical shell. Folded plates are similarly reinforced.

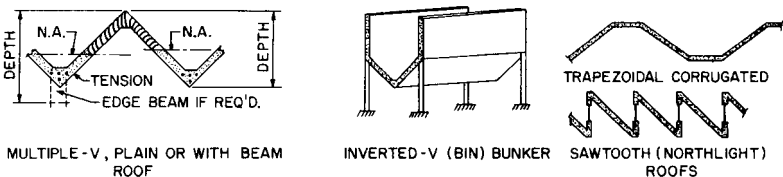

FIGURE 9.60 Typical shapes of concrete folded plates.

requirements. The tendons may be placed in the inclined plates or, more conveniently, in small thickened edge beams. For cast-in-place, folded-plate construction, double forming can usually be avoided if the slopes are less than 35 to 40°.

Since larger transverse bending moments develop in folded plates than in cylindrical shells of about the same proportions, a minimum thickness less than 4 in creates practical problems of placing the reinforcing steel. A number of area in the plates will require three layers of reinforcing steel and, near the intersections of plates, top and bottom bars for transverse bending will be required. Ratios of span to total depth are similar to those for cylindrical shells, commonly ranging from 8 to 15. (See also F. S. Merritt, "Standard Handbook for Civil Engineers," Sec. 8, "Concrete Design and Construction," McGraw-Hill Publishing Company, New York.)

9.93 SLABS ON GRADE

Slabs on ground are often used as floors in buildings. Special use requirements often include heavy-duty floor finish (Art. 9.35) and live-load capacity for heavy concentrated (wheel) load or uniform (storage) loads, or both.

Although slabs on grade seem to be simple structural elements, analysis is extremely complicated. For design load requirements that are unusually heavy and outside common experience, design aids are available. Occasionally, the design will be controlled by wheel loads only, as for floors in hangars, but more frequently by uniform warehouse loadings. ("Design of Slabs on Grade," ACI 360R; American Concrete Institute; "Concrete Floors on Ground," EB075D, Portland Cement Association; "Design of Floors on Ground for Warehouse Loadings," Paul F. Rice, *ACI Journal*, August 1957, paper No. 54-7.)

A full uniform load over an entire area causes no bending moment if the boundaries of the area are simple construction joints. But actual loads in warehouse usage leave unloaded aisles and often alternate panels unloaded. As a result, a common failure of warehouse floors results from *uplift* of the slab off the subgrade, causing negative moment (top) cracking. In lieu of a precise analysis taking into account live-load magnitude, joint interval and detail, the concrete modulus of elasticity, the soil modulus, and load patterns, a quick solution to avoid uplift is to provide a slab sufficiently thick so that its weight is greater than one-fifth the live load. Such a slab may be unreinforced, if properly jointed, or reinforced for temperature and shrinkage stresses only. Alternatively, for very heavy loadings, an analysis and design may be performed for the use of reinforcement, top and bottom, to control uplift moments and cracking. ("Design of Floors on Ground for Warehouse Loadings," Paul F. Rice, *ACI Journal*, Aug., 1957, paper No. 53-7.)

Shrinkage and temperature change in slabs on ground can combine effects adversely to create warping, uplift, and top crackling failures with no load. Closely spaced joint intervals, alternate-panel casting sequence, and controlled curing will avoid these failures. Somewhat longer joint spacings can be specified if reinforcement with an area of about 0.002 times the gross section area of slab is provided in perpendicular directions.

With such reinforcement, warping will usually be negligible if the slab is cast in alternate lanes 12 to 14 ft wide, and provided with contraction joints at 20- to 30-ft spacings in the direction of casting. The joints may be tooled, formed by joint filler inserts, or sawed. One-half the bars or wires crossing the contraction joints

should be cut accurately on the joint line. The warping effect will be aggravated if excess water is used in the concrete and it is forced to migrate in one direction to top or bottom of the slab, for example, when the slab has been cast on a vapor barrier or on a very dry subgrade. For very long slabs, continuous reinforcement, approximately 0.006 times the gross area, is used to eliminate transverse joints in highway and airport pavement. (“Design of Continuously Reinforced Concrete for Highways” and “Construction of Continuously Reinforced Concrete Pavements,” Concrete Reinforcing Steel Institute; and “Suggested Specifications for Heavy-duty Concrete Floor Topping,” IS021B; “Design of Concrete Floors on Ground,” IS046B; “Suggested Specifications for Single-course Floors on Ground,” IS070B, Portland Cement Association.)

9.94 SEISMIC-RESISTANT CONCRETE CONSTRUCTION

The ACI 318 Building Code contains special seismic requirements for design that apply only for areas where the probability of earthquakes capable of causing major damage to structures is high, and where ductility reduction factors for lateral seismic loads are utilized (ACI 319-99, Chap. 21). The general requirements of ACI 318-99 for reinforced concrete provide sufficient seismic resistance for seismic zones (or seismic performance categories) where only minor seismic damage is probable and no reduction factor for ductility is applied to seismic forces. Designation of seismic zones (or seismic performance categories) is prescribed in general building codes, as are lateral force loads for design. (See also Art. 5.18.7.)

Special ductile-frame design is prescribed to resist lateral movements sufficiently to create “plastic” hinges and permit reversal of direction several times. These hinges must form in the beams at the beam-column connections of the ductile.

Shear walls used alone or in combination with ductile beam-column frames must also be designed against brittle (shear) failures under the reversing loads (“Commentary on ACI 318-99”).

Ductility is developed in reinforced concrete by:

Conservative limits on the net flexural tension-steel ratio $\rho \leq 0.025$, to ensure underreinforced behavior. At least two continuous bars must be provided at both top and bottom of flexural members.

Heavy confining reinforcement extending at joints through the region of maximum moment in both columns and beams, to include points where hinges may form. This confining reinforcement may consist of spirals or heavy, closely spaced, well-anchored, closed ties (hoops) with hooked ends engaging the vertical bars or the tie at the far face.

(“ACI Detailing Manual,” SP-66, American Concrete Institute.)

9.95 COMPOSITE FLEXURAL MEMBERS

Reinforced- and prestressed-concrete, composite flexural members are constructed from such components as precast members with cast-in-place flanges, box sections, and folded plates.

Composite structural-steel-concrete members are usually constructed of cast-in-place slabs and structural-steel beams. Interaction between the steel beam and con-

crete slab is obtained by natural bond if the steel beam is fully encased with a minimum of 2 in of concrete on the sides or soffit. If the beam is not encased, the interaction may be accomplished with mechanical anchors (shear connectors). Requirements for composite structural-steel-concrete members are given in the AISC "Specification for Structural Steel for Buildings—Allowable Stress Design and Plastic Design," and AISC "Load and Resistance Factor Design Specification for Structural Steel Buildings," American Institute of Steel Construction.

The design strength of composite flexural members is the same for both shored and unshored construction. Shoring should not be removed, however, until the supported elements have the design properties required to support all loads and limit deflections and cracking. Individual elements should be designed to support all loads prior to the full development of the design strength of the composite member. Premature loading of individual precast elements can cause excessive deflections as the result of creep and shrinkage.

According to the ACI 318 Building Code, the factored horizontal shear force for a composite member may be transferred between individual concrete elements by contact stresses or anchored ties, or both. The factored shear force V_u at the section considered must be equal to or less than the nominal horizontal shear strength V_{nh} multiplied by $\phi = 0.85$.

$$V_u \leq \phi V_{nh} \quad (9.116)$$

When $V_u \leq \phi 80b_v d$, where b_v is the section width and d the distance from the extreme compression surface to the centroid of tension reinforcement, the factored shear force may be transferred by contact stresses without ties, if the contact surfaces are clean, free of laitance and intentionally roughened. Otherwise, if the contact surfaces are clean but not intentionally roughened, fully anchored minimum ties [Eq. (9.81)], spaced not over 24 in or 4 times the least dimension of the supported element are required when $V_u \leq \phi 80b_v d$.

When fully anchored minimum ties are provided and the contact surfaces are clean, free of laitance and intentionally roughened to a full amplitude of about $\frac{1}{4}$ in, the Code permits transferring a factored shear force equal to $\phi(260 + 0.6 \rho_v f_y) \lambda b_v d$ but not more than $\phi(500 b_v d)$, where ρ_v is the ratio of tie reinforcement area to the area of the contact surface, f_y is the yield strength of shear reinforcement, and λ is defined under Eq. (9.117).

When V_u exceeds $\phi(500b_v d)$, the factored shear force may be transferred by shear-friction reinforcement placed perpendicular to assumed cracks. Shear force V_u should not exceed $800A_c$ or $0.2f'_c A_c$, where A_c is the area of the concrete section resisting shear transfer, and f'_c is the specified concrete compressive strength. Required reinforcement area is

$$A_{vf} = \frac{V_u}{\phi f_y \mu} \quad (9.117)$$

where f_y = yield strength of shear reinforcement

μ = coefficient of friction

= 1.4λ for monolithic concrete

= 1.0λ for concrete cast against hardened concrete with surface intentionally roughened to a full amplitude of about 0.25 in

= 0.7λ for concrete anchored by headed studs or rebars to as-rolled structural steel (clean and without paint)

= 0.6λ for concrete cast against hardened concrete not intentionally roughened

- $\lambda = 1.0$ for normal-weight concrete
- $= 0.85$ for sand-lightweight concrete
- $= 0.75$ for all-lightweight concrete

PRECAST-CONCRETE MEMBERS

Precast-concrete members are assembled and fastened together on the jobsite. They may be unreinforced, reinforced, or prestressed. Precasting is especially advantageous when it permits mass production of concrete units. But precasting is also beneficial because it facilitates quality control and use of higher-strength concrete. Form costs may be greatly reduced, because reusable forms can be located on a casting-plant floor or on the ground at a construction site in protected locations and convenient positions, where workmen can move about freely. Many complex thin-shell structures are economical when precast, but would be uneconomical if cast in place.

9.96 DESIGN METHODS FOR PRECAST MEMBERS

Design of precast-concrete members under the ACI 318 Building Code follows the same rules as for cast-in-place concrete. In some cases, however, design may not be governed by service loads, because transportation and erection loads on precast members may exceed the service loads.

Design of joints and connections must provide for transmission of any forces due to shrinkage, creep, temperature, elastic deformation, gravity loads, wind loads, and earthquake motion.

(“Design and Typical Details of Connections for Precast and Prestressed Concrete,” 2d ed., Precast/Prestressed Concrete Institute.)

9.97 REINFORCEMENT COVER IN PRECAST MEMBERS

Less concrete cover is required for reinforcement in precast-concrete members manufactured under plant control conditions than in cast-in-place members because the control for proportioning, placing, and curing is better. Minimum concrete cover for reinforcement required by ACI 318-99 is listed in Table 9.26.

For all sizes of reinforcement in precast-concrete wall panels, minimum cover of $\frac{3}{4}$ in is acceptable at nontreated surfaces exposed to weather and $\frac{3}{8}$ in at interior surfaces.

9.98 TOLERANCES FOR PRECAST CONSTRUCTION

Dimensional tolerances for precast members and tolerances on fitting of precast members vary for type of member, type of joint, and conditions of use. See “PCI

TABLE 9.26 Minimum Reinforcement Cover for Precast Members, in

Concrete exposed to earth or weather:	
Wall panels:	
No. 14 and No. 18 bars	1½
No. 11 bars and smaller	¾
Other members:	
No. 14 and No. 18 bars	2
No. 6 through No. 11 bars	1½
No. 5 bars, ⅝-in wire and smaller	1¼
Concrete not exposed to weather or in contact with the ground:	
Slabs, walls, joists:	
No. 14 and No. 18 bars	1¼
No. 11 bars and smaller	⅝
Beams, girders, columns:	
Principal reinforcement:	
Diameter of bar d_b but not less than ⅝ in and need not be more than 1½ in	
Ties, stirrups or spirals	¾
Shells and folded-plate members:	
No. 6 bars and larger	⅝
No. 5 bars, ⅝-in wire and smaller	¾

Design Handbook,” and “Design and Typical Details of Connections for Precast and Prestressed Concrete,” Precast/Prestressed Concrete Institute; and “Standard Specifications for Tolerances for Concrete Construction and Materials,” ACI 117, American Concrete Institute.

9.99 ACCELERATED CURING

For strength and durability, precast concrete members require adequate curing. They usually are given some type of accelerated curing for economic reuse of forms and casting space. At atmospheric pressure, curing temperatures may be held between 125 and 185°F for 12 to 72 h. Under pressure, autoclave temperatures above 325°F for 5 to 36 h are applied for fast curing. Casting temperatures, however, should not exceed 90°F. See Fig. 9.5.

(“Standard Practice for Curing Concrete,” ACI 308; “Accelerated Curing of Concrete at Atmospheric Pressure—State of the Art,” ACI 517.2R, American Concrete Institute.)

9.100 PRECAST FLOOR AND ROOF SYSTEMS

Long-span, precast-concrete floor and roof units are usually prestressed. Short members, 30 ft or less, are often made with ordinary reinforcement. Types of precast units for floor and roof systems include solid or ribbed slabs, hollow-core slabs, single and double tees, rectangular beams, L-shaped beams, inverted-T-beams, and I-beams.

Hollow-core slabs are usually available in normal-weight or structural light-weight concrete. Units range from 16 to 96 in. in width, and from 4 to 12 in. in

depth. Hollow-core slabs may come with grouted shear keys to distribute loads to adjacent units over a slab width as great as one-half the span.

Manufacturers should be consulted for load and span data on hollow-core slabs, because camber and deflection often control the serviceability of such units, regardless of strength.

(“PCI Design Handbook,” Precast/Prestressed Concrete Institute.)

9.101 PRECAST RIBBED SLABS, FOLDED PLATES, AND SHELLS

Curved shells and folded plates have a thickness that is small compared with their other dimensions. Such structures depend on their geometrical configuration and boundary conditions for strength.

Thickness. With closely spaced ribs or folds, a minimum thickness for plane sections of 1 in is acceptable.

Reinforcement. Welded-wire fabric with a maximum spacing of 2 in may be used for slab portions of thin-section members, and for wide, thin elements 3 in thick or less. Reinforcement should be preassembled into cages, using a template, and placed within a tolerance of +0 in or $-\frac{1}{8}$ in from the nearest face. The minimum clear distance between bars should not be less than $1\frac{1}{2}$ times the nominal maximum size of the aggregate. For minimum concrete cover of reinforcement, see Art. 9.97.

Compressive Strength. Concrete for thin-section, precast-concrete members protected from the weather and moisture and not in contact with the ground should have a compressive strength of at least 4000 psi at 28 days. For elements in other locations, a minimum of 5000 psi is recommended.

Analysis. Determination of axial stresses, moments, and shears in thin sections is usually based on the assumption that the material is ideally elastic, homogeneous, and isotropic.

Forms. Commonly used methods for the manufacture of thin-section, precast-concrete members employ metal or plastic molds, which form the bottom of the slab and the sides of the boundary members. Forms are usually removed pneumatically or hydraulically by admitting air or water under pressure through the bottom form.

(“Architectural Precast Concrete,” Precast/Prestressed Concrete Institute.)

9.102 WALL PANELS

Precast-concrete wall panels include plain panels, decorative panels, natural stone-faced panels, sandwich panels, solid panels, ribbed panels, tilt-up panels, load-bearing and non-load-bearing panels, and thin-section panels. Prestressing, when used with such panels, makes it possible to handle and erect large units and thin sections without cracking.

Forms required to produce the desired size and shape of panel are usually made of steel, wood, concrete, vacuum-formed thermoplastics, fiber-reinforced plastics, or plastics formed into shape by heat and pressure, or any combination of these. For complicated form details, molds of plaster, gelatin, or sculptured sand can be used.

Glossy-smooth concrete finish can be obtained with forms made of plastic. But, for exterior exposure, this finish left untreated undergoes gradual and nonuniform loss of its high reflectivity. Textured surfaces or smooth but nonglossy surfaces obtained by early form removal are preferred for exterior exposure.

Exposed-aggregate monolithic finishes can be obtained with horizontal-cast panels by initially casting a thin layer containing the special surface aggregates in the forms and then casting regular concrete backup. With a thickness of exposed aggregate of less than 1 in, the panel can also be cast face up and the aggregate seeded over the fresh concrete or hand placed in a wet mortar. Variations of exposed surface can be achieved by use of set retardant, acid washes, or sandblasting.

Consolidation of the concrete in the forms to obtain good appearance and durability can be attained by one of the following methods:

External vibration with high-frequency form vibrators or a vibrating table.

Internal or surface vibration with a tamping-type or jitterburg vibrator.

Placing a rich, high-slump concrete in a first layer to obtain uniform distribution of the coarse aggregate and maximum consolidation, and then making the mix for the following layers progressively stiffer. This allows absorption of excessive water from the previous layer.

Tilt-up panels can be economical if the floor slab of the building can be designed for and used as the form for the panels. The floor slab must be level and smoothly troweled. Application of a good bond-breaking agent to the slab before concrete is cast for the panels is essential to obtain a clean lift of the precast panels from the floor slab.

If lifting cables are attached to a panel edge, large bending moments may develop at the center of the wall. For high panels, three-point pickup may be used. To spread pickup stresses, specially designed inserts are cast into the wall at pickup points.

Another method of lifting wall panels employs a vacuum mat—a large steel mat with a rubber gasket at its edges to contact the slab. When the air between mat and panel is pumped out, the mat adheres to the panel, because of the resulting vacuum, and can be used to raise the panel. The method has the advantage of spreading pickup forces over the mat area.

Panels, when erected, must be temporarily braced until other construction is in place to provide required permanent bracing.

(“Tilt-Up Concrete Structures,” ACI 551.R, American Concrete Institute.)

Joints. Joint sealants for panel installations may be mastics or elastomeric materials. These are extensible and can accommodate the movement of panels.

Recommended maximum joint widths and minimum expansions for the common sealants are listed in Table 9.27.

The joint sealant manufacturer should be asked to advise on backup material for use with a sealant and which shape factor should be considered. A good backup material is a rod of sponge material with a minimum compression of 30%, such as foamed polyethylene, polystyrene, polyurethane, polyvinyl chloride, or synthetic rubber.

TABLE 9.27 Maximum Joint Widths for Sealants

Type of Sealant	Maximum joint width, in	Maximum movement, tension, and compression, %
Butyl	$\frac{3}{4}$	± 10
Acrylic	$\frac{3}{4}$	$\pm 15-25$
One-part polyurethane	$\frac{3}{4}$	± 20
Two-part polyurethane	$\frac{3}{4}$	± 25
One-part polysulfide	$\frac{3}{4}$	± 25
Two-part polysulfide	$\frac{3}{4}$	± 25

(“PCI Manual for Structural Design of Architectural Precast Concrete,” Precast/Prestressed Concrete Institute.)

9.103 LIFT SLABS

Lift slabs are precast-concrete floor and roof panels that are cast on a base slab at ground level, one on top of the other, with a bond-breaking membrane between them. Steel collars are embedded in the slabs and fit loosely around the columns. After the slabs have cured, they are lifted to their final position by a patented jack system supported on the columns. The embedded steel collars then are welded to the steel columns to hold the lift slabs in place. This method of construction eliminates practically all formwork.

PRESTRESSED-CONCRETE CONSTRUCTION

Prestressed concrete is concrete in which internal stresses have been introduced during fabrication to counteract the stresses produced by service loads. The prestress compresses the tensile area of the concrete to eliminate or reduce the tensile stresses caused by the loads.

9.104 BASIC PRINCIPLES OF PRESTRESSED CONCRETE

In the application of prestress, the usual procedure is to tension high-strength-steel elements, called tendons, and anchor them to the concrete, which resists the tendency of the stretched steel to shorten after anchorage and is thus compressed. If the tendons are tensioned before concrete has been placed, the prestressing is called **pretensioning**. If the tendons are tensioned after the concrete has been placed the prestressing is called **posttensioning**.

Prestress can prevent cracking by keeping tensile stresses small, or entirely avoiding tension under service loads. The entire concrete cross-section behaves as

an uncracked homogeneous material in bending. In contrast, in nonprestressed, reinforced-concrete construction, tensile stresses are resisted by reinforcing steel, and concrete in tension is considered ineffective. It is particularly advantageous with prestressed concrete to use high-strength concrete.

Loss of Prestress. The final compression force in the concrete is not equal to the initial tension force applied by the tendons. There are immediate losses due to elastic shortening of the concrete, friction losses from curvature of the tendons, and slip at anchorages. There are also long-time losses, such as those due to shrinkage and creep of the concrete, and possibly relaxation of the prestressing steel. These losses should be computed as accurately as possible or determined experimentally. They are deducted from the initial prestressing force to determine the effective prestressing force to be used in design. (The reason that high-strength steels must be used for prestressing is to maintain the sum of these strain losses at a small percentage of the initially applied prestressing strain.) (See also Art. 9.107.)

Stresses. When stresses in prestressed members are determined, prestressing forces can be treated as other external loads. If the prestress is large enough to prevent cracking under design loads, elastic theory can be applied to the entire concrete cross section (Fig. 9.61).

Prestress may be applied to a beam by straight tendons or curved tendons. Stresses at midspan can be the same for both types of tendons, but the net stresses with the curved tendons can remain compressive away from midspan, whereas they become tensile at the top fiber near the ends with straight tendons. For a prestressing force P_s applied to a beam by a straight tendon at a distance e_1 below the neutral axis, the resulting prestress in the extreme surface throughout is

$$f = \frac{P_s}{A_c} \pm \frac{P_s e_1 c}{I_g} \quad (9.118)$$

where P_s/A_c is the compressive stress on a cross section of area A_c , and $P_s e_1 c/I_g$ is the bending stress induced by P_s (positive for compression and negative for tension), as indicated in Fig. 9.61. If stresses $\pm Mc/I_g$ due to moment M caused by external gravity loads are superimposed at midspan, the net stresses in the extreme fibers can become zero at the bottom and compressive at the top. Because the stresses due to gravity loads are zero at the beam ends, the prestress is the final stress there and the top surface of the beam at the ends is in tension.

If the tensile stresses at the ends of beams with straight tendons are excessive, the tendons may be draped, or harped, in a vertical curve. Stresses at midspan will be substantially the same as with straight tendons (if the horizontal component of prestress is nearly equal to P_s) and the stresses at the beam ends will be compressive, because the prestressing force passes through or above the centroid of the end sections (Fig. 9.61). Between midspan and the ends, the cross sections will also be in compression.

9.105 LOSSES IN PRESTRESS

Assumptions in design of total losses in tendon stress of 35,000 psi for pretensioning and 25,000 psi for posttensioning to allow for elastic shortening, frictional losses, slip at anchorages, shrinkage, creep, and relaxation of the prestressing steel

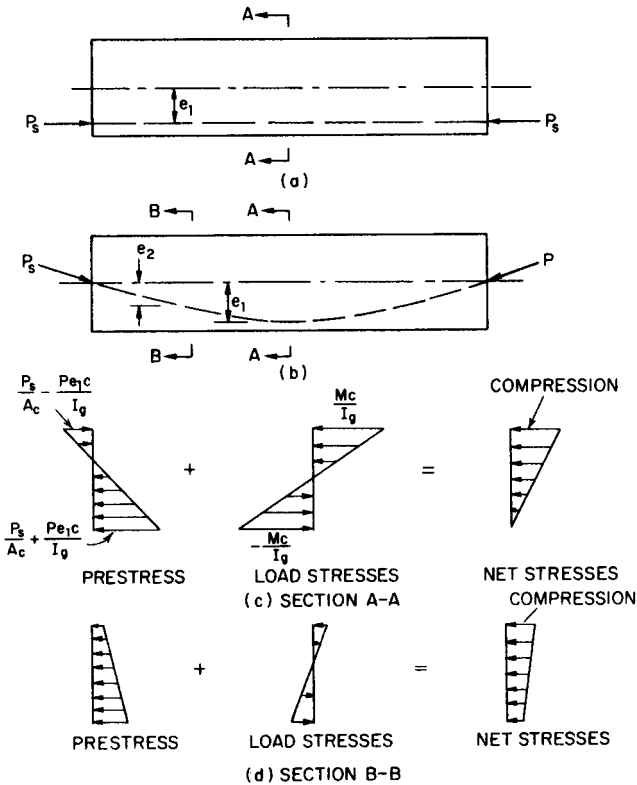

FIGURE 9.61 Prestressed-concrete beam: (a) with straight tendons; (b) with curved tendons; (c) midspan stresses with straight or curved tendons; (d) stresses between midspan and supports with curved tendons. Net stresses near the supports become tensile with straight tendons.

usually gives satisfactory results. Losses greater or smaller than these values have little effect on the design strength but can affect service-load behavior, such as cracking load, deflection, and camber.

Elastic Shortening of Concrete. In pretensioned members, when the tendons are released from fixed abutments and the steel stress is transferred to the concrete by bond, the concrete shortens under the compressive stress. The decrease in unit stress in the tendons equals $P_s E_s / A_c E_c = n f_c$, where E_s is the modulus of elasticity of the steel, psi; E_c the modulus of elasticity of the concrete psi; n the modular ratio, E_s / E_c ; f_c the unit stress in the concrete, psi; P_s the prestressing force applied by the tendons; and A_c the cross-sectional area of the member.

In posttensioned members, the loss due to elastic shortening can be eliminated by using the members as a reaction in tensioning the tendons.

Frictional Losses. In posttensioned members, there may be a loss of prestress where curved tendons rub against their enclosure. The loss may be computed in terms of a curvature-friction coefficient μ . Losses due to unintentional misalignment

may be calculated from a wobble-friction coefficient K (per lin ft). Since the coefficients vary considerably, they should, if possible, be determined experimentally. A safe range of these coefficients for estimates is given in the "Commentary on ACI 318-99," American Concrete Institute.

Frictional losses can be reduced by tensioning the tendons at both ends, or by initial use of a larger jacking force which is then eased off to the required initial force for anchorage.

Slip at Anchorages. For posttensioned members, prestress loss may occur at the anchorages during the anchoring. For example, seating of wedges may permit some shortening of the tendons. If tests of a specific anchorage device indicate a shortening δL , the decrease in unit stress in the prestressing steel is equal to $E_s \delta L / L$, where L is the length of the tendon. This loss can be reduced or eliminated by overtensioning initially by an additional strain equal to the estimated shortening.

Shrinkage of Concrete. Change in length of a member caused by concrete shrinkage results in a prestress loss over a period of time. This change can be determined from tests or experience. Generally, the loss is greater for pretensioned members than for posttensioned members, which are prestressed after much of the shrinkage has occurred. Assuming a shrinkage of 0.0002 in/in of length for a pretensioned member, the loss in tension in the tendons is $0.0002E_s = 0.0002 \times 30 \times 10^6 = 6000$ psi.

Creep of Concrete. Change in length of concrete under sustained load induces a prestress loss proportional to the load over a period of time depending greatly on the aggregate used. This loss may be several times the elastic shortening. An estimate of this loss may be made with an estimated creep coefficient C_{cr} equal to the ratio of additional long-time deformation to initial elastic deformation determined by test. The loss in tension for axial prestress in the steel is, therefore, equal to $C_{cr} n f_c$. Values ranging from 1.5 to 2.0 have been recommended for C_{cr} .

Relaxation of Prestressing Steel. A decrease in stress under constant high strain occurs with some prestressing steels. Steel tensioned to 60% of its ultimate strength may relax and lose as much as 3% of the prestressing force. This type of loss may be reduced by temporary overtensioning, which artificially accelerates relaxation, reducing the loss that will occur later at lower stresses.

(P. Zia et al., "Estimating Prestress Loss," *Concrete International*, June 1979, p. 32, American Concrete Institute; "PCI Design Handbook," Precast/Prestressed Concrete Institute.)

9.106 ALLOWABLE STRESSES AT SERVICE LOADS

At service loads and up to cracking loads, straight-line theory may be used for computing stresses in prestressed beams with the following assumptions:

Strains vary linearly with depth through the entire load range.

At cracked sections, the concrete does not resist tension.

Areas of unbonded open ducts should not be considered in computing section properties.

The transformed area of bonded tendons and non-prestressed reinforcing steel may be included in pretensioned members and, after the tendons have been bonded by grouting, in posttensioned members.

Flexural stresses must be limited to ensure proper behavior at service loads. Limiting these stresses, however, does not ensure adequate design strength.

In establishing permissible flexural stresses, the ACI 318 Building Code recognizes two service-load conditions, that before and that after prestress losses. Higher stresses are permitted for the initial state (temporary stresses) than for loadings applied after the losses have occurred.

Permissible stresses in the concrete for the initial load condition are specified as a percentage of f'_{ci} , the compressive strength of the concrete, psi, at time of initial prestress. This strength is used as a base instead of the usual f'_c , 28-day strength of concrete, because prestress is usually applied only a few days after concrete has been cast. The allowable stresses for prestressed concrete, as given in ACI 318-99, are tabulated in Table 9.28.

Bearing Stresses. Determination of bearing stresses at end regions around post-tensioning anchorages is complicated, because of the elastic and inelastic behavior of the concrete and because the dimensions involved preclude simple analysis under the St. Venant theory of linear stress distribution of concentrated loads. The ACI 318 Building Code formula for bearing stresses [Eq. (9.89)] does not apply to posttensioning anchorages.

Lateral reinforcement may be required in anchorage zones to resist bursting, horizontal splitting, and spalling forces. Expanded design requirements for post-tensioned tendon anchorage zones were introduced into the ACI 318-99 Building Code. The Code's design requirements are compatible with comprehensive provi-

TABLE 9.28 Allowable Stresses for Prestressed Concrete

Concrete:	
Temporary stresses after transfer of prestress but before prestress losses:	
Compression	$0.60f'_{ci}$
Tension in members without auxiliary reinforcement in tension zone, except at ends of simply-supported members	$3\sqrt{f'_{ci}}$ *
Tension at ends of simply-supported members	$6\sqrt{f'_{ci}}$
Service-load stresses after prestress losses:	
Compression for sustained service live load	$0.45f'_c$
Compression for transient or temporary service live load	$0.60f'_c$
Tension in precompressed tensile zone	$6\sqrt{f'_c}$ †
Prestressing steel:	
Due to jacking force	$0.94f_{py}$ ‡
Pretensioning tendons immediately after transfer	$0.82f_{py}$ **
Posttensioning tendons immediately after anchoring	$0.70f_{pu}$

* Where the calculated tension stress exceeds this value, bonded reinforcement should be provided to resist the total tension force on the concrete computed for assumption of an uncracked section.

† May be taken as $12\sqrt{f'_c}$ for members, except two-way slab systems, for which computations based on the transformed cracked section and on bilinear moment-deflection relationships show that immediate and long-term deflection do not exceed the limits given in Table 9.14.

‡ f_{py} = specified yield strength of tendons but not greater than the lesser of 80% of the specified tensile strength f_{pu} and the maximum value recommended by the manufacturer of the tendons or anchorages.

** But not more than $0.74f_{pu}$.

sions adopted previously in the "AASHTO Standard Specifications for Highway Bridges," American Association of State Highway and Transportation Officials.

9.107 DESIGN PROCEDURE FOR PRESTRESSED-CONCRETE BEAMS

Beam design involves choice of shape and dimensions of the concrete member, positioning of the tendons, and selection of amount of prestress.

After a concrete shape and dimensions have been assumed, determine the geometrical properties—cross-sectional area, center of gravity, distances of kern and extreme surface from the centroid, moment of inertia, section moduli, and dead load of the member per unit length.

Treat the prestressing force as a system of external forces acting on the concrete.

Compute bending stresses due to service dead and live loads. From these, determine the magnitude and location of the prestressing force required at sections subject to maximum moment. The prestressing force must result in sufficient compressive stress in the concrete to offset the tensile stresses caused by the bending moments due to dead and live service loads (Fig. 9.61). But at the same time, the prestress must not create allowable stresses that exceed those listed in Table 9.28. Investigation of other sections will guide selection of tendons to be used and determine their position and profile in the beam.

After establishing the tendon profile, prestressing forces, and tendon areas, check stresses at critical points along the beam immediately after transfer, but before losses. Using strength-design methods (Art. 9.108), check the percentage of steel and the strength of the member in flexure and shear.

Design anchorages, if required, and shear reinforcement.

Finally, check the deflection and camber under service loads. The modulus of elasticity of high-strength prestressing steel should not be assumed equal to 29,000,000 psi, as for non-prestressed reinforcement, but should be determined by test or obtained from the manufacturer.

9.108 FLEXURAL-STRENGTH DESIGN OF PRESTRESSED CONCRETE

Flexural design strength should be based on factored loads and the assumptions of the ACI 318 Building Code, as explained in Art. 9.44. The stress f_{ps} in the tendons at factored load ($1.4D + 1.7L$, where D is the dead load and L the live load), however, should not be assumed equal to the specified yield strength. High-strength prestressing steels lack a sharp and distinct yield point, and f_{ps} varies with the ultimate (tensile) strength of the prestressing steel f_{pu} , the prestressing steel percentage ρ_p , and the concrete strength f'_c at 28 days. A stress-strain curve for the prestressing steel being used is necessary for stress and strain compatibility computations of f_{ps} . For unbonded tendons, successive trial-and-error analysis of tendon strain for strength design is straightforward but tedious. Assume a deflection at failure by crushing of the concrete (strain = 0.003 in/in). Determine from the stress-strain curve for the tendon steel the tendon stress corresponding to the total

tendon strain at the assumed deflection. Proceed through successive trials, varying the assumed deflection, until the algebraic sum of the internal tensile and compressive forces equals zero. The moment of the resulting couple comprising the tensile and compressive forces times $\phi = 0.90$ is the design moment strength.

Stress in Bonded Tendons. When such data are not available, and the effective prestress, after losses, f_{se} is at least half the specified ultimate strength f_{pu} of the tendons, the stress f_{ps} in bonded tendons at nominal strength may be obtained from

$$f_{ps} = f_{pu} \left(1 - \frac{\gamma_p R}{\beta_1} \right) \quad (9.119)$$

$$R = \rho_p \frac{f_{pu}}{f'_c} + \frac{df_y}{d_p f'_c} (\rho - \rho') \quad (9.120)$$

where $\gamma_p =$ factor for type of tendon

$$= 0.55 \text{ for } f_{py}/f_{pu} \geq 0.80$$

$$= 0.40 \text{ for } f_{py}/f_{pu} \geq 0.85$$

$$= 0.28 \text{ for } f_{py}/f_{pu} \geq 0.90$$

$$\beta_1 = 0.85 \text{ for } f'_c \leq 4000 \text{ psi; for } f'_c > 4000 \text{ psi, reduce } \beta_1 \text{ by } 0.05 \text{ for each } 1000 \text{ psi that } f'_c \text{ exceeds } 4000 \text{ psi but not to less than } 0.65$$

$$\rho_p = A_{ps}/bd_p$$

A_{ps} = area of tendons in tension zone

b = width of compression face of member

d_p = distance from extreme compression surface to centroid of tendons

$$\rho = A_s/bd$$

d = distance from extreme compression surface to centroid of nonprestressed tension reinforcement

A_s = area of nonprestressed tension reinforcement

$$\rho' = A'_s/bd$$

A'_s = area of compression reinforcement

f_y = specified yield strength of nonprestressed reinforcement

If the area of compression reinforcement is included in the calculation of f_{ps} from Eq. (9.119), R should not exceed 0.17 nor should the distance d' from the extreme compression surface to the centroid of the compression reinforcement exceed $0.15d_p$.

Stress in Unbonded Tendons. When the ratio of span to depth of a prestressed flexural member with unbonded tendons is 35 or less, the stress in the tendons at nominal strength is given by

$$f_{ps} = f_{se} + 10,000 + f'_c/100\rho_p \leq f_{se} + 60,000 \quad (9.121)$$

where f_{se} is the effective stress in the tendons after allowance for prestress losses, but f_{ps} should not exceed the specified yield strength f_{py} of the tendons.

When the ratio of span to depth is larger than 35,

$$f_{ps} = f_{se} + 10,000 + f'_c/300 \rho_p \leq f_{se} + 30,000 \quad (9.122)$$

but f_{ps} should not exceed f_{py} .

Nonprestressed reinforcement conforming to ASTM A615, A706, A185, A496, or A497, when used, in combination with tendons, may be assumed equivalent, at factored moment, to its area times its yield strength, but only if

$$\omega_p \leq 0.36\beta_1 \quad (9.123)$$

$$\omega_p + (d/d_p)(\omega - \omega') \leq 0.36\beta_1 \quad (9.124)$$

$$\omega_{pw} + (d/d_p)(\omega_w - \omega'_w) \leq 0.36\beta_1 \quad (9.125)$$

where $\omega_p = \rho_p f_{ps} / f'_c$
 $\omega = \rho f_y / f'_c$
 $\omega' = \rho' f_y / f'_c$
 $\omega_w, \omega_{pw}, \omega'_w$ = reinforcement indices for flanged sections, computed as for $\omega, \omega_p,$
 and ω' , except that b is the web width, and the reinforcing steel
 area is that required to develop the compressive strength of the web
 only

Design and Cracking Loads. To prevent an abrupt flexural failure by rupture of the prestressing steel immediately after cracking without a warning deflection, the total amount of prestressed and nonprestressed reinforcement should be adequate to develop a factored load in flexure of at least 1.2 times the cracking load, calculated on the basis of a modulus of rupture f_r . For normal-weight concrete, this modulus may be taken as

$$f_r = 7.5 \sqrt{f'_c} \quad (9.126)$$

and for lightweight concrete as

$$f_r = 1.12 f_{ct} \leq 7.5 \sqrt{f'_c} \quad (9.127)$$

where f_{ct} = average splitting tensile strength of lightweight concrete. When the value for f_{ct} is not available, the modulus of rupture of lightweight concrete can be computed for sand-lightweight concrete from

$$f_r = 6.375 \sqrt{f'_c} \quad (9.128)$$

and for all-lightweight concrete from

$$f_r = 5.625 \sqrt{f'_c} \quad (9.129)$$

(“PCI Design Handbook,” Precast/Prestressed Concrete Institute.)

9.109 SHEAR-STRENGTH DESIGN OF PRESTRESSED CONCRETE

The ACI 318 Building Code requires that prestressed concrete beams be designed to resist diagonal tension by strength theory. There are two types of diagonal-tension cracks that can occur in prestressed-concrete flexural members: flexural-shear cracks initiated by flexural-tension cracks, and web-shear cracks caused by principal tensile stresses that exceed the tensile strength of the concrete.

The factored shear force V_u computed from Eq. (9.38) can be used to calculate the diagonal-tension stress. The distance d from the extreme compression surface to the centroid of the tension reinforcement should not be taken less than 0.80 the overall depth h of the beam.

When the beam reaction in the direction of the applied shear introduces compression into the end region of the member, the shear does not need to be checked within a distance $h/2$ from the face of the support.

Minimum Shear Reinforcement. The ACI 318 Building Code requires that a minimum area of shear reinforcement be provided in prestressed-concrete members, except where the factored shear force V_u is less than $0.5\phi V_c$, where ϕV_c is the assumed shear that can be carried by the concrete; or where the depth h of the member is less than 10 in, 2.5 times the thickness of the compression flange, or one-half the thickness of the web; or where tests show that the required nominal (ultimate) flexural and shear capacity can be developed without shear reinforcement.

When shear reinforcement is required, the amount provided perpendicular to the beam axis within a distance s should be not less than A_v given by Eq. (9.81). If, however, the effective prestress force is equal to or greater than 40% of the tensile strength of the flexural reinforcement, a minimum area A_v computed from Eq. (9.130) may be used.

$$A_v = \frac{A_{ps} f_{pu} s}{80 f_y d} \sqrt{\frac{d}{b_w}} \quad (9.130)$$

where A_{ps} = area of tendons in tension zone

f_{pu} = ultimate (tensile) strength of tendons

f_y = yield strength of nonprestressed reinforcement

s = shear reinforcement spacing measured parallel to longitudinal axis of member

d = distance from extreme compression surface to centroid of tension reinforcement

b_w = web width

The ACI 318 Building Code does not permit the yield strength f_y of shear reinforcement to be assumed greater than 60,000 psi except the design yield strength of deformed welded wire fabric should not exceed 80,000 psi. The Code also requires that stirrups be placed perpendicular to the beam axis and spaced not farther apart than 24 in or $0.75h$, where h is the overall depth of the member.

The area of shear reinforcement required to carry the shear in excess of the shear that can be carried by the concrete can be determined from Eq. (9.40a).

Maximum Shear. For prestressed concrete members subjected to an effective prestress force equal to at least 40% of the tensile strength of the flexural reinforcement, the shear strength provided by the concrete is limited to that which would cause significant inclined cracking and, unless Eqs. (9.132) and (9.133) are used, can be taken as equal to the larger of $2\sqrt{f'_c}b_w d$ or

$$V_c = \left(0.60 \sqrt{f'_c} + 700 \frac{V_u d}{M_u} \right) b_w d \leq 5 \sqrt{f'_c} b_w d \quad (9.131)$$

where M_u = factored-load moment at section and V_u = factored shear force at section. The factored moment M_u occurs simultaneously with the shear V_u at the section. The ratio $V_u d/M_u$ should not be taken greater than 1.0.

If the effective prestress force is less than 40% of the tensile strength of the flexural reinforcement, or if a more accurate method is preferred, the value of V_c should be taken as the smaller of the shear forces causing inclined flexure-shear cracking V_{ci} or web-shear V_{cw} , but need not be smaller than $1.7 \sqrt{f'_c} b_w d$.

$$V_{ci} = 0.6 \sqrt{f'_c} b_w d + V_d + V_i M_{cr} / M_{\max} \quad (9.132)$$

$$V_{cw} = (3.5 \sqrt{f'_c} + 0.3 f_{pc}) b_w d + V_p \quad (9.133)$$

where V_d = shear force at section caused by dead load

V_i = shear force at section occurring simultaneously with M_{\max}

M_{\max} = maximum bending moment at the section caused by externally applied factored loads

M_{cr} = cracking moment based on the modulus of rupture (Art. 9.51)

b_w = width of web

f_{pc} = compressive stress in the concrete, after all prestress losses have occurred, at the centroid of the cross section resisting the applied loads, or at the junction of web and flange when the centroid lies within the flange

V_p = vertical component of effective prestress force at section considered

In a pretensioned beam in which the section $h/2$ from the face of the support is closer to the end of the beam than the transfer length of the tendon, the reduced prestress in the concrete at sections falling within the transfer length should be considered when calculating V_{cw} . The prestress may be assumed to vary linearly along the centroidal axis from zero at the beam end to the end of the transfer length. This distance can be assumed to be 50 diameters for strand and 100 diameters for single wire.

(“PCI Design Handbook,” Precast/Prestressed Concrete Institute.)

9.110 BOND, DEVELOPMENT, AND GROUTING OF TENDONS

Three- or seven-wire pretensioning strand should be bonded beyond the critical section for a development length, in, of at least

$$L_d = (f_{ps} - \frac{2}{3} f_{se}) d_b \quad (9.134)$$

where d_p = nominal diameter of strand, in

f_{ps} = stress in tendons at nominal strength, ksi

f_{se} = effective stress in tendons after losses, ksi

(The expression in parentheses is used as a constant without units.) Investigations for bond integrity may be limited to those cross sections nearest each end of the member that are required to develop their full strength under factored load. When bonding does not extend to the end of the member, the bonded development length given by Eq. (9.134) should be doubled.

Minimum Bonded Reinforcement. When prestressing steel is unbonded, the ACI 318 Building Code requires that some bonded reinforcement be placed in the pre-compressed tensile zone of flexural members and distributed uniformly over the tension zone near the extreme tension surface. The amount of bonded reinforcement

that should be furnished for beams, one-way slabs, and two-way slabs, except for two-way flat plates, is

$$A_s = 0.004A \quad (9.135)$$

For two-way flat plates, where tension stress in the concrete under service loads is not greater than $2\sqrt{f'_c}$, bonded reinforcement is not required in positive moment areas. When the tension stress in the concrete under service load exceeds $2\sqrt{f'_c}$, the minimum amount of bonded reinforcement provided in positive moment areas should be

$$A_s = \frac{N_c}{0.5f_y} \quad (9.136)$$

where A = area of that part of the cross section between the flexural tension face and centroid of gross section

N_c = tensile force in the concrete under actual dead load plus live load

f_y = yield strength of bonded reinforcement, but not more than 60,000 psi

In the negative moment regions of two-way flat plates at column supports, the minimum amount of bonded reinforcement provided in the top of the slab in each direction should be

$$A_s = 0.00075A_{cf} \quad (9.137)$$

where A_{cf} = larger gross cross-sectional area of the slab-beam strips of the two orthogonal equivalent frames intersecting at a column of a two-way flat plate

The Code requires the bonded reinforcement computed by Eq. (9.137) to be distributed between lines that are $1.5h$ outside opposite faces of the column support, and that at least four bars be provided in each direction spaced not over 12 in, where h is the depth of the flat plate. Requirements are included in the Code for minimum lengths and extensions of the bonded reinforcement computed by Eqs. (9.135), (9.136) and (9.137).

Grouting of Tendons. When posttensioned tendons are to be bonded, a cement grout is usually injected under pressure (80 to 100 psi) into the space between the tendon and the sheathing material of the duct. The grout can be inserted in holes in the anchorage heads and cones, or through buried pipes. To ensure filling of the space, the grout can be injected under pressure at one end of the member until it is forced out the other end. For long members, it can be injected at each end until it is forced out a vent between the ends.

Grout provides bond between the posttensioning tendons and the concrete member and protects the tendons against corrosion.

Members should be above 35°F in temperature at the time of grouting. This minimum temperature should be maintained until field-cured 2-in cubes of grout reach a minimum compressive strength of 800 psi.

Tendon Sheaths. Ducts for grouted or unbonded tendons should be mortar-tight and nonreactive with concrete, tendons, or filler material. To facilitate injection of the grout, the duct should be at least $\frac{1}{4}$ in larger than the diameter of a single posttensioning tendon. For multiple strand, bar or wire tendons, the duct should have an internal area at least twice the gross area of the prestressing steel.

9.111 APPLICATION AND MEASUREMENT OF PRESTRESS

The actual amount of prestressing force applied to a concrete member should be determined by measuring the tendon elongation, also by checking jack pressure on a calibrated gage or load cell, or by use of a calibrated dynamometer. If the discrepancy in force determination exceeds 5%, it should be investigated and corrected. Elongation measurements should be correlated with average load-elongation curves for the particular prestressing steel being used.

9.112 CONCRETE COVER IN PRESTRESSED MEMBERS

The minimum thicknesses of cover required by the ACI 318 Building Code for prestressed and nonprestressed reinforcement, ducts, and end fittings in prestressed concrete members are listed in Table 9.29.

The cover for nonprestressed reinforcement in prestressed concrete members under plant control may be that required for precast members (Table 9.26). When the general code requires fire-protection covering greater than that required by the ACI 318 Building Code, such cover should be used.

(“PCI Design Handbook,” Precast/Prestressed Concrete Institute.)

TABLE 9.29 Minimum Concrete Cover in in Prestressed Members

Concrete cast against and permanently exposed to earth	3
Concrete exposed to earth or weather:	
Wall panels, slabs, and joists	1
Other members	1½
Concrete not exposed to weather or in contact with the ground:	
Slabs, walls, joists	¾
Beams, girders, columns:	
Principal reinforcement	1½
Ties, stirrups, or spirals	1
Shells and folded-plate members:	
Reinforcement ⅝ in. and smaller	⅜
Other reinforcement	d_b but not less than ¾ in.