

---

# SECTION THREE

---

## PROTECTION AGAINST HAZARDS

---

**David W. Mock\***

*Gee & Jenson*

*West Palm Beach, Florida*

A hazard poses the threat that an unwanted event, possibly a catastrophe, may occur. Risk is the probability that the event will occur. Inasmuch as all buildings are subject to hazards such as hurricanes, earthquakes, flood, fire, and lightning strikes, both during and after construction, building designers and contractors have the responsibility of estimating the risks of these hazards and the magnitudes of the consequences should the events be realized.

### **3.1 RISK MANAGEMENT**

---

After the risk of a hazard has been assessed, the building designers and contractors, guided by building-code, design standards, zoning-code, and health-agency specifications and exercising their best judgment, should decide on an acceptable level for the risk. With this done, they should then select a cost-effective way of avoiding the hazard, if possible, or protecting against it so as to reduce the risk of the hazard's occurring to within the acceptable level.

Studies of building failures provide information that building designers should use to prevent similar catastrophes. Many of the lessons learned from failures have led to establishment of safety rules in building codes. These rules, however, generally are minimum requirements and apply to ordinary structures. Building designers, therefore, should use judgment in applying code requirements and should adopt more stringent design criteria where conditions dictate.

Such conditions are especially likely to exist for buildings in extreme climates or in areas exposed to natural hazards, such as high winds, earthquakes, floods, landslides, and lightning. Stricter criteria should also be used for buildings that are

---

\*Revised and updated from Sec. 3, "Protection Against Hazards" by the late Frederick S. Merritt, Consulting Engineer.

tall and narrow, are low but very large, have irregular or unusual shapes, house hazardous material or critical functions, or are of novel construction. Furthermore, building codes may not contain provisions for some hazards against which building designers nevertheless should provide protection. Examples of such hazards are vandalism, trespass, and burglary. In addition, designers should anticipate conditions that may exist in buildings in emergencies and provide refuge for occupants or safe evacuation routes.

Building designers also should use judgment in determining the degree of protection to be provided against specific hazards. Costs of protection should be commensurate with probable losses from an incident. In many cases, for example, it is uneconomical to construct a building that will be immune to extreme earthquakes, high winds of tornadoes, arson, bombs, burst dams, or professional burglars. Full protection, however, should always be provided against hazards with a high probability of occurrence accompanied by personal injuries or high property losses. Such hazards include hurricanes and gales, fire, and vandals.

Structures containing extremely valuable contents or critical equipment justifying design for even the most extreme events may require special hardened rooms or areas.

### 3.1.1 Design Life of Buildings

For natural phenomena, design criteria may be based on the probability of occurrence of extreme conditions, as determined from statistical studies of events in specific localities. These probabilities are often expressed as mean recurrence intervals.

A **mean recurrence interval** of an extreme condition is the average time, in years, between occurrences of a condition equal to or worse than the specified extreme condition. For example, the mean recurrence interval of a wind of 60 mi/hr or more may be recorded for Los Angeles as 50 years. Thus, after a building has been erected in Los Angeles, chances are that in the next 50 years it will be subjected only once to a wind of 60 mi/hr or more. Consequently, if the building was assumed to have a 50-year life, designers might logically design it basically for a 60-mi/hr wind, with a safety factor included in the design to protect against low-probability faster winds. Mean recurrence intervals are the basis for minimum design loads for high winds, snowfall, and earthquake in many building codes.

### 3.1.2 Safety Factors

Design of buildings for both normal and emergency conditions should always incorporate a safety factor against failure. The magnitude of the safety factor should be selected in accordance with the importance of a building, the extent of personal injury or property loss that may result if a failure occurs, and the degree of uncertainty as to the magnitude or nature of loads and the properties and behavior of building components.

As usually incorporated in building codes, a safety factor for quantifiable system variables is a number greater than unity. The factor may be applied in either of two ways.

One way is to relate the maximum permissible load, or demand, on a system under service conditions to design capacity. This system property is calculated by

dividing by the safety factor the ultimate capacity, or capacity at failure, for sustaining that type of load. For example, suppose a structural member assigned a safety factor of 2 can carry 1000 lb before failure occurs. The service load then is  $1000/2 = 500$  lb.

The second way in which codes apply safety factors is to relate the ultimate capacity of a system, to a design load. This load is calculated by multiplying the maximum load under service conditions by a safety factor, often referred to as a **load factor**. For example, suppose a structural member assigned a load factor of 2 is required to carry a service load of 500 lb. Then, the member should be designed to have a capacity for sustaining a design load of  $500 \times 2 = 1000$  lb, without failing.

While both methods achieve the objective of providing reserve capacity against unexpected conditions, use of load factors offers the advantage of greater flexibility in design of a system for a combination of different loadings, because a different load factor can be assigned to each type of loading in accordance with probability of occurrence and effects of other uncertainties.

Safety factors for various building systems are discussed in following sections of the book. This section presents general design principles for protection of buildings and occupants against high winds, earthquakes, water, fire, lightning, and intruders.

## 3.2 WIND PROTECTION

---

For practical design, wind and earthquakes may be treated as horizontal, or lateral, loads. Although wind and seismic loads may have vertical components, these generally are small and readily resisted by columns and bearing walls. Vertical earthquake components can be important in the design of connections as in precast concrete structures. Wind often generates significant uplift forces that require special attention to vertical restraint and lateral support for members in reverse bending.

The variation with height of the magnitude of a wind load for a multistory building differs from that of a seismic load. Nevertheless, provisions for resisting either type of load are similar.

In areas where the probability of either a strong earthquake or a high wind is small, it is nevertheless advisable to provide in buildings considerable resistance to both types of load. In many cases, such resistance can be incorporated with little or no increase in costs over designs that ignore either high wind or seismic resistance.

### 3.2.1 Wind Characteristics

Because wind loads are considered horizontal forces, wind pressure, for design purposes, should be assumed to be applied to the gross area of the vertical projection of that portion of the building above the average level of the adjoining ground. Although the loads are assumed to be horizontal, they may nevertheless apply either inward pressures or suction to inclined and horizontal surfaces. In any case, wind loads should be considered to act normal to the exposed building surfaces. Furthermore, wind should be considered to be likely to come from any direction unless

it is known for a specific locality that extreme winds may come only from one direction. As a consequence of this assumption, each wall of a rectangular building should be considered in design to be subject to the maximum wind load.

Winds generally strike a building in gusts. Consequently, the building is subjected to dynamic loading. Nevertheless, except for unusually tall or narrow buildings, it is common practice to treat wind as a static loading, even though wind pressures are not constant. High velocity winds can cause considerable vibrations, particularly in lighter more flexible structures. Therefore, connections that tend to loosen under heavy vibration should be avoided.

Estimation of design wind pressures is complicated by several factors. One factor is the effect of natural and man-made obstructions along the ground. Another factor is the variation of wind velocity with height above ground. Still another factor complicating wind-pressure calculation is the effect of building or building component shape or geometry (relationship of height or width to length) on pressures. For important buildings, it is advisable to base design wind pressures on the results of wind tunnel tests of a model of a building, neighboring buildings, and nearby terrain.

### 3.2.2 Wind Pressures and Suctions

Pressures are considered positive when they tend to push a building component toward the building interior. They are treated as negative for suctions or uplifts, which tend to pull components outward.

Figure 3.1*a* illustrates wind flow over the sloping roof of a low building. For roofs with inclines up to about 30°, the wind may create an uplift over the entire roof (Fig. 3.1*b*). Also, as shown in Fig. 3.1*b* and *c*, the pressure on the external face of the windward wall is positive and on the leeward wall, negative (suction). If there are openings in the walls, the wind will impose internal pressures on the walls, floors, and roof. The net pressure on any building component, therefore, is the vector sum of the pressures acting on opposite faces of the component.

Because of the wind characteristics described in Art. 3.2.1 and the dependence of wind pressures on building geometry, considerable uncertainty exists as to the magnitude, direction, and duration of the maximum wind loads that may be imposed on any portion of a specific building. Consequently, numerous assumptions, based to some extent on statistical evidence, generally are made to determine design wind loads for buildings. Minimum requirements for wind loads are presented in local and model building codes.

Codes usually permit design wind loads to be determined either by mathematical calculations in accordance with an analytical procedure specified in the code or by wind-tunnel tests. Such tests are advisable for structures with unusual shapes, unusual response to lateral loading, or location where channeling effects or buffeting in the wake of upwind obstructions are likely to occur. Tests also are desirable where wind records are not available or when more accurate information is needed. Codes often require that the following conditions be met in execution of wind-tunnel tests:

1. Air motion should be modeled to account for variation of wind speed with elevation and the intensity of the longitudinal component of turbulence.
2. The geometric scale of the model should not be greater than 3 times that of the longitudinal component of turbulence.

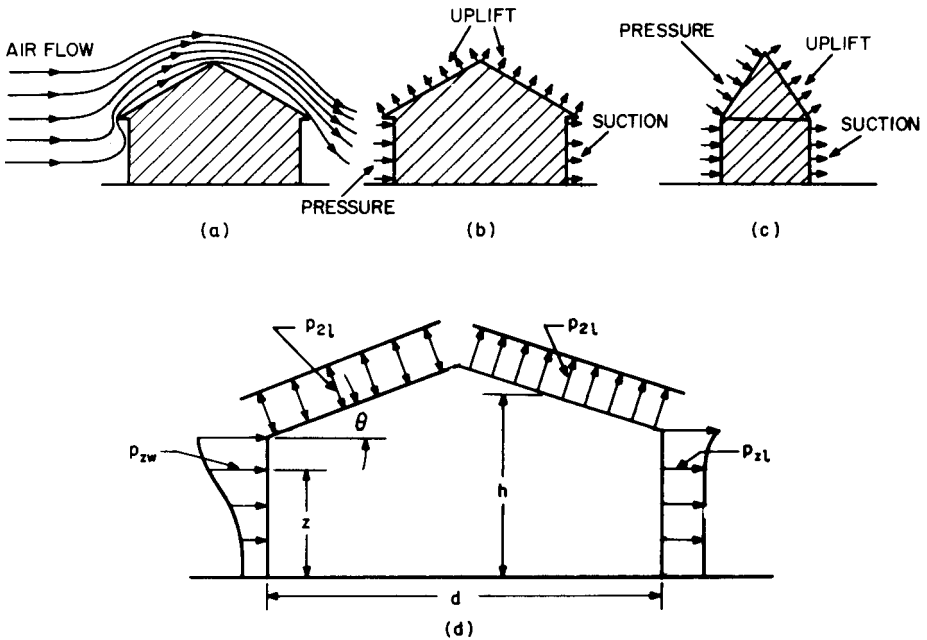

**FIGURE 3.1** Effects of wind on a low building with pitched roof. (a) Airflow at the building. (b) Wind applies inward pressure against the windward wall, suction on the leeward wall, and uplift over all of a roof with slight slopes. (c) With a steep roof, inward pressure acts on the windward side of the roof and uplift only on the leeward side. (d) Pressure distribution along walls and roof assumed for design of wind bracing of a building.

3. Instruments used should have response characteristics consistent with the required accuracy of measurements to be recorded.
4. Account should be taken of the dependence of forces and pressures on the Reynolds number of the air motion.
5. Tests for determining the dynamic response of a structure should be conducted on a model scaled with respect to dimensions, mass distribution, stiffness, and damping of the proposed structure.

In the analytical methods specified by building codes, maximum wind speeds observed in a region are converted to velocity pressures. These are then multiplied by various factors, to take into account building, site, and wind characteristics, to obtain design static wind loads. Bear in mind, however, that, in general, code requirements are applicable to pressures considerably smaller than those created by tornadoes, which may have wind speeds up to 600 mi/hr. For more information on wind loads, see Art. 5.1.2.

### 3.2.3 Failure Modes

Consideration of the ways in which winds may damage or destroy buildings suggests provisions that should be made to prevent failures. Past experience with build-

ing damage by winds indicates buildings are likely to fail by overturning; sliding; separation of components; excessive sway, or drift; or structural collapse. Lightweight and open-sided structures may be subject to failure either partially, or wholly, due to uplift.

Subjected to lateral forces  $W$ , and uplift  $U$ , a building may act as a rigid body and overturn. It would tend to rotate about the edge of its base on the leeward side (Fig. 3.2a). Overturning is resisted by the weight of the building  $M$  with a lever arm  $e$  measured from the axis of rotation. Building codes usually require that

$$Me \geq 1.5Wh \quad (3.1)$$

where  $Wh$  is the overturning moment.

Resistance to overturning may be increased by securely anchoring buildings to foundations. When this is done, the weight of earth atop the footings and pressing against foundation walls may be included with the weight of the building.

In addition to the danger of overturning, there is the risk of a building being pushed laterally by high winds. Sliding is resisted by friction at the base of the footings and earth pressure against foundation walls (Fig. 3.2b). (Consideration should be given to the possibility that soil that is highly resistant to building movement when dry may become weak when wet.) Another danger is that a building may be pushed by wind off the foundations (Fig. 3.2c). Consequently, to prevent this, a building should be firmly anchored to its foundations.

Buildings also may be damaged by separation of other components from each other. Therefore, it is essential that all connections between structural members and between other components and their supports be capable of resisting design wind loads. The possibility of separation of components by uplift or suction should not be overlooked. Such pressures can slide a roof laterally or lift it from its supports, tear roof coverings, rip off architectural projections, and suck out windows. Failure of a roof diaphragm or bracing can result in failure of the entire structure.

Another hazard is drift (sway) or collapse without overturning or sliding. Excessive drift when the wind rocks a building can cause occupant discomfort, induce failure of structural components by fatigue, or lead to complete collapse of the structure. The main resistance to drift usually is provided by structural components, such as beams, columns, bracing, and walls that are also assigned the task of supporting gravity loads. Some means must be provided to transmit wind or seismic loads from these members to the foundations and thence to the ground. Otherwise, the building may topple like a house of cards (Fig. 3.2d).

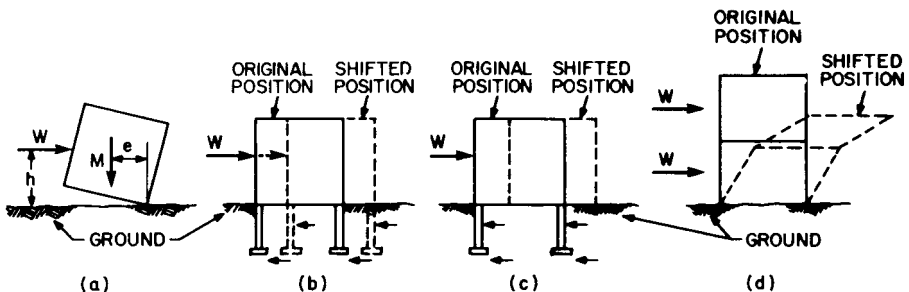

**FIGURE 3.2** Some ways in which wind may destroy a building: (a) overturning; (b) sliding through the ground; (c) sliding off the foundations; (d) excessive drift (sidesway).

Consideration should also be given to the potential for wind blown debris impacting a structure and damaging critical lateral force resisting elements.

### 3.2.4 Limitation of Drift

There are no generally accepted criteria for maximum permissible lateral deflections of buildings. Some building codes limit drift of any story of a building to a maximum of 0.25% of the story height for wind and 0.50% of the story height for earthquake loads. Drift of buildings of unreinforced masonry may be restricted to half of the preceding values. The severer limitation of drift caused by wind loads is applied principally because they are likely to occur more frequently than earthquakes and will produce motions that will last much longer.

Three basic methods are commonly used, separately or in combination with each other, to prevent collapse of buildings under lateral loads, limit drift and transmit the loads to the foundations. These methods are illustrated in Fig. 3.3. One method is to incorporate shear walls in a building. A shear wall is a vertical cantilever with high resistance to horizontal loads parallel to its length (Fig. 3.3a). A pair of perpendicular walls can resist wind from any direction, because any wind load can be resolved into components in the planes of the walls (Fig. 3.3b). Diaphragms developed from wall, floor, and roof sheathing can function similar to solid shear walls when properly attached and laterally supported.

A second method of providing resistance to lateral loads is to incorporate diagonal structural members to carry lateral forces to the ground (Fig. 3.3c). (The diagonals in Fig. 3.3c are called X bracing. Other types of bracing are illustrated in Fig. 3.6.) Under lateral loads, the braced bays of a building act like cantilever vertical trusses. The arrows in Fig. 3.3c show the paths taken by wind forces from points of application to the ground. Note that the lateral loads impose downward axial forces on the leeward columns, causing compression, and uplift on the windward columns, causing tension.

A third method of providing resistance to lateral loads is to integrate the beams, or girders, and columns into rigid frames (Fig. 3.3d). In a rigid frame, connections between horizontal and vertical components prevent any change of angle between the members under loads. (Drift can occur only if beams and columns bend.) Such joints are often referred to as rigid, moment, or wind connections. They prevent the frame from collapsing in the manner shown in Fig. 3.2d until the loads are so

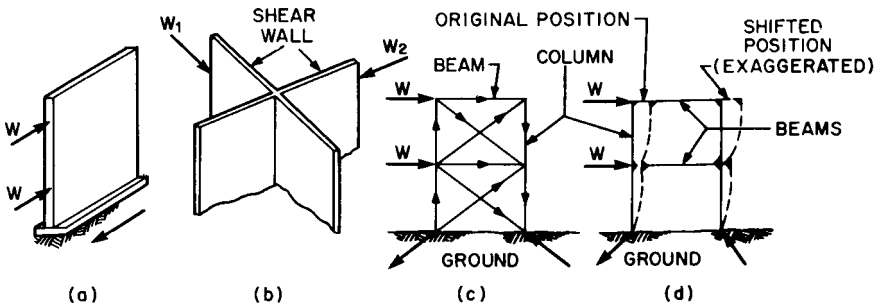

**FIGURE 3.3** Some ways of restricting drift of a building: (a) shear wall; (b) pair of perpendicular shear walls; (c) diagonal bracing; (d) rigid frames.

large that the strength of the members and connections is exhausted. Note that in a rigid frame, leeward columns are subjected to bending and axial compression and windward columns are subjected to bending and axial tension.

In addition to using one or more of the preceding methods, designers can reduce drift by proper shaping of buildings, arrangements of structural components, and selection of members with adequate dimensions and geometry to withstand changes in dimensions. Shape is important because low, squat buildings have less sidesway than tall, narrow buildings, and buildings with circular or square floor plans have less sidesway than narrow rectangular buildings with the same floor area per story.

**Low Buildings.** Figure 3.4*a* illustrates the application of diagonal bracing to a low, industrial-type building. Bracing in the plane of the roof acts with the rafters, ridge beam, and an edge roof beam as an inclined truss, which resists wind pressures on the roof. Each truss transmits the wind load to the ends of the building. Diagonals in the end walls transmit the load to the foundations. Wind pressure on the end walls is resisted by diagonal bracing in the end panels of the longitudinal walls. Wind pressure on the longitudinal walls, like wind on the roof, is transmitted to the end walls.

For large buildings, rigid frames are both structurally efficient and economic.

Alternatively, for multistory buildings, shear walls may be used. Figure 3.4*b* shows shear walls arranged in the shape of a T in plan, to resist wind from any direction. Figure 3.4*c* illustrates the use of walls enclosing stairwells and elevator shafts as shear walls. In apartment buildings, closet enclosures also can serve as shear walls if designed for the purpose. Figure 3.4*d* shows shear walls placed at the ends of a building to resist wind on its longitudinal walls. Wind on the shear walls, in turn, is resisted by girders and columns in the longitudinal direction acting as rigid frames. (See also Art. 5.12.)

**Tall Buildings.** For low buildings, structural members sized for gravity loads may require little or no enlargement to also carry stresses due to lateral loads. For tall buildings, however, structural members often have to be larger than sizes necessary only for gravity loads. With increase in height, structural material requirements increase rapidly. Therefore, for tall buildings, designers should select wind-bracing systems with high structural efficiency to keep material requirements to a minimum.

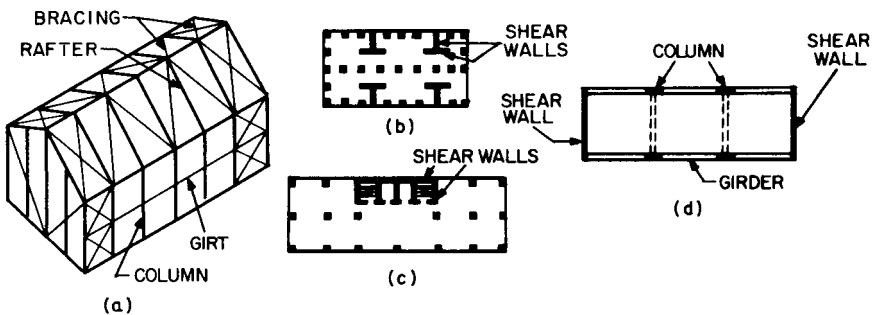

**FIGURE 3.4** Bracing of low buildings: (a) diagonal bracing in roofs and walls; (b) isolated pairs of shear walls in a T pattern; (c) service-core enclosure used as shear walls; (d) shear walls at ends of building and rigid frames in the perpendicular direction.



While shear walls, diagonal bracing, and rigid frames can be used even for very tall buildings, simple framing arrangements, such as planar systems, are not so efficient in high structures as more sophisticated framing. For example, shear walls or rigid frames in planes parallel to the lateral forces (Fig. 3.5*a*) may sway considerably at the top if the building is tall (more than 30 stories) and slender. Resistance to drift may be improved, however, if the shear walls are arranged in the form of a tube within the building (Fig. 3.5*b*). (The space within the tube can be utilized for stairs, elevators, and other services. This space is often referred to as the **service core**.) The cantilevered tube is much more efficient in resisting lateral forces than a series of planar, parallel shear walls containing the same amount of material. Similarly, rigid frames and diagonal bracing may be arranged in the form of an internal tube to improve resistance to lateral forces.

The larger the size of the cantilevered tube for a given height, the greater will be its resistance to drift. For maximum efficiency of a simple tube, it can be arranged to enclose the entire building (Fig. 3.5*c*). For the purpose, bracing or a rigid frame may be erected behind or in the exterior wall, or the exterior wall itself may be designed to act as a perforated tube. Floors act as horizontal diaphragms to brace the tube and distribute the lateral forces to it.

For very tall buildings, when greater strength and drift resistance are needed than can be provided by a simple tube, the tube around the exterior may be augmented by an internal tube (Fig. 3.5*d*) or by other arrangements of interior bracing, such as shear walls attached and perpendicular to the exterior tube. As an alternative, a very tall building may be composed of several interconnected small tubes, which act together in resisting lateral forces (Fig. 3.5*e*). Known as bundled tubes, this type of framing offers greater flexibility in floor-area reduction at various levels than a tube-within-a-tube type, because the tubes in a bundle can differ in height.

Diagonal bracing is more efficient in resisting drift than the other methods, because the structural members carry the loads to the foundations as axial forces, as shown in Fig. 3.3*c*, rather than as a combination of bending, shear, and axial

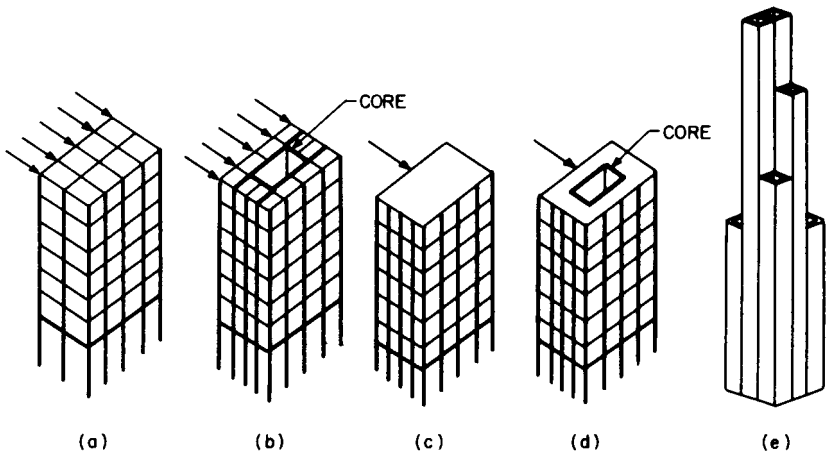

**FIGURE 3.5** Bracing of tall buildings: (a) diagonal bracing, rigid frames, or shear walls placed in planes (bents) parallel to the lateral forces; (b) interior tube enclosing service core; (c) perforated tube enclosing the building; (d) tube within a tube; (e) bundled tubes.

forces. Generally, the bracing is arranged to form trusses composed of triangular configurations, because of the stability of such arrangements. The joints between members comprising a triangle cannot move relative to each other unless the length of the members changes. Figure 3.6*a* illustrates the use of X bracing in the center bay of a multistory building to form a vertical cantilever truss to resist lateral forces.

Other forms of bracing, however, may be used as an alternative to reduce material requirements or to provide more space for wall penetrations, such as doors and windows. Figure 3.6*b* shows how a single diagonal can be used in the center bay to form a vertical truss. In large bays, however, the length of the diagonal may become too long for structural efficiency. Hence, two or more diagonals may be inserted in the bay instead, as shown in Fig. 3.6*c* to *e*. The type of bracing in Fig. 3.6*c* is known as K bracing; that in Fig. 3.6*d*, as V bracing; and that in Fig. 3.6*e*, as inverted V bracing. The V type, however, has the disadvantage of restricting deflection of the beams to which the diagonals are attached and thus compelling the diagonals to carry gravity loads applied to the beams.

The bracing shown in Fig. 3.6*a* to *e* has the disadvantage of obstructing the bay and interfering with placement of walls, doors, passageways, and, for bracing along the building exterior, placement of windows. Accordingly, the inverted V type often is converted to knee bracing, short diagonals placed near beam-to-column joints. When knee bracing also is architecturally objectionable because of interference with room arrangements, an alternative form of wind bracing, such as rigid frames or shear walls, has to be adopted.

Trusses also can be placed horizontally to stiffen buildings for less drift. For example, Fig. 3.6*f* shows a building with wind bracing provided basically by an internal vertical cantilever tube. A set of horizontal trusses at the roof and a similar set at an intermediate level tie the tube to the exterior columns. The trusses reduce the drift at the top of the building by utilizing bending resistance of the columns. A belt of horizontal trusses around the building exterior at the roof and the intermediate level also helps resist drift of the building by utilizing bending resistance of the exterior columns.

When not considered architecturally objectionable, diagonal bracing may be placed on the building exterior to form a braced tube. The bracing may also serve

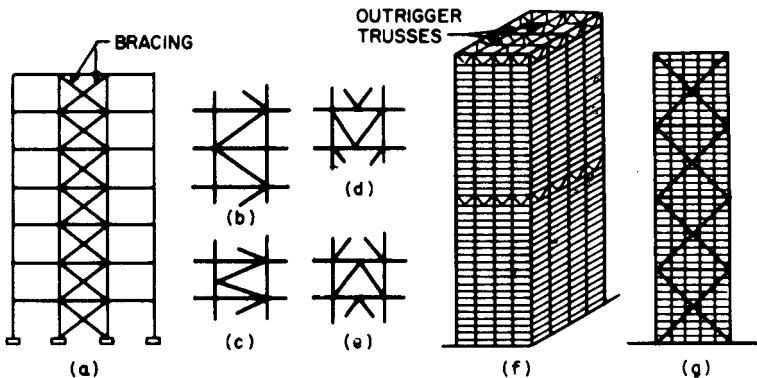

**FIGURE 3.6** Some types of diagonal bracing: (a) X bracing in an interior bay; (b) single diagonal; (c) K bracing; (d) V bracing; (e) inverted V bracing; (f) horizontal trusses at the roof and intermediate levels to restrict drift; (g) X bracing on the exterior of a building.

as columns to transmit floor and roof loads to the ground. Figure 3.6g shows how multistory X bracing has been used to create a braced tube for a skyscraper.

See also Arts. 3.3.5, 5.18–19, and Secs. 7 through 10.

(Council on Tall Buildings and Urban Habitat, “Planning and Design of Tall Buildings,” Vols. SC, SB, and CB, American Society of Civil Engineers, New York; E. Simiu and R. H. Scanlon, “Wind Effects on Structures,” John Wiley & Sons, Inc., New York; Minimum Design Loads for Tall Buildings and Other Structures ANSI/ASCE 7-98, American Society of Civil Engineers, New York.)

### 3.3 PROTECTION AGAINST EARTHQUAKES

---

Buildings should be designed to withstand minor earthquakes without damage, because they may occur almost everywhere. For major earthquakes, it may not be economical to prevent all damage but collapse should be precluded.

Because an earthquake and a high wind are not likely to occur simultaneously, building codes usually do not require that buildings be designed for a combination of large seismic and wind loads. Thus, designers may assume that the full strength of wind bracing is also available to resist drift caused by earthquakes.

The methods of protecting against high winds described in Art. 3.2.4 may also be used for protecting against earthquakes. Shaking of buildings produced by temblors, however, is likely to be much severer than that caused by winds. Consequently, additional precautions must be taken to protect against earthquakes. Because such protective measures will also be useful in resisting unexpectedly high winds, such as those from tornadoes, however, it is advisable to apply aseismic design principles to all buildings.

These principles require that collapse be avoided, oscillations of buildings damped, and damage to both structural and nonstructural components minimized. Nonstructural components are especially liable to damage from large drift. For example, walls are likely to be stiffer than structural framing and therefore subject to greater seismic forces. The walls, as a result, may crack or collapse. Also, they may interfere with planned actions of structural components and cause additional damage. Consequently, aseismic design of buildings should make allowance for large drift, for example, by providing gaps between adjoining buildings and between adjoining building components not required to be rigidly connected together and by permitting sliding of such components. Thus, partitions and windows should be free to move in their frames so that no damage will occur when an earthquake wracks the frames. Heavy elements in buildings, such as water tanks, should be firmly anchored to prevent them from damaging critical structural components. Displacement of gas hot water heaters is a common cause of gas fires following earthquakes.

#### 3.3.1 Earthquake Characteristics

Earthquakes are produced by sudden release of tremendous amounts of energy within the earth by a sudden movement at a point called the **hypocenter**. (The point on the surface of the earth directly above the hypocenter is called the **epicenter**.) The resulting shock sends out longitudinal, vertical, and transverse vibrations in all

directions, both through the earth's crust and along the surface, and at different velocities. Consequently, the shock waves arrive at distant points at different times.

As a result, the first sign of the advent of an earthquake at a distant point is likely to be faint surface vibration of short duration as the first longitudinal waves arrive at the point. Then, severe shocks of longer duration occur there, as other waves arrive.

Movement at any point of the earth's surface during a temblor may be recorded with seismographs and plotted as seismograms, which show the variation with time of displacements. Seismograms of past earthquakes indicate that seismic wave forms are very complex.

Ground accelerations are also very important, because they are related to the inertial forces that act on building components during an earthquake. Accelerations are recorded in accelerograms, which are a plot of the variation with time of components of the ground accelerations. Newton's law relates acceleration to force:

$$F = Ma = \frac{W}{g} a \quad (3.2)$$

where  $F$  = force, lb

$M$  = mass accelerated

$a$  = acceleration of the mass, ft/s<sup>2</sup>

$W$  = weight of building component accelerated, lb

$g$  = acceleration due to gravity = 32.2 ft/s<sup>2</sup>

### 3.3.2 Seismic Scales

For study of the behavior of buildings in past earthquakes and application of the information collected to contemporary aseismic design, it is useful to have some quantitative means for comparing earthquake severity. Two scales, the Modified Mercalli and the Richter, are commonly used in the United States.

The Modified Mercalli scale compares earthquake intensity by assigning values to human perceptions of the severity of oscillations and extent of damage to buildings. The scale has 12 divisions. The severer the reported oscillations and damage, the higher is the number assigned to the earthquake intensity (Table 3.1).

The Richter scale assigns numbers  $M$  to earthquake intensity in accordance with the amount of energy released, as measured by the maximum amplitude of ground motion:

$$M = \log A - 1.73 \log \frac{100}{D} \quad (3.3)$$

where  $M$  = earthquake magnitude 100 km from epicenter

$A$  = maximum amplitude of ground motion, micrometers

$D$  = distance, km, from epicenter to point where  $A$  is measured

The larger the ground displacement at a given location, the higher the value of the number assigned on the Richter scale. A Richter magnitude of 8 corresponds approximately to a Modified Mercalli intensity of XI, and for smaller intensities, Richter scale digits are about one unit less than corresponding Mercalli Roman numerals.

**TABLE 3.1** Modified Mercalli Intensity Scale (Abridged)

Intensity	Definition
I	Detected only by sensitive instruments.
II	Felt by a few persons at rest, especially on upper floors. Delicate suspended objects may swing.
III	Felt noticeably indoors; not always recognized as an earthquake. Standing automobiles rock slightly. Vibration similar to that caused by a passing truck.
IV	Felt indoors by many, outdoors by few; at night some awaken. Windows, dishes, doors rattle. Standing automobiles rock noticeably.
V	Felt by nearly everyone. Some breakage of plaster, windows, and dishes. Tall objects disturbed.
VI	Felt by all; many frightened and run outdoors. Falling plaster and damaged chimneys.
VII	Everyone runs outdoors. Damage of buildings negligible to slight, depending on quality of construction. Noticeable to drivers of automobiles.
VIII	Damage slight to considerable in substantial buildings, great in poorly constructed structures. Walls thrown out of frames; walls, chimneys, monuments fall; sand and mud ejected.
IX	Considerable damage to well-designed structures; structures shifted off foundations; buildings thrown out of plumb; underground pipes damaged. Ground cracked conspicuously.
X	Many masonry and frame structures destroyed; rails bent; water splashed over banks; landslides; ground cracked.
XI	Bridges destroyed; rails bent greatly; most masonry structures destroyed; underground service pipes out of commission; landslides; broad fissures in ground.
XII	Total damage. Waves seen in surface level; lines of sight and level distorted; objects thrown into air.

### 3.3.3 Effects of Ground Conditions

The amplitude of ground motion at a specific location during an earthquake depends not only on distance from the epicenter but also on the types of soil at the location. (Some soils suffer a loss of strength in an earthquake and allow large, uneven foundation settlements, which cause severe property damage.) Ground motion usually is much larger in alluvial soils (sands or clays deposited by flowing water) than in rocky areas or diluvial soils (material deposited by glaciers). Reclaimed land or earth fills generally undergo even greater displacements than alluvial soils. Consequently, in selection of sites for structures in zones where severe earthquakes are highly probable during the life of the structures, preference should be given to sites with hard ground or rock to considerable depth, with sand and gravel as a less desirable alternative and clay as a poor choice.

### 3.3.4 Seismic Forces

During an earthquake, the ground may move horizontally in any direction and up and down, shifting the building foundations correspondingly. Inertial forces, or seis-

mic loads, on the building resist the displacements. Major damage usually is caused by the horizontal components of these loads, inasmuch as vertical structural members and connections generally have adequate strength to resist the vertical components. Hence, as for wind loads, buildings should be designed to resist the maximum probable horizontal component applied in any direction. Vertical components of force must be considered in design of connections in high mass prefabricated elements such as precast concrete slabs and girders.

Seismic forces vary rapidly with time. Therefore, they impose a dynamic loading on buildings. Calculation of the building responses to such loading is complex (Art. 5.18.6) and is usually carried out only for important buildings that are very tall and slender. For other types of buildings, building codes generally permit use of an alternative static loading for which structural analysis is much simpler (Art. 5.19).

### 3.3.5 Aseismic Design

The basic methods for providing wind resistance—shear walls, diagonal bracing, and rigid frames (Art. 3.2.4) are also suitable for resisting seismic loads. Ductile rigid frames, however, are preferred because of large energy-absorbing capacity. Building codes encourage their use by permitting them to be designed for smaller seismic loads than those required for shear walls and diagonal bracing. (Ductility is a property that enables a structural member to undergo considerable deformation without failing. The more a member deforms, the more energy it can absorb and therefore the greater is the resistance it can offer to dynamic loads.)

For tall, slender buildings, use of the basic methods alone in limiting drift to an acceptable level may not be cost-effective. In such cases, improved response to the dynamic loads may be improved by installation of heavy masses near the roof, with their movements restricted by damping devices. Another alternative is installation of energy-absorbing devices at key points in the structural framing, such as at the bearings of bottom columns or the intersections of cross bracing.

Designers usually utilize floors and roofs, acting as horizontal diaphragms, to transmit lateral forces to the resisting structural members. Horizontal bracing, however, may be used instead. Where openings occur in floors and roofs, for example for floors and elevators, structural framing should be provided around the openings to bypass the lateral forces.

As for wind loads, the weight of the building and of earth adjoining foundations are the only forces available to prevent the horizontal loads from overturning the building. [See Eq. (3.1) in Art. 3.2.3.] Also, as for wind loads, the roof should be firmly anchored to the superstructure framing, which, in turn, should be securely attached to the foundations. Furthermore, individual footings, especially pile and caisson footings, should be tied to each other to prevent relative movement.

Building codes often limit the drift per story under the equivalent static seismic load (see Art. 5.19.3). Connections and intersections of curtain walls and partitions with each other or with the structural framing should allow for a relative movement of at least twice the calculated drift in each story. Such allowances for displacement may be larger than those normally required for dimensional changes caused by temperature variations.

See also Art. 5.19.

(N. M. Newmark and E. Rosenblueth, "Fundamentals of Earthquake Engineering," and J. S. Stratta, "Manual of Seismic Design," Prentice-Hall, Englewood Cliffs, N.J.; "Standard Building Code," Southern Building Code Congress International, Inc., 900 Montclair Road, Birmingham, AL 35213-1206; "Uniform Build-

ing Code,” International Conference of Building Officials, Inc., 5360 South Workman Mill Road, Whittier, CA 90601.)

### **3.4 PROTECTION AGAINST WATER**

---

Whether thrust against and into a building by a flood, driven into the interior by a heavy rain, leaking from plumbing, storm surge, or seeping through the exterior enclosure, water can cause costly damage to a building. Consequently, designers should protect buildings and their contents against water damage.

Protective measures may be divided into two classes: floodproofing and waterproofing. Floodproofing provides protection against flowing surface water, commonly caused by a river overflowing its banks. Waterproofing provides protection against penetration through the exterior enclosure of buildings of groundwater, rainwater, and melting snow. Buildings adjacent to large water bodies may also require protection from undermining due to erosion and impact from storm driven waves.

#### **3.4.1 Floodproofing**

A flood occurs when a river rises above an elevation, called flood stage, and is not prevented by enclosures from causing damage beyond its banks. Buildings constructed in a flood plain, an area that can be inundated by a flood, should be protected against a flood with a mean recurrence interval of 100 years. Maps showing flood-hazard areas in the United States can be obtained from the Federal Insurance Administrator, Department of Housing and Urban Development, who administers the National Flood Insurance Program. Minimum criteria for floodproofing are given in National Flood Insurance Rules and Regulations (*Federal Register*, vol. 41, no. 207, Oct. 26, 1976).

Major objectives of floodproofing are to protect fully building and contents from damage from a 100-year flood, reduce losses from more devastating floods, and lower flood insurance premiums. Floodproofing, however, would be unnecessary if buildings were not constructed in flood prone areas. Building in flood prone areas should be avoided unless the risk to life is acceptable and construction there can be economically and socially justified.

Some sites in flood prone areas possess some ground high enough to avoid flood damage. If such sites must be used, buildings should be clustered on the high areas. Where such areas are not available, it may be feasible to build up an earth fill, with embankments protected against erosion by water, to raise structures above flood levels. Preferably, such structures should not have basements, because they would require costly protection against water pressure.

An alternative to elevating a building on fill is raising it on stilts (columns in an unenclosed space). In that case, utilities and other services should be protected against damage from flood flows. The space at ground level between the stilts may be used for parking automobiles, if the risk of water damage to them is acceptable or if they will be removed before flood waters reach the site.

Buildings that cannot be elevated above flood stage should be furnished with an impervious exterior. Windows should be above flood stage, and doors should seal tightly against their frames. Doors and other openings may also be protected with a flood shield, such as a wall. Openings in the wall for access to the building may

be protected with a movable flood shield, which for normal conditions can be stored out of sight and then positioned in the wall opening when a flood is imminent.

To prevent water damage to essential services for buildings in flood plains, important mechanical and electrical equipment should be located above flood level. Also, auxiliary electric generators to provide some emergency power are desirable. In addition, pumps should be installed to eject water that leaks into the building. Furthermore, unless a building is to be evacuated in case of flood, an emergency water supply should be stored in a tank above flood level, and sewerage should be provided with cutoff valves to prevent backflow.

### 3.4.2 Waterproofing\*

In addition to protecting buildings against floods, designers also should adopt measures that prevent groundwater, rainwater, snow, or melted snow from penetrating into the interior through the exterior enclosure. Water may leak through cracks, expansion joints or other openings in walls and roofs, or through cracks around windows and doors. Also, water may seep through solid but porous exterior materials, such as masonry. Leakage generally may be prevented by use of weatherstripping around windows and doors, impervious waterstops in joints, or caulking of cracks and other openings. Methods of preventing seepage, however, depend on the types of materials used in the exterior enclosure.

#### *Definitions of Terms Related to Water Resistance*

**Permeability.** Quality or state of permitting passage of water and water vapor into, through, and from pores and interstices, without causing rupture or displacement.

Terms used in this section to describe the permeability of materials, coatings, structural elements, and structures follow in decreasing order of permeability:

**Pervious or Leaky.** Cracks, crevices, leaks, or holes larger than capillary pores, which permit a flow or leakage of water, are present. The material may or may not contain capillary pores.

**Water-resistant.** Capillary pores exist that permit passage of water and water vapor, but there are few or no openings larger than capillaries that permit leakage of significant amounts of water.

**Water-repellent.** Not "wetted" by water; hence, not capable of transmitting water by capillary forces alone. However, the material may allow transmission of water under pressure and may be permeable to water vapor.

**Waterproof.** No openings are present that permit leakage or passage of water and water vapor; the material is impervious to water and water vapor, whether under pressure or not.

These terms also describe the permeability of a surface coating or a treatment against water penetration, and they refer to the permeability of materials, structural members, and structures whether or not they have been coated or treated.

---

\*Excerpted with minor revisions from Sec. 12 of the third edition of this handbook, authored by Cyrus C. Fishburn, formerly with the Division of Building Technology, National Bureau of Standards.



***Permeability of Concrete and Masonry.*** Concrete contains many interconnected voids and openings of various sizes and shapes, most of which are of capillary dimensions. If the larger voids and openings are few in number and not directly connected with each other, there will be little or no water penetration by leakage and the concrete may be said to be water-resistant.

Concrete in contact with water not under pressure ordinarily will absorb it. The water is drawn into the concrete by the surface tension of the liquid in the wetted capillaries.

Water-resistant concrete for buildings should be a properly cured, dense, rich concrete containing durable, well-graded aggregate. The water content of the concrete mix should be as low as is compatible with workability and ease of placing and handling. Resistance of concrete to penetration of water may be improved, however, by incorporation of a water-repellent admixture in the mix during manufacture. (See also Art. 9.9.)

Water-repellent concrete is permeable to water vapor. If a vapor-pressure gradient is present, moisture may penetrate from the exposed face to an inner face. The concrete is not made waterproof (in the full meaning of the term) by the use of an integral water repellent. Note also that water repellents may not make concrete impermeable to penetration of water under pressure. They may, however, reduce absorption of water by the concrete.

Most masonry units also will absorb water. Some are highly pervious under pressure. The mortar commonly used in masonry will absorb water too but usually contains few openings permitting leakage.

Masonry walls may leak at the joints between the mortar and the units, however. Except in single-leaf walls of highly pervious units, leakage at the joints results from failure to fill them with mortar and poor bond between the masonry unit and mortar. As with concrete, rate of capillary penetration through masonry walls is small compared with the possible rate of leakage.

Capillary penetration of moisture through above-grade walls that resist leakage of wind-driven rain is usually of minor importance. Such penetration of moisture into well-ventilated subgrade structures may also be of minor importance if the moisture is readily evaporated. However, long-continued capillary penetration into some deep, confined subgrade interiors frequently results in an increase in relative humidity, a decrease in evaporation rate, and objectionable dampness.

### **3.4.3 Roof Drainage**

Many roof failures have been caused by excessive water accumulation. In most cases, the overload that caused failure was not anticipated in design of those roofs, because the designers expected rainwater to run off the roof. But because of inadequate drainage, the water ponded instead.

On flat roofs, ponding of rainwater causes structural members to deflect. The resulting bowing of the roof surface permits more rainwater to accumulate, and the additional weight of this water causes additional bowing and collection of even more water. This process can lead to roof collapse. Similar conditions also can occur in the valleys of sloping roofs.

To avoid water accumulation, roofs should be sloped toward drains and pipes that have adequate capacity to conduct water away from the roofs, in accordance with local plumbing codes. Minimum roof slope for drainage should be at least  $\frac{1}{4}$  in/ft, but larger slopes are advisable.

The primary drainage system should be supplemented by a secondary drainage system at a higher level to prevent ponding on the roof above that level. The overflow drains should be at least as large as the primary drains and should be connected to drain pipes independent of the primary system or scuppers through the parapets. The roof and its structural members should be capable of sustaining the weight of all rainwater that could accumulate on the roof if part or all of the primary drainage system should become blocked.

### 3.4.4 Drainage for Subgrade Structures

Subgrade structures located above groundwater level in drained soil may be in contact with water and wet soil for periods of indefinite duration after long-continued rains and spring thaws. Drainage of surface and subsurface water, however, may greatly reduce the time during which the walls and floor of a structure are subjected to water, may prevent leakage through openings resulting from poor workmanship and reduce the capillary penetration of water into the structure. If subsurface water cannot be removed by drainage, the structure must be made waterproof or highly water-resistant.

Surface water may be diverted by grading the ground surface away from the walls and by carrying the runoff from roofs away from the building. The slope of the ground surface should be at least  $\frac{1}{4}$  in/ft for a minimum distance of 10 ft from the walls. Runoff from high ground adjacent to the structure should also be diverted.

Proper subsurface drainage of ground water away from basement walls and floors requires a drain of adequate size, sloped continuously, and, where necessary, carried around corners of the building without breaking continuity. The drain should lead to a storm sewer or to a lower elevation that will not be flooded and permit water to back up in the drain.

Drain tile should have a minimum diameter of 6 in and should be laid in gravel or other kind of porous bed at least 6 in below the basement floor. The open joints between the tile should be covered with a wire screen or building paper to prevent clogging of the drain

with fine material. Gravel should be laid above the tile, filling the excavation to an elevation well above the top of the footing. Where considerable water may be expected in heavy soil, the gravel fill should be carried up nearly to the ground surface and should extend from the wall a distance of at least 12 in (Fig. 3.7).

### 3.4.5 Concrete Floors at Grade

Floors on ground should preferably not be constructed in low-lying areas that are wet from ground water or periodically flooded with surface water. The ground

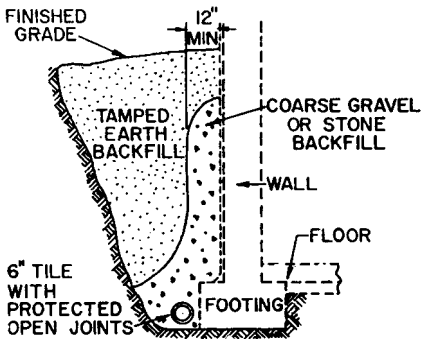

FIGURE 3.7 Drainage at the bottom of a foundation wall.

should slope away from the floor. The level of the finished floor should be at least 6 in above grade. Further protection against ground moisture and possible flooding of the slab from heavy surface runoffs may be obtained with subsurface drains located at the elevation of the wall footings.

All organic material and topsoil of poor bearing value should be removed in preparation of the subgrade, which should have a uniform bearing value to prevent unequal settlement of the floor slab. Backfill should be tamped and compacted in layers not exceeding 6 in in depth.

Where the subgrade is well-drained, as where subsurface drains are used or are unnecessary, floor slabs of residences should be insulated either by placing a granular fill over the subgrade or by use of a lightweight-aggregate concrete slab covered with a wearing surface of gravel or stone concrete. The granular fill, if used, should have a minimum thickness of 5 in and may consist of coarse slag, gravel, or crushed stone, preferably of 1-in minimum size. A layer of 3-, 4-, or 6-in-thick hollow masonry building units is preferred to gravel fill for insulation and provides a smooth, level bearing surface.

Moisture from the ground may be absorbed by the floor slab. Floor coverings, such as oil-base paints, linoleum, and asphalt tile, acting as a vapor barrier over the slab, may be damaged as a result. If such floor coverings are used and where a complete barrier against the rise of moisture from the ground is desired, a two-ply bituminous membrane or other waterproofing material should be placed beneath the slab and over the insulating concrete or granular fill (Fig. 3.8). The top of the lightweight-aggregate concrete, if used, should be troweled or brushed to a smooth level surface for the membrane. The top of the granular fill should be covered with a grout coating, similarly finished. (The grout coat,  $\frac{1}{2}$  to 1 in thick, may consist of a 1:3 or a 1:4 mix by volume of portland cement and sand. Some  $\frac{3}{8}$ - or  $\frac{1}{2}$ -in maximum-sized coarse aggregate may be added to the grout if desired.) After the top surface of the insulating concrete or grout coating has hardened and dried, it should be mopped with hot asphalt or coal-tar pitch and covered before cooling with a lapped layer of 15-lb bituminous saturated felt. The first ply of felt then should be mopped with hot bitumen and a second ply of felt laid and mopped on its top surface. Care should be exercised not to puncture the membrane, which

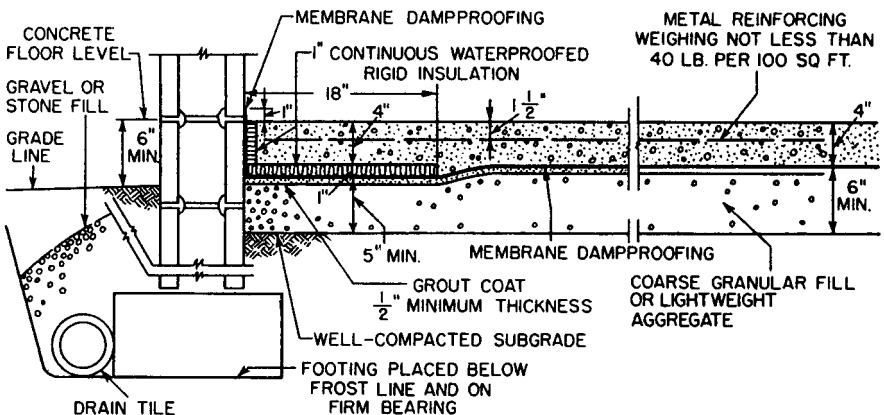

FIGURE 3.8 Insulated concrete slab on ground with membrane dampproofing.

should preferably be covered with a coating of mortar, immediately after its completion. If properly laid and protected from damage, the membrane may be considered to be a waterproof barrier.

Where there is no possible danger of water reaching the underside of the floor, a single layer of 55-lb smooth-surface asphalt roll roofing or an equivalent waterproofing membrane may be used under the floor. Joints between the sheets should be lapped and sealed with bituminous mastic. Great care should be taken to prevent puncturing of the roofing layer during concreting operations. When so installed, asphalt roll roofing provides a low-cost and adequate barrier against the movement of excessive amounts of moisture by capillarity and in the form of vapor. In areas with year-round warm climates, insulation can be omitted.

(“A Guide to the Use of Waterproofing, Dampproofing, Protective and Decorative Barrier Systems for Concrete,” ACI 515.1R, American Concrete Institute.)

### 3.4.6 Basement Floors

Where a basement is to be used in drained soils as living quarters or for the storage of things that may be damaged by moisture, the floor should be insulated and should preferably contain the membrane waterproofing described in Art. 3.4.5 In general the design and construction of such basement floors are similar to those of floors on ground.

If passage of moisture from the ground into the basement is unimportant or can be satisfactorily controlled by air conditioning or ventilation, the waterproof membrane need not be used. The concrete slab should have a minimum thickness of 4 in and need not be reinforced, but should be laid on a granular fill or other insulation placed on a carefully prepared subgrade. The concrete in the slab should have a minimum compressive strength of 2000 psi and may contain an integral water repellent.

A basement floor below the water table will be subjected to hydrostatic upward pressures. The floor should be made heavy enough to counteract the uplift.

An appropriate sealant in the joint between the basement walls and a floor over drained soil will prevent leakage into the basement of any water that may occasionally accumulate under the slab. Space for the joint may be provided by use of beveled siding strips, which are removed after the concrete has hardened. After the slab is properly cured, it and the wall surface should be in as dry a condition as is practicable before the joint is filled to ensure a good bond of the filler and to reduce the effects of slab shrinkage on the permeability of the joint.

(“Guide to Joint Sealants for Concrete Structures,” ACI 504R, American Concrete Institute.)

### 3.4.7 Monolithic Concrete Basement Walls

These should have a minimum thickness of 6 in. Where insulation is desirable, as where the basement is used for living quarters, lightweight aggregate, such as those prepared by calcining or sintering blast-furnace slag, clay, or shale that meet the requirements of ASTM Standard C330 may be used in the concrete. The concrete should have a minimum compressive strength of 2000 psi.

For the forms in which concrete for basement walls is cast, form ties of an internal-disconnecting type are preferable to twisted-wire ties. Entrance holes for the form ties should be sealed with mortar after the forms are removed. If twisted-

wire ties are used, they should be cut a minimum distance of 1½ in inside the face of the wall and the holes filled with mortar.

The resistance of the wall to capillary penetration of water in temporary contact with the wall face may be increased by the use of a water-repellent admixture. The water repellent may also be used in the concrete at and just above grade to reduce the capillary rise of moisture from the ground into the superstructure walls.

Where it is desirable to make the wall resistant to passage of water vapor from the outside and to increase its resistance to capillary penetration of water, the exterior wall face may be treated with an impervious coating. The continuity and the resultant effectiveness in resisting moisture penetration of such a coating is dependent on the smoothness and regularity of the concrete surface and on the skill and technique used in applying the coating to the dry concrete surface. Some bituminous coatings that may be used are listed below in increasing order of their resistance to moisture penetration:

Spray- or brush-applied asphalt emulsions

Spray- or brush-applied bituminous cutbacks

Trowel coatings of bitumen with organic solvent, applied cold

Hot-applied asphalt or coal-tar pitch, preceded by application of a suitable primer

Cementitious brush-applied paints and grouts and trowel coatings of a mortar increase moisture resistance of monolithic concrete, especially if such coatings contain a water repellent. However, in properly drained soil, such coatings may not be justified unless needed to prevent leakage of water through openings in the concrete resulting from segregation of the aggregate and bad workmanship in casting the walls. The trowel coatings may also be used to level irregular wall surfaces in preparation for the application of a bituminous coating. For information on other waterproofing materials, see "A Guide to the Use of Waterproofing, Dampproofing, Protective and Decorative Barrier Systems for Concrete," ACI 515.1R, American Concrete Institute.

### 3.4.8 Unit-Masonry Basement Walls

Water-resistant basement walls of masonry units should be carefully constructed of durable materials to prevent leakage and damage due to frost and other weathering exposure. Frost action is most severe at the grade line and may result in structural damage and leakage of water. Where wetting followed by sudden severe freezing may occur, the masonry units should meet the requirements of the following specifications:

Building brick (solid masonry units made from clay or shale), ASTM Standard C62, Grade SW

Facing brick (solid masonry units made from clay or shale), ASTM Standard C216, Grade SW

Structural clay load-bearing wall tile, ASTM Standard C34, Grade LBX

Hollow load-bearing concrete masonry units, ASTM Standard C90, Grade N

For such exposure conditions, the mortar should be a Type S mortar (Table 4.4) having a minimum compressive strength of 1800 psi when tested in accordance with the requirements of ASTM Standard C270. For milder freezing exposures and

where the walls may be subjected to some lateral pressure from the earth, the mortar should have a minimum compressive strength of 1000 psi.

Leakage through an expansion joint in a concrete or masonry foundation wall may be prevented by insertion of a waterstop in the joint. Waterstops should be of the bellows type, made of 16-oz copper sheet, which should extend a minimum distance of 6 in on either side of the joint. The sheet should be embedded between wythes of masonry units or faced with a 2-in-thick cover of mortar reinforced with welded-wire fabric. The outside face of the expansion joint should be filled flush with the wall face with a joint sealant, as recommended in ACI 504R.

Rise of moisture, by capillarity, from the ground into the superstructure walls may be greatly retarded by use of an integral water-repellent admixture in the mortar. The water-repellent mortar may be used in several courses of masonry located at and just above grade.

The use of shotcrete or trowel-applied mortar coatings,  $\frac{3}{4}$  in or more in thickness, to the outside faces of both monolithic concrete and unit-masonry walls greatly increases their resistance to penetration of moisture. Such plaster coatings cover and seal construction joints and other vulnerable joints in the walls against leakage. When applied in a thickness of 2 in or more, they may be reinforced with welded-wire fabric to reduce the incidence of large shrinkage cracks in the coating. However, the cementitious coatings do not protect the walls against leakage if the walls, and subsequently the coatings, are badly cracked as a result of unequal foundation settlement, excessive drying shrinkage, and thermal changes. ("Guide to Shotcrete," ACI 506, American Concrete Institute.)

Two trowel coats of a mortar containing 1 part portland cement to 3 parts sand by volume should be applied to the outside faces of basement walls built of hollow masonry units. One trowel coat may suffice on the outside of all-brick and of brick-faced walls.

The wall surface and the top of the wall footing should be cleansed of dirt and soil, and the masonry should be thoroughly wetted with water. While still damp, the surface should be covered with a thin scrubbed-on coating of portland cement tempered to the consistency of thick cream. Before this prepared surface has dried, a  $\frac{3}{8}$ -in-thick trowel-applied coating of mortar should be placed on the wall and over the top of the footing; a fillet of mortar may be placed at the juncture of the wall and footing.

Where a second coat of mortar is to be applied, as on hollow masonry units, the first coat should be scratched to provide a rough bonding surface. The second coat should be applied at least 1 day after the first, and the coatings should be cured and kept damp by wetting for at least 3 days. A water-repellent admixture in the mortar used for the second or finish coat will reduce the rate of capillary penetration of water through the walls. If a bituminous coating is not to be used, the mortar coating should be kept damp until the backfill is placed.

Thin, impervious coatings may be applied to the plaster if resistance to penetration of water vapor is desired. (See ACI 515.1R.) The plaster should be dry and clean before the impervious coating is applied over the surfaces of the wall and the top of the footing.

### 3.4.9 Impervious Membranes

These are waterproof barriers providing protection against penetration of water under hydrostatic pressure and water vapor. To resist hydrostatic pressure, a membrane should be made continuous in the walls and floor of a basement. It also should be

protected from damage during building operations and should be laid by experienced workers under competent supervision. It usually consists of three or more alternate layers of hot, mopped-on asphalt or coal-tar pitch and plies of treated glass fabric, or bituminous saturated cotton or woven burlap fabric. The number of moppings exceeds the number of plies by one.

Alternatives are cold-applied bituminous systems, liquid-applied membranes, and sheet-applied membranes, similar to those used for roofing. In installation, manufacturers' recommendations should be carefully followed. See also ACI 515.1R and "The NRCA Waterproofing Manual," National Roofing Manufacturers Association.

Bituminous saturated cotton fabric is stronger and is more extensible than bituminous saturated felt but is more expensive and more difficult to lay. At least one or two of the plies in a membrane should be of saturated cotton fabric to provide strength, ductility, and extensibility to the membrane. Where vibration, temperature changes, and other conditions conducive to displacement and volume changes in the basement are to be expected, the relative number of fabric plies may be increased.

The minimum weight of bituminous saturated felt used in a membrane should be 13 lb per 100 ft<sup>2</sup>. The minimum weight of bituminous saturated woven cotton fabric should be 10 oz/yd<sup>2</sup>.

Although a membrane is held rigidly in place, it is advisable to apply a suitable primer over the surfaces receiving the membrane and to aid in the application of the first mopped-on coat of hot asphalt or coal-tar pitch.

Materials used in the hot-applied system should meet the requirements of the following current ASTM standards:

- Creosote primer for coal-tar pitch—D43
- Primer for asphalt—D41
- Coal-tar pitch—D450, Type II
- Asphalt—D449, Type A
- Cotton fabric, bituminous saturated—D173
- Woven burlap fabric, bituminous saturated—D1327
- Treated glass fabric—D1668
- Coal-tar saturated felt—D227
- Asphalt saturated organic felt—D226

The number of plies of saturated felt or fabric should be increased with increase in the hydrostatic head to which the membrane is to be subjected. Five plies is the maximum commonly used in building construction, but 10 or more plies have been recommended for pressure heads of 35 ft or greater. The thickness of the membrane crossing the wall footings at the base of the wall should be no greater than necessary, to keep very small the possible settlement of the wall due to plastic flow in the membrane materials.

The amount of primer to be used may be about 1 gal per 100 ft<sup>2</sup>. The amount of bitumen per mopping should be at least 4½ gal per 100 ft<sup>2</sup>. The thickness of the first and last moppings is usually slightly greater than the thickness of the moppings between the plies.

The surfaces to which the membrane is to be applied should be smooth, dry, and at a temperature above freezing. Air temperature should be not less than 50°F. The temperature of coal-tar pitch should not exceed 300°F and asphalt, 350°F.

If the concrete and masonry surfaces are not sufficiently dry, they will not readily absorb the priming coat, and the first mopping of bitumen will be accompanied by bubbling and escape of steam. Should this occur, application of the membrane should be stopped and the bitumen already applied to damp surfaces should be removed.

The membrane should be built up ply by ply, the strips of fabric or felt being laid immediately after each bed has been hot-mopped. The lap of succeeding plies or strips over each other depends on the width of the roll and the number of plies. In any membrane there should be a lap of the top or final ply over the first, initial ply of at least 2 in. End laps should be staggered at least 24 in, and the laps between succeeding rolls should be at least 12 in.

**For floors**, the membrane should be placed over a concrete base or subfloor whose top surface is troweled smooth and which is level with the tops of the wall footings. The membrane should be started at the outside face of one wall and extend over the wall footing, which may be keyed. It should cover the floor and tops of other footings to the outside faces of the other walls, forming a continuous horizontal waterproof barrier. The plies should project from the edges of the floor membrane and lap into the wall membrane.

The loose ends of felt and fabric must be protected; one method is to fasten them to a temporary vertical wood form about 2 ft high, placed just outside the wall face. Immediately after the floor membrane has been laid, its surface should be protected and covered with a layer of portland-cement concrete, at least 2 in thick.

**For walls**, the installed membrane should be protected against damage and held in position by protection board or a facing of brick, tile, or concrete block. A brick facing should have a minimum thickness of 2½ in. Facings of asphalt plank, asphalt block, or mortar require considerable support from the membrane itself and give protection against abrasion of the membrane from lateral forces only. Protection against downward forces such as may be produced by settlement of the backfill is given only by the self-supporting masonry walls.

The kind of protective facing may have some bearing on the method of constructing the membrane. The membrane may be applied to the exterior face of the wall after its construction, or it may be applied to the back of the protective facing before the main wall is built. The first of these methods is known as the outside application; the second is known as the inside application.

For the inside application, a protective facing of considerable stiffness against lateral forces must be built, especially if the wall and its membrane are to be used as a form for the casting of a main wall of monolithic concrete. The inner face of the protecting wall must be smooth or else leveled with mortar to provide a suitable base for the membrane. The completed membrane should be covered with a ¾-in-thick layer of mortar to protect it from damage during construction of the main wall.

Application of wall membranes should be started at the bottom of one end of the wall and the strips of fabric or felt laid vertically. Preparation of the surfaces and laying of the membrane proceed much as they do with floor membranes. The surfaces to which the membrane is attached must be dry and smooth, which may require that the faces of masonry walls be leveled with a thin coat of grout or mortar. The plies of the wall membrane should be lapped into those of the floor membrane.

If the outside method of application is used and the membrane is faced with masonry, the narrow space between the units and the membrane should be filled



with mortar as the units are laid. The membrane may be terminated at the grade line by a return into the superstructure wall facing.

Waterstops in joints in walls and floors containing a bituminous membrane should be the metal-bellows type. The membrane should be placed on the exposed face of the joint and it may project into the joint, following the general outline of the bellows.

The protective facing for the membrane should be broken at the expansion joint and the space between the membrane and the line of the facing filled with a joint sealant, as recommended in ACI 504R.

Details at pipe sleeves running through the membrane must be carefully prepared. The membrane should be reinforced with additional plies and may be calked at the sleeve. Steam and hot-water lines should be insulated to prevent damage to the membrane.

### 3.4.10 Above-Grade Walls

The rate of moisture penetration through capillaries in above-grade walls is low and usually of minor importance. However, such walls should not permit leakage of wind-driven rain through openings larger than those of capillary dimension.

*Precast-concrete or metal panels* are usually made of dense, highly water-resistant materials. However, walls made of these panels are vulnerable to leakage at the joints. In such construction, edges of the panels may be recessed and the interior of vertical joints filled with grout or other sealant after the panels are aligned.

Calking compound is commonly used as a facing for the joints. Experience has shown that calking compounds often weather badly; their use as a joint facing creates a maintenance problem and does not prevent leakage of wind-driven rain after a few years' exposure.

The amount of movement to be expected in the vertical joints between panels is a function of the panel dimensions and the seasonal fluctuation in temperature and, for concrete, the moisture content of the concrete. For panel construction, it may be more feasible to use an interlocking water-resistant joint. For concrete, the joint may be faced on the weather side with mortar and backed with either a compressible premolded strip or calking. See ACI 504R.

*Brick walls* 4 in or more in thickness can be made highly water-resistant. The measures that need to be taken to ensure there will be no leakage of wind-driven rain through brick facings are not extensive and do not require the use of materials other than those commonly used in masonry walls. The main factors that need to be controlled are the rate of suction of the brick at the time of laying and filling of all joints with mortar (Art. 11.7).

In general, the greater the number of brick leaves, or wythes, in a wall, the more water-resistant the wall.

*Walls of hollow masonry units* are usually highly permeable, and brick-faced walls backed with hollow masonry units are greatly dependent upon the water resistance of the brick facing to prevent leakage of wind-driven rain. For exterior concrete masonry walls without facings of brick, protection against leakage may be obtained by facing the walls with a cementitious coating of paint, stucco, or shotcrete.

*For wall of rough-textured units*, a portland cement-sand grout provides a highly water-resistant coating. The cement may be either white or gray.

Factory-made portland-cement paints containing a minimum of 65%, and preferably 80%, portland cement may also be used as a base coat on concrete masonry. Application of the paint should conform with the requirements of ACI 515.1R. The paints, stuccos, and shotcrete should be applied to dampened surfaces. Shotcrete should conform with the requirements of ACI 506R.

*Cavity walls*, particularly brick-faced cavity walls, may be made highly resistant to leakage through the wall facing. However, as usually constructed, facings are highly permeable, and the leakage is trapped in the cavity and diverted to the outside of the wall through conveniently located weep holes. This requires that the inner tier of the cavity be protected against the leakage by adequate flashings, and weep holes should be placed at the bottom of the cavities and over all wall openings. The weep holes may be formed by the use of sash-cord head joints or  $\frac{3}{8}$ -in-diameter rubber tubing, withdrawn after the wall is completed.

Flashings should preferably be hot-rolled copper sheet of 10-oz minimum weight. They should be lapped at the ends and sealed either by solder or with bituminous plastic cement. Mortar should not be permitted to drop into the flashings and prevent the weep holes from functioning.

***Prevention of Cracking.*** Shrinkage of concrete masonry because of drying and a drop in temperature may result in cracking of a wall and its cementitious facing. Such cracks readily permit leakage of wind-driven rain. The chief factor reducing incidence of shrinkage cracking is the use of dry block. When laid in the wall, the block should have a low moisture content, preferably one that is in equilibrium with the driest condition to which the wall will be exposed.

The block should also have a low potential shrinkage. See moisture-content requirements in ASTM C90 and method of test for drying shrinkage of concrete block in ASTM C426.

Formation of large shrinkage cracks may be controlled by use of steel reinforcement in the horizontal joints of the masonry and above and below wall openings. Where there may be a considerable seasonal fluctuation in temperature and moisture content of the wall, high-yield-strength, deformed-wire joint reinforcement should be placed in at least 50% of all bed joints in the wall.

Use of control joints faced with calking compound has also been recommended to control shrinkage cracking; however, this practice is marked by frequent failures to keep the joints sealed against leakage of rain. Steel joint reinforcement strengthens a concrete masonry wall, whereas control joints weaken it, and the calking in the joints requires considerable maintenance.

***Water-Resistant Surface Treatments for Above-Grade Walls.*** Experience has shown that leakage of wind-driven rain through masonry walls, particularly those of brick, ordinarily cannot be stopped by use of an inexpensive surface treatment or coating that will not alter the appearance of the wall. Such protective devices either have a low service life or fail to stop all leakage.

Both organic and cementitious pigmented coating materials, properly applied as a continuous coating over the exposed face of the wall, do stop leakage. Many of the organic pigmented coatings are vapor barriers and are therefore unsuitable for use on the outside, "cold" face of most buildings. If vapor barriers are used on the cold face of the wall, it is advisable to use a better vapor barrier on the warm face to reduce condensation in the wall and behind the exterior coating.

Coatings for masonry may be divided into four groups, as follows: (1) colorless coating materials; (2) cementitious coatings; (3) pigmented organic coatings; and (4) bituminous coatings.

*Colorless Coating Materials.* The colorless “waterproofings” are often claimed to stop leakage of wind-driven rain through permeable masonry walls. Solutions of oils, paraffin wax, sodium silicate, chlorinated rubber, silicone resins, and salts of fatty acids have been applied to highly permeable test walls and have been tested at the National Institute of Standards and Technology under exposure conditions simulating a wind-driven rain. Most of these solutions contained not more than 10% of solid matter. These treatments reduced the rate of leakage but did not stop all leakage through the walls. The test data show that colorless coating materials applied to permeable walls of brick or concrete masonry may not provide adequate protection against leakage of wind-driven rain.

Solutions containing oils and waxes tended to seal the pores exposed in the faces of the mortar joints and masonry units, thereby acting more or less as vapor barriers, but did not seal the larger openings, particularly those in the joints.

Silicone water-repellent solutions greatly reduced leakage through the walls as long as the treated wall faces remained water-repellent. After an exposure period of 2 or 3 hr, the rate of leakage gradually increased as the water repellency of the wall face diminished.

Coatings of the water-repellent, breather type, such as silicone and “soap” solutions, may be of value in reducing absorption of moisture into the wall surface. They may be of special benefit in reducing the soiling and disfiguration of stucco facings and light-colored masonry surfaces. They may be applied to precast-concrete panels to reduce volume changes that may otherwise result from changes in moisture content of the concretes. However, it should be noted that a water-repellent treatment applied to the surface may cause water, trapped in the masonry, to evaporate beneath the surface instead of at the surface. If the masonry is not water-resistant and contains a considerable amount of soluble salts, as evidenced by efflorescence, application of a water repellent may cause salts to be deposited beneath the surface, thereby causing spalling of the masonry. The water repellents therefore should be applied only to walls having water-resistant joints. Furthermore, application of a colorless material makes the treated face of the masonry water-repellent and may prevent the proper bonding of a cementitious coating that could otherwise be used to stop leakage.

*Cementitious Coatings.* Coatings of portland-cement paints, grouts, and stuccos and of pneumatically applied mortars are highly water-resistant. They are preferred above all other types of surface coatings for use as water-resistant base coatings on above-grade concrete masonry. They may also be applied to the exposed faces of brick masonry walls that have not been built to be water-resistant.

The cementitious coatings absorb moisture and are of the breather type, permitting passage of water vapor. Addition of water repellents to these coatings does not greatly affect their water resistance but does reduce the soiling of the surface from the absorption of dirt-laden water. If more than one coating is applied, as in a two-coat paint or stucco facing job, the repellent is preferably added only to the finish coat, thus avoiding the difficulty of bonding a cementitious coating to a water-repellent surface.

The technique used in applying the cementitious coatings is highly important. The backing should be thoroughly dampened. Paints and grouts should be scrubbed into place with stiff fiber brushes and the coatings should be properly cured by wetting. Properly applied, the grouts are highly durable; some grout coatings applied to concrete masonry test walls were found to be as water-resistant after 10 years out-of-doors exposure as when first applied to the walls.

*Pigmented Organic Coatings.* These include textured coatings, mastic coatings, conventional paints, and aqueous dispersions. The thick-textured and mastic coatings are usually spray-applied but may be applied by trowel. Conventional paints

and aqueous dispersions are usually applied by brush or spray. Most of these coatings are vapor barriers but some textured coatings, conventional paints, and aqueous dispersions are breathers. Except for the aqueous dispersions, all the coatings are recommended for use with a primer.

Applied as a continuous coating, without pinholes, the pigmented organic coatings are highly water-resistant. They are most effective when applied over a smooth backing. When they are applied with paintbrush or spray by conventional methods to rough-textured walls, it is difficult to level the surface and to obtain a continuous water-resistant coating free from holes. A scrubbed-on cementitious grout used as a base coat on such walls will prevent leakage through the masonry without the use of a pigmented organic coating.

The pigmented organic coatings are highly decorative but may not be so water-resistant, economical, or durable as the cementitious coatings.

*Bituminous Coatings.* Bituminous cutbacks, emulsions, and plastic cements are usually vapor barriers and are sometimes applied as “dampproofers” on the inside faces of masonry walls. Plaster is often applied directly over these coatings, the bond of the plaster to the masonry being only of a mechanical nature. Tests show that bituminous coatings applied to the inside faces of highly permeable masonry walls, not plastered, will readily blister and permit leakage of water through the coating. It is advisable not to depend on such coatings to prevent the leakage of wind-driven rain unless they are incorporated in the masonry or held in place with a rigid self-sustaining backing.

Even though the walls are resistant to wind-driven rain, but are treated on their inner faces with a bituminous coating, water may be condensed on the warm side of the coating and damage to the plaster may result, whether the walls are furred or not. However, the bituminous coating may be of benefit as a vapor barrier in furred walls, if no condensation occurs on the warm side.

See also Secs. 9 and 11.

(“Admixtures for Concrete,” ACI 212.1R; “Guide for Use of Admixtures for Concrete,” ACI 212.2R; “Guide to Joint Sealants for Concrete Structures,” ACI 504R; “Specification for Materials, Proportioning and Application of Shotcrete,” ACI 506.2; “A Guide to the Use of Waterproofing, Dampproofing, Protective and Decorative Barrier Systems for Concrete,” ACI 515.1R; “Specification for Concrete Masonry Construction,” ACI 531.1; “Polymers in Concrete,” ACI 548R; “Guide for the Use of Polymers in Concrete,” ACI 548.1R, American Concrete Institute, P.O. Box 19150, Redford Station, Detroit, MI 48219.)

### **3.5 PROTECTION AGAINST FIRE**

---

There are two distinct aspects of fire protection: life safety and property protection. Although providing for one aspect generally results in some protection for the other, the two goals are not mutually inclusive. A program that provides for prompt notification and evacuation of occupants meets the objectives for life safety, but provides no protection for property. Conversely, it is possible that adequate property protection might not be sufficient for protection of life.

Absolute safety from fire is not attainable. It is not possible to eliminate all combustible materials or all potential ignition sources. Thus, in most cases, an adequate fire protection plan must assume that unwanted fires will occur despite the best efforts to prevent them. Means must be provided to minimize the losses caused by the fires that do occur.

The first obligation of designers is to meet legal requirements while providing the facilities required by the client. In particular, the requirements of the applicable building code must be met. The building code will contain fire safety requirements, or it will specify some recognized standard by reference. Many owners will also require that their own insurance carrier be consulted—to obtain the most favorable insurance rate, if for no other reason.

### 3.5.1 Fire-Protection Standards

The standards most widely adopted are those published by the National Fire Protection Association (NFPA), Batterymarch Park, Quincy, MA 02269. The NFPA “National Fire Codes” comprise several volumes containing numerous standards, updated annually. (These are also available separately.) The standards are supplemented by the NFPA “Fire Protection Handbook,” which contains comprehensive and detailed discussion of fire problems and much valuable statistical and engineering data.

Underwriters Laboratories, Inc. (UL), 333 Pfingsten Road, Northbrook, IL 60062, publishes testing laboratory approvals of devices and systems in its “Fire Protection Equipment List,” updated annually and by bimonthly supplements. The publication outlines the tests that devices and systems must pass to be listed. The UL “Building Materials List” describes and lists building materials, ceiling-floor assemblies, wall and partition assemblies, beam and column protection, interior finish materials, and other pertinent data. UL also publishes lists of “Accident Equipment,” “Electrical Equipment,” “Electrical Construction Materials,” “Hazardous Location Equipment,” “Gas and Oil Equipment,” and others.

Separate standards for application to properties insured by the Factory Mutual System are published by the Factory Mutual Engineering Corporation (FM), Norwood, MA 02062. FM also publishes a list of devices and systems it has tested and approved.

The General Services Administration, acting for the federal government, has developed many requirements that must be considered, if applicable. Also, the federal government encourages cities to adopt some uniform code. In addition, buildings must comply with provisions of the Americans with Disability Act (ADA). (See Department of Justice final rules, *Federal Register*; 28 CFR Part 36, July 26, 1991; American National Standards Institute “Accessibility Standard,” ANSI A117.1; “ADA Compliance Guidebook,” Building Owners and Managers Association International, 1201 New York Ave., Washington, D.C. 20005.)

The Federal Occupational Safety and Health Act (OSHA) sets standards for protecting the health and safety of nearly all employees. It is not necessary that a business be engaged in interstate commerce for the law to apply. OSHA defines **employer** as “a person engaged in a business affecting commerce who has employees, but does not include the United States or any State or political subdivision of a State.”

An employer is required to “furnish to each of his employees employment and a place of employment which are free from recognized hazards that are causing or are likely to cause death or serious physical harm to his employees.” Employers are also required to “comply with occupational safety and health standards promulgated under the Act.”

Building codes consist of a set of rules aimed at providing reasonable safety to the community, to occupants of buildings, and to the buildings themselves. The codes may adopt the standards mentioned previously and other standards concerned with fire protection by reference or adapt them to the specific requirements of the

community. In the absence of a municipal or state building code, designers may apply the provisions of the Uniform Building Code, promulgated by the International Conference of Building Officials, or other national model code.

Many states have codes for safety to life in commercial and industrial buildings, administered by the Department of Labor, the State Fire Marshal's Office, the State Education Department, or the Health Department. Some of these requirements are drastic and must always be considered.

Obtaining optimum protection for life and property can require consultation with the owner's insurance carrier, municipal officials, and the fire department. If the situation is complicated enough, it can require consultation with a specialist in all phases of fire protection and prevention. In theory, municipal building codes are designed for life safety and for protection of the public, whereas insurance-oriented codes (except for NFPA 101, "Life Safety Code") are designed to minimize property fire loss. Since about 70% of any building code is concerned with fire protection, there are many circumstances that can best be resolved by a fire protection consultant.

### 3.5.2 Fire-Protection Concepts

Although fires in buildings can be avoided, they nevertheless occur. Some of the reasons for this are human error, arson, faulty electrical equipment, poor maintenance of heating equipment, and natural causes, such as lightning. Consequently, buildings should be designed to minimize the probability of a fire and to protect life and limit property damage if a fire should occur. The minimum steps that should be taken for the purpose are as follows:

1. Limit potential fire loads, with respect to both combustibility and ability to generate smoke and toxic gases.
2. Provide means for prompt detection of fires, with warnings to occupants who may be affected and notification of the presence of fire to fire fighters.
3. Communication of instructions to occupants as to procedures to adopt for safety, such as to staying in place, proceeding to a designated refuge area, or evacuating the building.
4. Provide means for early extinguishment of any fire that may occur, primarily by automatic sprinklers but also by trained fire fighters.
5. Make available also for fire fighting an adequate water supply, appropriate chemicals, adequate-size piping, conveniently located valves on the piping, hoses, pumps, and other equipment necessary.
6. Prevent spread of fire from building to building, either through adequate separation or by enclosure of the building with incombustible materials.
7. Partition the interior of the building with fire barriers, or divisions, to confine a fire to a limited space.
8. Enclose with protective materials structural components that may be damaged by fire (fireproofing).
9. Provide refuge areas for occupants and safe evacuation routes to outdoors.
10. Provide means for removal of heat and smoke from the building as rapidly as possible without exposing occupants to these hazards, with the air-conditioning

system, if one is present, assisting the removal by venting the building and by pressurizing smokeproof towers, elevator shafts, and other exits.

11. For large buildings, install standby equipment for operation in emergencies of electrical systems and elevators.

These steps are discussed in the following articles.

### 3.5.3 Fire Loads and Resistance Ratings

The nature and potential magnitude of fire in a building are directly related to the amount and physical arrangement of combustibles present, as contents of the building or as materials used in its construction. Because of this, all codes classify buildings by **occupancy** and **construction**, because these features are related to the amount of combustibles.

The total amount of combustibles is called the **fire load** of the building. Fire load is expressed in pounds per square foot (psf) of floor area, with an assumed calorific value of 7000 to 8000 Btu/lb. (This Btu content applies to organic materials similar to wood and paper. Where other materials are present in large proportion, the weights must be adjusted accordingly. For example, for petroleum products, fats, waxes, alcohol, and similar materials, the weights are taken at twice their actual weights, because of the Btu content.)

National Institute of Standards and Technology burnout tests presented in Report BMS92 indicate a relation between fire load and fire severity as shown in Table 3.2.

The temperatures used in standard fire tests of building components are indicated by the internationally recognized time-temperature curve shown in Fig. 3.9. Fire resistance of construction materials, determined by standard fire tests, is expressed in hours. The Underwriters Laboratories "Building Materials List" tabulates fire ratings for materials and assemblies it has tested.

**TABLE 3.2** Relation between Weight of Combustibles and Fire Severity\*

Average weight of combustibles, psf	Equivalent fire severity, hr
5	1/2
7 1/2	3/4
10	1
15	1 1/2
20	2
30	3
40	4 1/2
50	6
60	7 1/2

\*Based on National Institute of Standards and Technology Report BMS92, "Classifications of Building Constructions," Government Printing Office, Washington, D.C. 20402.

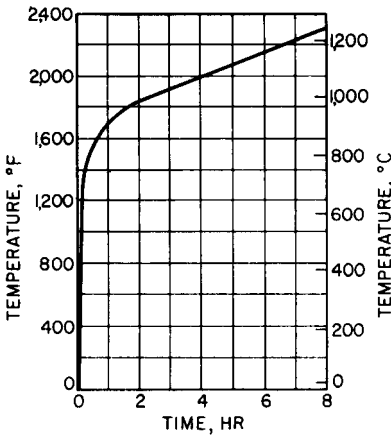

FIGURE 3.9 Time-temperature curve for a standard fire test.

Every building code specifies required fire-resistance ratings for structural members, exterior walls, fire divisions, fire separations, ceiling-floor assemblies, and any other constructions for which a fire rating is necessary. (Fire protection for structural steel is discussed in Arts. 7.49 to 7.53. Design for fire resistance of steel deck in Arts. 8.21.5 and 8.22.4. Design for fire safety with wood construction is covered in Art. 10.28.)

Building codes also specify the ratings required for interior finish of walls, ceilings and floors. These are classified as to flame spread, fuel contributed, and smoke developed, determined in standard tests performed according to ASTM E84 or ASTM E119.

### 3.5.4 Fire and Smoke Barriers

A major consideration in building design is safety of the community. Hence, buildings should be designed to control fires and smoke so that they will not spread from building to building.

One way that building codes try to achieve this objective is to establish fire zones or fire limits that restrict types of construction or occupancy that can be used. Additional zoning regulations establish minimum distances between buildings. Another way to achieve the objective is to specify the types of construction that can be used for enclosing the exterior of buildings. The distance between adjoining buildings, fire rating, and stability when exposed to fire of exterior walls, windows, and doors, and percent of window area are some of the factors taken into account in building codes for determination of the construction classification of a building.

To prevent spread of fire from roof to roof, building codes also often require that exterior walls extend as a parapet at least 3 ft above the roof level. Parapets also are useful in shielding fire fighters who may be hosing a fire from roofs of buildings adjoining the one on fire. In addition, buildings should be topped with roof coverings that are fire-resistant.

**Fire Divisions.** To prevent spread of fire vertically in building interiors, building codes generally require that floor-ceiling and roof-ceiling assemblies be fire-resistant. The fire rating of such assemblies is one of the factors considered in determination of the construction classification of a building. Also, openings in floors and roofs should be fire-protected, although building codes do not usually require this for one-story or two-story dwellings. For the purpose, an opening, such as that for a stairway, may be protected with a fire-resistant enclosure and fire doors. In particular, stairways and escalator and elevator shafts should be enclosed, not only to prevent spread of fire and smoke but also to provide a protected means of egress from the building for occupants and of approach to the fire source by fire fighters.

To prevent spread of fire and smoke horizontally in building interiors, it is desirable to partition interiors with fire divisions. A **fire division** is any construction



with the fire-resistance rating and structural stability under fire conditions required for the type of occupancy and construction of the building to bar the spread of fire between adjoining buildings or between parts of the same building on opposite sides of the division. A fire division may be an exterior wall, fire window, fire door, fire wall, ceiling, or firestop.

A fire wall should be built of incombustible material, have a fire rating of at least 4 hr, and extend continuously from foundations to roof. Also, the wall should have sufficient structural stability in a fire to allow collapse of construction on either side without the wall collapsing. Building codes restrict the size of openings that may be provided in a fire wall and require the openings to be fire-protected (Art. 11.55).

To prevent spread of fire through hollow spaces, such spaces should be fire-stopped. A **firestop** is a solid or compact, tight closure set in a hollow, concealed space in a building to retard spread of flames, smoke, or hot gases. All partitions and walls should be firestopped at every floor level, at the top-story ceiling level, and at the level of support for roofs. Also, very large unoccupied attics should be subdivided by firestops into areas of 3000 ft<sup>2</sup> or less. Similarly, any large concealed space between a ceiling and floor or roof should be subdivided. For the purpose, firestops extending the full depth of the space should be placed along the line of supports of structural members and elsewhere, if necessary, to enclose areas not exceeding 1000 ft<sup>2</sup> when situated between a floor and ceiling or 3000 ft<sup>2</sup> when located between a ceiling and roof.

Openings between floors for pipes, ducts, wiring, and other services should be sealed with the equal of positive firestops. Partitions between each floor and a suspended ceiling above are not generally required to be extended to the slab above unless this is necessary for required compartmentation. But smoke stops should be provided at reasonable intervals to prevent passage of smoke to noninvolved areas.

### 3.5.5 Height and Area Restrictions

Limitations on heights and floor areas included between fire walls in any story of a building are given in every building code and are directly related to occupancy and construction. From the standpoint of fire protection, these provisions are chiefly concerned with safety to life. They endeavor to ensure this through requirements determining minimum number of exits, proper location of exits, and maximum travel distance (hence escape time) necessary to reach a place of refuge. The limitations are also aimed at limiting the size of fires.

Unlimited height and area are permitted for the most highly fire-resistant type of construction. Permissible heights and areas are decreased with decrease in fire resistance of construction. Area permitted between fire walls in any story reduces to 6000 ft<sup>2</sup> for a one-story, wood-frame building.

Installation of automatic sprinklers increases permissible heights and areas in all classes, except those allowed unlimited heights and areas.

Permissible unlimited heights and areas in fire-resistive buildings considered generally satisfactory in the past may actually not be safe. A series of fires involving loss of life and considerable property damage opened the fire safety of such construction to question. As a result, some cities have made more stringent the building-code regulations applicable to high-rise buildings.

Many building codes prohibit floor areas of unlimited size unless the building is sprinklered. Without automatic sprinklers, floor areas must be subdivided into fire-wall-protected areas of from 7500 to 15,000 ft<sup>2</sup> and the enclosing fire walls must have 1- or 2-hr fire ratings, depending on occupancy and construction.

(“Life Safety Handbook” and “Fire Protection Handbook,” National Fire Protection Association, Quincy, Mass.)

### 3.5.6 Fire-Resistance Classification of Buildings

Although building codes classify buildings by occupancy and construction, there is no universal standard for number of classes of either occupancy or construction. Table 3.3 lists some typical occupancy classifications and associates approximate fire loads with them. This table should be used only as a guide. For a specific project refer to the applicable local code. Note, however, that codes do not relate life-safety hazards to the actual fire load, but deal with them through requirements for exit arrangements, interior finishes, and ventilation.

Types of construction may be classified by a local building code as follows but may have further subdivisions, depending on fire-resistance requirements:

1. Fire-resistive construction
2. Protected noncombustible construction
3. Unprotected noncombustible construction
4. Heavy-timber construction
5. Ordinary construction
6. Wood-frame construction

The required fire resistance varies from 4 hr for exterior bearing walls and interior columns in the highest fire resistive class to 1 hr for walls and none for columns in the wood-frame construction class.

**TABLE 3.3** Approximate Fire Loads for Various Occupancies\*

Occupancy class	Typical average fire load including floors and trim, psf
Assembly	10.0
Business	12.6
Educational	7.6
High hazard	†
Industrial	25.0
Institutional	5.7
Mercantile	15–20
Residential	8.8
Storage	30.0

\* From National Institute of Standards and Technology Report BMS92, “Classifications of Building Constructions,” Government Printing Office, Washington, D.C. 20402.

† Special provisions are made for this class, and hazards are treated for the specific conditions encountered, which might not necessarily be in proportion to the actual fire load.

Type of construction affects fire-protection-system design through requirements that structural members as well as contents of buildings be protected.

### 3.5.7 Extinguishment of Fires

Design of all buildings should include provisions for prompt extinguishment of fires. Apparatus installed for the purpose should take into account the nature and amount of combustible and smoke-producing materials that may be involved in a fire. Such apparatus may range from small, hand-held extinguishers for small fires to hoses attached to a large, pressurized water supply and automatic fire sprinklers. Also desirable are fire and smoke detectors and a protective signaling system that sounds an alarm to alert building occupants and calls fire fighters.

**Classes of Fires.** For convenience in defining effectiveness of extinguishing media, Underwriters Laboratories, Inc., has developed a classification that separates combustible materials into four types:

1. *Class A fires* involve ordinary combustibles and are readily extinguishable by water or cooling, or by coating with a suitable chemical powder.
2. *Class B fires* involve flammable liquids where smothering is effective and where a cooling agent must be applied with care.
3. *Class C fires* are those in live electrical equipment where the extinguishing agent must be nonconductive. Since a continuing electrical malfunction will keep the fire source active, circuit protection must operate to cut off current flow, after which an electrically conductive agent can be used with safety.
4. *Class D fires* involve metals that burn, such as magnesium, sodium, and powdered aluminum. Special powders are necessary for such fires, as well as special training for operators. These fires should never be attacked by untrained personnel.

**Automatic Sprinklers.** The most widely used apparatus for fire protection in buildings is the automatic sprinkler system. In one or more forms, automatic sprinklers are effective protection in all occupancy classes. Special treatment and use of additional extinguishing agents, though, may be required in many high-hazard, industrial, and storage occupancies.

Basically, a sprinkler system consists of a network of piping installed at the ceiling or roof and supplied with water from a suitable source. On the piping at systematic intervals are placed heat-sensitive heads, which discharge water when a predetermined temperature is reached at any head. A gate valve is installed in the main supply, and drains are provided. An alarm can be connected to the system so that local and remote signals can be given when the water flows.

Sprinkler systems are suitable for extinguishing all Class A fires and, in many cases, also Class B and C fires. For Class B fires, a sealed (fusible) head system may be used if the flammable liquid is in containers or is not present in large quantity. Sprinklers have a good record for extinguishing fires in garages, for example. An oil-spill fire can be extinguished or contained when the water is applied in the form of spray, as from a sprinkler head. When an oil spill or process-pipe rupture can release flammable liquid under pressure, an open-head (deluge) system may be required to apply a large volume of water quickly and to keep surrounding equipment cool.

For Class C fires, water can be applied to live electrical equipment if it is done in the form of a nonconducting foglike spray. This is usually the most economical way to protect outdoor oil-filled transformers and oil circuit breakers.

Fire protection should be based on complete coverage of the building by the sprinkler system. Partial coverage is rarely advisable, because extinguishing capacity is based on detecting and extinguishing fires in their incipency, and the system must be available at all times in all places. Systems are not designed to cope with fires that have gained headway after starting in unsprinklered areas.

See also Arts. 14.27 to 14.29.

**Standpipes.** Hoses supplied with water from standpipes are the usual means of manual application of water to interior building fires. Standpipes are usually designed for this use by the fire department, but they can be used by building fire fighters also.

Standpipes are necessary in buildings higher than those that ground-based fire department equipment can handle effectively. The Standard Building Code requires standpipes in buildings higher than 50 ft. The Uniform Building Code requirement starts at four stories or occupancies over 5000 ft<sup>2</sup> in area and depends on whether automatic sprinklers are installed.

See also Art. 14.30.

**Chemical Extinguishment.** Fires involving some materials may not be readily extinguished with water alone. When such materials may be present in a building, provision should be made for application of appropriate chemicals.

**Foamed chemicals,** mostly masses of air- or gas-filled bubbles, formed by chemical or mechanical means, may be used to control fires in flammable liquids. Foam is most useful in controlling fires in flammable liquids with low flash points and low specific gravity, such as gasoline. The mass of bubbles forms a cohesive blanket that extinguishes fire by excluding air and cooling the surface.

Foam clings to horizontal surfaces and can also be used on vertical surfaces of process vessels to insulate and cool. It is useful on fuel-spill fires, to extinguish and confine the vapors.

For fire involving water-soluble liquids, such as alcohol, a special foam concentrate must be used. Foam is not suitable for use on fires involving compressed gases, such as propane, nor is it practical on live electrical equipment. Because of the water content, foam cannot be used on fires involving burning metals, such as sodium, which reacts with water. It is not effective on oxygen-containing materials.

Three distinct types of foam are suitable for fire control: chemical foam, air foam (mechanical foam), and high-expansion foam.

**Chemical foam** was the first foam developed for fire fighting. It is formed by the reaction of water with two chemical powders, usually sodium bicarbonate and aluminum sulfate. The reaction forms carbon dioxide, which is the content of the bubbles. This foam is the most viscous and tenacious of the foams. It forms a relatively tough blanket, resistant to mechanical or heat disruption. The volume of expansion may be as much as 10 times that of the water used in the solution.

Chemical foam is sensitive to the temperature at which it is formed, and the chemicals tend to deteriorate during long storage periods. It is not capable of being transported through long pipe lines. For these reasons, it is not used as much as other foams. National Fire Protection Association standard NFPA 11 covers chemical foam.

**Air foam (mechanical foam)** is made by mechanical mixing of water and a protein-based chemical concentrate. There are several methods of combining the components, but essentially the foam concentrate is induced into a flowing stream of water through a metering orifice and a suitable device, such as a venturi. The volume of foam generated is from 16 to 33 times the volume of water used. Several kinds of mixing apparatus are available, choice depending on volume required, availability of water, type of hazard, and characteristics of the protected area or equipment.

Air foam can be conducted through pipes and discharged through a fixed chamber mounted in a bulk fuel storage tank, or it can be conducted through hoses and discharged manually through special nozzles. This foam can also be distributed through a sprinkler system of special design to cover small equipment, such as process vessels, or in multisystem applications, over an entire airplane hangar. The standard for use and installation of air foam is NFPA 11, and for foam-water sprinkler systems, NFPA 16.

**High-expansion foam** was developed for use in coal mines, where its extremely high expansion rate allowed it to be generated quickly in sufficient volume to fill mine galleries and reach inaccessible fires. This foam can be generated in volumes of from 100 to 1000 times the volume of water used, with the latter expansion in most general use. The foam is formed by passage of air through a screen constantly wetted by a solution of chemical concentrate, usually with a detergent base. The foam can be conducted to a fire area by ducts, either fixed or portable, and can be applied manually by small portable generators. Standard for equipment and use of high-expansion foam is NFPA 11A.

High-expansion foam is useful for extinguishing fires by totally flooding indoor confined spaces, as well as for local application to specific areas. It extinguishes by displacing air from the fire and by the heat-absorbing effect of converting the foam water content into steam. The foam forms an insulating barrier for exposed equipment or building components.

High-expansion foam is more fragile than chemical or air foam. Also, it is not generally reliable when used outdoors where it is subject to wind currents. High-expansion foam is not toxic, but it has the effect of disorienting people who may be trapped in it.

**Carbon dioxide** is useful as an extinguishing agent, particularly on surface fires, such as those involving flammable liquids in confined spaces. It is nonconductive and is effective on live electrical equipment. Because carbon dioxide requires no clean-up, it is desirable on equipment such as gasoline or diesel engines. The gas can be used on Class A fires. But when a fire is deep-seated, an extended discharge period is required to avoid rekindling.

Carbon dioxide provides its own pressure for discharge and distribution and is nonreactive with most common industrial materials. Because its density is  $1\frac{1}{2}$  times that of air, carbon dioxide tends to drop and to build up from the base of a fire. Extinguishment of a fire is effected by reduction of the oxygen concentration surrounding a fire.

Carbon dioxide may be applied to concentrated areas or machines by hand-held equipment, either carried or wheeled. Or the gas may be used to flood totally a room containing a hazard. The minimum concentrations for total flooding for fires involving some commercial liquids are listed in "Standard on Carbon-Dioxide Extinguishing Systems," NFPA 12.

Carbon dioxide is not effective on fires involving burning metals, such as magnesium, nor is it effective on oxygen-containing materials, such as nitrocellulose.

Hazard to personnel is involved to the extent that a concentration of 9% will cause suffocation in a few minutes, and concentrations of 20% can be fatal. When used in areas where personnel are present, a time delay before discharge is necessary to permit evacuation.

For use in total flooding systems, carbon dioxide is available in either high-pressure or low-pressure equipment. Generally, it is more economical to use low-pressure equipment for large volumes, although there is no division point applicable in all cases.

**Halon 1301** is one of a series of halogenated hydrocarbons, bromotrifluoromethane (CBrF<sub>3</sub>), used with varying degrees of effectiveness as a fire-extinguishing agent and was included in the Montreal Protocol on Substances that Deplete the Ozone Layer signed in September 16, 1987. It is currently limited to "critical uses" and is planned to be phased out by 2002. The types of uses currently defined as critical are spaces where flammable liquid and/or gas release could occur in the oil, gas, petrochemical and military sectors; manned communication centers of the armed forces or other places essential for national security; or for the protection of spaces where there may be a risk of dispersion of radioactive material.

**Dry chemical extinguishing agents** were used originally to extinguish Class B fires. One type consisted of a sodium bicarbonate base with additives to prevent caking and to improve fluid flow characteristics. Later, multipurpose dry chemicals effective on Class A, B, and C fires were developed. These chemicals are distinctly different from the dry powder extinguishing agents used on combustible metals described below.

Dry chemicals are effective on surface fires, especially on flammable liquids. When used on Class A fires, they do not penetrate into the burning material. So when a fire involves porous or loosely packed material, water is used as a backup. The major effect of dry chemicals is due almost entirely to ability to break the chain reaction of combustion. A minor effect of smothering is obtained on Class A fires.

Fires that are likely to rekindle are not effectively controlled by dry chemicals. When these chemicals are applied to machinery or equipment at high temperatures, caking can cause some difficulty in cleaning up after the fire.

Dry chemicals can be discharged in local applications by hand-held extinguishers, wheeled portable equipment, or nozzles on hose lines. These chemicals can also be used for extinguishing fires by total flooding, when they are distributed through a piped system with special discharge nozzles. The expellant gas is usually dry nitrogen.

**Dry powder extinguishing agents** are powders effective in putting out combustible-metal fires. There is no universal extinguisher that can be used on all fires involving combustible metals. Such fires should never be fought by untrained personnel.

There are several proprietary agents effective on several metals, but none should be used without proper attention to the manufacturer's instructions and the specific metal involved. For requirements affecting handling and processing of combustible metals, reference should be made to National Fire Protection Association standards NFPA 48 and 652 for magnesium, NFPA 481 for titanium, NFPA 482M for zirconium, and NFPA 65 and 651 for aluminum.

("The SFPE Handbook of Fire Protection Engineering," and "Automatic Sprinkler Systems Handbook," National Fire Protection Association, Quincy, Mass.)

### 3.5.8 Fire Detection

Every fire-extinguishing activity must start with detection. To assist in this, many types of automatic detectors are available, with a wide range of sensitivity. Also, a

variety of operations can be performed by the detection system. It can initiate an alarm, local or remote, visual or audible; notify a central station; actuate an extinguishing system; start or stop fans or processes, or perform any other operation capable of automatic control.

There are five general types of detectors, each employing a different physical means of operation. The types are designated *fixed-temperature*, *rate-of-rise*, *photo-electric*, *combustion-products*, and *ultraviolet* or *infrared* detectors.

A wide variety of detectors has been tested and reported on by Underwriters Laboratories, Inc. See Art. 3.5.1.

**Fixed-Temperature Detectors.** In its approval of any detection device, UL specifies the maximum distance between detectors to be used for area coverage. This spacing should not be used without competent judgment. In arriving at the permitted spacing for any device, UL judges the response time in comparison with that of automatic sprinkler heads spaced at 10-ft intervals. Thus, if a device is more sensitive than a sprinkler head, the permitted spacing is increased until the response times are nearly equal. If greater sensitivity is desired, the spacing must be reduced.

With fixed-temperature devices, there is a thermal lag between the time the ambient temperature reaches rated temperature and the device itself reaches that temperature. For thermostats having a rating of 135°F, the ambient temperature can reach 206°F.

**Disk thermostats** are the cheapest and most widely used detectors. The most common type employs the principle of unequal thermal expansion in a bimetallic assembly to operate a snap-action disk at a preset temperature, to close electrical contacts. These thermostats are compact. The disk, 1/2 in in diameter, is mounted on a plastic base 1 3/4 in in diameter. The thermostats are self-resetting, the contacts being disconnected when normal temperature is restored.

**Thermostatic cable** consists of two sheathed wires separated by a heat-sensitive coating which melts at high temperature, allowing the wires to contact each other. The assembly is covered by a protective sheath. When any section has functioned, it must be replaced.

**Continuous detector tubing** is a more versatile assembly. This detector consists of a small-diameter Inconel tube, of almost any length, containing a central wire, separated from the tube by a thermistor element. At elevated temperatures, the resistance of the thermistor drops to a point where a current passes between the wire and the tube. The current can be monitored, and in this way temperature changes over a wide range, up to 1000°F, can be detected. The detector can be assembled to locate temperature changes of different magnitudes over the same length of detector. It is self-restoring when normal temperature is restored. This detector is useful for industrial applications, as well as for fire detection.

**Fusible links** are the same devices used in sprinkler heads and are made to operate in the same temperature range. Melting or breaking at a specific temperature, they are used to restrain operation of a fire door, electrical switch, or similar mechanical function, such as operation of dampers. Their sensitivity is substantially reduced when installed at a distance below a ceiling or other heat-collecting obstruction.

**Rate-of-Rise Detectors.** Detectors and detector systems are said to operate on the rate-of-rise principle when they function on a rapid increase in temperature, whether the initial temperature is high or low. The devices are designed to operate when temperature rises at a specified number of degrees, usually 10 or 15°F, per minute. They are not affected by normal temperature increases and are not subject to thermal lag, as are fixed-temperature devices.

**Photoelectric Detectors.** These indicate a fire condition by detecting the smoke. Sensitivity can be adjusted to operate when obscuration is as low as 0.4% per ft. In these devices, a light source is directed so that it does not impinge on a photoelectric cell. When sufficient smoke particles are concentrated in the chamber, their reflected light reaches the cell, changing its resistance and initiating a signal.

These detectors are particularly useful when a potential fire is likely to generate a substantial amount of smoke before appreciable heat and flame erupt. A fixed-temperature, snap-action disk is usually included in the assembly.

**Combustion-Products Detectors.** Two physically different means, designated ionization type and resistance-bridge type, are used to operate combustion-products detectors.

The **ionization type**, most generally used, employs ionization of gases by alpha particles emitted by a small quantity of radium or americium. The detector contains two ionization chambers, one sealed and the other open to the atmosphere, in electrical balance with a cold-cathode tube or transistorized amplifier. When sufficient combustion products enter the open chamber, the electrical balance is upset, and the resulting current operates a relay.

The **resistance-bridge type** of detector operates when combustion products change the impedance of an electric bridge grid circuit deposited on a glass plate.

Combustion-products detectors are designed for extreme early warning, and are most useful when it is desirable to have warning of impending combustion when combustion products are still invisible. These devices are sensitive in some degree to air currents, temperature, and humidity, and should not be used without consultation with competent designers.

**Flame Detectors.** These discriminate between visible light and the light produced by combustion reactions. Ultraviolet detectors are responsive to flame having wavelengths up to 2850 Å. The effective distance between flame and detectors is about 10 ft for a 5-in-diam pan of gasoline, but a 12-in-square pan fire can be detected at 30 ft.

Infrared detectors are also designed to detect flame. These are not designated by range of wavelength because of the many similar sources at and above the infrared range. To identify the radiation as a fire, infrared detectors usually employ the characteristic flame flicker, and have a built-in time delay to eliminate accidental similar phenomena.

(“The SFPE Handbook of Fire Detection Engineering,” National Fire Protection Association, Quincy, Mass.)

### 3.5.9 Smoke and Heat Venting

In extinguishment of any building fire, the heat-absorption capacity of water is the principal medium of reducing the heat release from the fire. When, however, a fire is well-developed, the smoke and heat must be released from confinement to make the fire approachable for final manual action. If smoke and heat venting is not provided in the building design, holes must be opened in the roof or building sides by the fire department. In many cases, it has been impossible to do this, with total property losses resulting.

Large-area, one-story buildings can be provided with venting by use of monitors, or a distribution of smaller vents. Multistory buildings present many problems, particularly since life safety is the principal consideration in these buildings.



Ventilation facilities should be provided in addition to the protection afforded by automatic sprinklers and hose stations.

**Large One-Story Buildings.** For manufacturing purposes, low buildings are frequently required to be many hundreds of feet in each horizontal dimension. Lack of automatic sprinklers in such buildings has proven to be disastrous where adequate smoke and heat venting has not been provided. Owners generally will not permit fire division walls, because they interfere with movement and processing of materials. With the whole content of a building subject to the same fire, fire protection and venting are essential to prevent large losses in windowless buildings underground structures, and buildings housing hazardous operations.

There is no accepted formula for determining the exact requirements for smoke and heat venting. Establishment of guidelines is the nearest approach that has been made to venting design, and these must be adapted to the case at hand. Consideration must be given to quantity, shape, size, and combustibility of contents.

**Venting Ratios.** The ratio of effective vent opening to floor area should be at least that given in Table 3.4.

Venting can be accomplished by use of monitors, continuous vents, unit-type vents, or sawtooth skylights. In moderate-sized buildings exterior-wall windows may be used if they are near the eaves.

Monitors must be provided with operable panels or other effective means of providing openings at the required time.

Continuous gravity vents are continuous narrow slots provided with a weather hood above. Movable shutters can be provided and should be equipped to open automatically in a fire condition.

**Vent Spacing.** Unit-type vents are readily adapted to flat roofs, and can be installed in any required number, size, and spacing. They are made in sizes from  $4 \times 4$  ft to  $10 \times 10$  ft, with a variety of frame types and means of automatic opening. In arriving at the number and size of vents, preference should be given to a large number of small vents, rather than a few large vents. Because it is desirable to have a vent as near as possible to any location where a fire can start, a limit should be placed on the distance between units. Table 3.5 lists the generally accepted maximum distance between vents.

**Releasing Methods.** Roof vents should be automatically operated by means that do not require electric power. They also should be capable of being manually operated. Roof vents approved by Underwriters Laboratories, Inc., are available from a number of manufacturers.

Refer to National Fire Protection Association standard NFPA 204 in designing vents for large, one-story buildings. Tests conducted prior to publication of NFPA 231C indicated that a sprinkler system designed for adequate density of water application will eliminate the need for roof vents, but the designers would be well advised to consider the probable speed of fire and smoke development in making a final decision. NFPA 231C covers the rack storage of materials as high as 20 ft.

**TABLE 3.4** Minimum Ratios of Effective Vent Area to Floor Area

Low-heat-release contents	1:150
Moderate-heat-release contents	1:100
High-heat-release contents	1:30–1:50

**TABLE 3.5** Maximum Distance between Vents, Ft

Low-heat-release contents	150
Moderate-heat-release contents	120
High-heat-release contents	75–100

**High-Rise Buildings.** Building codes vary in their definition of high-rise buildings, but the intent is to define buildings in which fires cannot be fought successfully by ground-based equipment and personnel. Thus, ordinarily, high-rise means buildings 100 ft or more high. In design for smoke and heat venting, however, any multistory building presents the same problems.

Because smoke inhalation has been the cause of nearly all fatalities in high-rise buildings, some building codes require that a smoke venting system be installed and made to function independently of the air-conditioning system. Also, smoke detectors must be provided to actuate exhaust fans and at the same time warn the fire department and the building's control center. The control center must have two-way voice communication, selectively, with all floors and be capable of issuing instructions for occupant movement to a place of safety.

Because the top story is the only one that can be vented through the roof, all other stories must have the smoke conducted through upper stories to discharge safely above the roof. A separate smoke shaft extending through all upper stories will provide this means. It should be provided with an exhaust fan and should be connected to return-air ducts with suitable damper control of smoke movement, so that smoke from any story can be directed into the shaft. The fan and dampers should be actuated by smoke detectors installed in suitable locations at each inlet to return-air ducts. Operation of smoke detectors also should start the smoke-vent-shaft fan and stop supply-air flow. Central-station supervision (Art. 3.5.12) should be provided for monitoring smoke-detector operation. Manual override controls should be installed in a location accessible under all conditions.

Windows with fixed sash should be provided with means for emergency opening by the fire department.

Pressurizing stair towers to prevent the entrance of smoke is highly desirable but difficult to accomplish. Most standpipe connections are usually located in stair towers, and it is necessary to open the door to the fire floor to advance the hose stream toward the fire. A more desirable arrangement would be to locate the riser in the stair tower, if required by code, and place the hose valve adjacent to the door to the tower. Some codes permit this, and it is adaptable to existing buildings.

(“The SFPE Handbook of Fire Protection Engineering,” National Fire Protection Association, Quincy, Mass.)

### 3.5.10 Emergency Egress

In addition to providing means for early detection of fire, preventing its spread, and extinguishing it speedily, building designers should also provide the appropriate number, sizes, and arrangements of exits to permit quick evacuation of occupants if fire or other conditions dangerous to life occur. Buildings should be designed to preclude development of panic in emergencies, especially in confined areas where large numbers of persons may assemble. Hence, the arrangement of exit facilities should permit occupants to move freely toward exits that they can see clearly and that can be reached by safe, unobstructed, uncongested paths. Redundancy is highly desirable; there should be more than one path to safety, so that loss of a single path will not prevent escape of occupants from a danger area. The paths should be accessible to and usable by handicapped persons, including those in wheelchairs, if they may be occupants.

Building codes generally contain requirements for safe, emergency egress from buildings. Such requirements also are concisely presented in the “Life Safety Code” of the National Fire Protection Association.

**Egress Components.** Many building codes define an exit as a safe means of egress from the interior of a building to an open exterior space beyond the reach of a building fire or give an equivalent definition. Other codes consider an exterior door or a stairway leading to access to such a door to be an exit. To prevent misunderstandings, the “Life Safety Code” defines a means of egress composed of three parts.

Accordingly, a **means of egress** is a continuous, unobstructed path for evacuees from any point in a building to a public way. Its three parts are:

**Exit access**—that portion that leads to an entrance to an exit

**Exit**—the portion that is separated from all other building spaces by construction or equipment required to provide a protected path to the exit discharge

**Exit discharge**—the portion that connects the termination of an exit to a public way

Means of egress may be provided by exterior and interior doors and enclosed horizontal and vertical passageways, including stairs and escalators. (Elevators and exterior fire escapes are not generally recognized as reliable means of egress in a fire.) Exit access includes the space from which evacuation starts and passageways and doors that must be traversed to reach an exit.

**Types of Exits.** Building codes generally recognize the following as acceptable exits when they meet the codes’ safety requirements:

**Corridors**—enclosed horizontal or slightly inclined public passageways, which lead from interior spaces toward an exit discharge. Minimum floor-to-ceiling height permitted is generally 80 in. Minimum width depends on type of occupancy and passageway (Table 3.7 and Art. 3.5.11). Codes may require subdivision of corridors into lengths not exceeding 300 ft for educational buildings and 150 ft for institutional buildings. Subdivision should be accomplished with noncombustible partitions incorporating smokestop doors. In addition, codes may require the corridor enclosures to have a fire rating of 1 or 2 hr.

**Exit passageways**—horizontal extensions of vertical passageways. Minimum floor-to-ceiling height is the same as for corridors. Width should be at least that of the vertical passageways. Codes may require passageway enclosures to have a 2-hr fire rating. A street-floor lobby may serve as an exit passageway if it is sufficiently wide to accommodate the probable number of evacuees from all contributing spaces at the lobby level.

**Exit doors**—doors providing access to streets or to stairs or exit passageways. Those at stairs or passageways should have a fire rating of at least  $\frac{3}{4}$  hr.

**Horizontal exit**—passageway to a refuge area. The exit may be a fire door through a wall with a 2-hr fire rating, a balcony providing a path around a fire barrier, or a bridge or tunnel between two buildings. Doors in fire barriers with 3- or 4-hr fire ratings should have a 1½-hr rated door on each face of the fire division. Walls permitted to have a lower fire rating may incorporate a single door with a rating of at least 1½ hr. Balconies, bridges, and tunnels should be at least as wide as the doors providing access to them, and enclosures or sides of these passageways should have a fire rating of 2 hr or more. Exterior-wall openings, below or within 30 ft of an open bridge or balcony, should have at least  $\frac{3}{4}$ -hr fire protection.

**Interior stairs**—stairs that are inside a building and that serve as an exit. Except in one-story or two-story low-hazard buildings, such stairs should be built of noncombustible materials. Stairway enclosures generally should have a 2-hr fire rating. Building codes, however, may exempt low dwellings from this requirement.

**Exterior stairs**—stairs that are open to the outdoors and that serve as an exit to ground level. Height of such stairs is often limited to 75 ft or six stories. The stairs should be protected by a fire-resistant roof and should be built of noncombustible materials. Wall openings within 10 ft of the stairs should have  $\frac{3}{4}$ -hr fire protection.

**Smokeproof tower**—a continuous fire-resistant enclosure protecting a stairway from fire or smoke in a building. At every floor, a passageway should be provided by vestibules or balconies directly open to the outdoors and at least 40 in wide. Tower enclosures should have a 2-hr fire rating. Access to the vestibules or balconies and entrances to the tower should be provided by doorways at least 40 in wide, protected by self-closing fire doors.

**Escalators**—moving stairs. Building codes may permit their use as exits if they meet the safety requirements of interior stairs and if they move in the direction of exit travel or stop gradually when an automatic fire-detection system signals a fire.

**Moving walks**—horizontal or inclined conveyor belts for passengers. Building codes may permit their use as exits if they meet the safety requirements for exit passageways and if they move in the direction of exit travel or stop gradually when an automatic fire-detection system signals a fire.

**Refuge Areas.** A refuge area is a space protected against fire and smoke. When located within a building, the refuge should be at about the same level as the areas served and separated from them by construction with at least a 2-hr fire rating. Access to the refuge areas should be protected by fire doors with a fire rating of  $1\frac{1}{2}$  hr or more.

A refuge area should be large enough to shelter comfortably its own occupants plus those from other spaces served. The minimum floor area required may be calculated by allowing 3 ft<sup>2</sup> of unobstructed space for each ambulatory person and 30 ft<sup>2</sup> per person for hospital or nursing-home patients. Each refuge area should be provided with at least one horizontal or vertical exit, such as a stairway, and in locations more than 11 stories above grade, with at least one elevator.

**Location of Exits.** Building codes usually require a building to have at least two means of egress from every floor. Exits should be remote from each other, to reduce the chance that both will be blocked in an emergency.

All exit access facilities and exits should be located so as to be clearly visible to building occupants or signs should be installed to indicate the direction of travel to the exits. Signs marking the locations of exits should be illuminated with at least 5 ft-c of light. Floors of means of egress should be illuminated with at least 1 ft-c of artificial light whenever the building is occupied.

If an open floor area does not have direct access to an exit, a protected, continuous passageway should be provided directly to an exit. The passageway should be kept open at all times. Occupants using the passageway should not have to pass any high-hazard areas not fully shielded.

To ensure that occupants will have sufficient escape time in emergencies, building codes limit the travel distance from the most remote point in any room or space to a door that opens to an outdoor space, stairway, or exit passageway. The maximum travel distance permitted depends on the type of occupancy and whether the space is sprinklered. For example, for corridors not protected by sprinklers, maximum permitted length may range from 100 ft for storage and institutional buildings to 150 ft for residential, mercantile, and industrial occupancies. With sprinkler protection, permitted length may range from 150 ft for high-hazard and storage buildings to 300 ft for commercial buildings, with 200 ft usually permitted for other types of occupancies.

Building codes also may prohibit or limit the lengths of passageways or courts that lead to a dead end. For example, a corridor that does not terminate at an exit is prohibited in high-hazard buildings. For assembly, educational, and institutional buildings, the maximum corridor length to a dead end may not exceed 30 ft, whereas the maximum such length is 40 ft for residential buildings and 50 ft for all other occupancies, except high-hazard.

### 3.5.11 Required Exit Capacity

Minimum width of a passageway for normal use is 36 in. This is large enough to accommodate one-way travel for persons on crutches or in wheelchairs. For two-way travel, a 60-in width is necessary. (A corridor, however, need not be 60 in wide for its full length, if 60 × 60-in passing spaces, alcoves, or corridor intersections are provided at short intervals.) Building codes, however, may require greater widths to permit rapid passage of the anticipated number of evacuees in emergencies. This number depends on a factor called the occupant load, but the minimum width should be ample for safe, easy passage of handicapped persons. Running slope should not exceed 1:20, and cross slope, 1:50.

**Occupant load** of a building space is the maximum number of persons that may be in the space at any time. Building codes may specify the minimum permitted capacity of exits in terms of occupant load, given as net floor area, square feet, per person, for various types of occupancy (Table 3.6). The number of occupants permitted in a space served by the exits then can be calculated by dividing the floor area, square feet, by the specified occupant load.

The occupant load of any space should include the occupant load of other spaces if the occupants have to pass through that space to reach an exit.

With the occupant load known, the required width for an exit or an exit door can be determined by dividing the occupant load on the exit by the capacity of the exit.

Capacities of exits and access facilities generally are measured in units of width of 22 in, and the number of persons per unit of width is determined by the type of occupancy. Thus, the number of units of exit width for a doorway is found by dividing by 22 the clear width of the doorway when the door is in the open position. (Projections of stops and hinge stiles may be disregarded.) Fractions of a unit of width less than 12 in should not be credited to door capacity. If, however, 12 in or more is added to a multiple of 22 in, one-half unit of width can be credited. Building codes indicate the capacities in persons per unit of width that may be assumed for various means of egress. Recommendations of the “Life Safety Code” of the National Fire Protection Association, Batterymarch Park, Quincy, MA 02269, are summarized in Table 3.7.

**TABLE 3.6** Typical Occupant Load Requirements for Types of Occupancy

Occupancy	Net floor area per occupant, ft <sup>2</sup>
Auditoriums	7
Billiard rooms	50
Bowling alleys	50
Classrooms	20
Dance floors	7
Dining spaces (nonresidential)	12
Exhibition spaces	10
Garages and open parking structures	250
Gymnasiums	15
Habitable rooms	200
Industrial shops	200
In schools	50
Institutional sleeping rooms	120
Kindergartens	35
Kitchens (nonresidential)	200
Laboratories	50
Preparation rooms	100
Libraries	25
Locker rooms	12
Offices	100
Passenger terminals or platforms	1.5C*
Sales areas (retail)	30
First floor or basement	
Other floors	60
Seating areas (audience) in places of assembly	D†
Fixed seats	
Movable seats	10
Skating rinks	15
Stages	S‡
Storage rooms	300

\*C = capacity of all passenger vehicles that can be unloaded simultaneously.

†D = number of seats or occupants for which space is to be used.

‡S = 75 persons per unit of width of exit openings serving a stage directly, or one person per 15 ft of performing area plus one person per 50 ft<sup>2</sup> of remaining area plus number of seats that may be placed for an audience on stage.

**TABLE 3.7** Capacities, Persons per Unit of Width, for Means of Egress

Level egress components, including doors	100
Stairway	60
Ramps 44 in or more wide, slope not more than 10%	100
Narrower or steeper ramps	
Up	60
Down	100

### 3.5.12 Building Operation in Emergencies

For buildings that will be occupied by large numbers of persons, provision should be made for continuation of services essential to safe, rapid evacuation of occupants in event of fire or other emergencies and for assisting safe movement of fire fighters, medical personnel, or other aides.

Standby electric power, for example, should be available in all buildings to replace the basic power source if it should fail. The standby system should be equipped with a generator that will start automatically when normal power is cut off. The emergency power supply should be capable of operating all emergency electric equipment at full power within 1 min of failure of normal service. Such equipment includes lights for exits, elevators for fire fighters' use, escalators and moving walks designated as exits, exhaust fans and pressurizing blowers, communication systems, fire detectors, and controls needed for fire fighting and life safety during evacuation of occupants.

In high-rise buildings, at least one elevator should be available for control by fire fighters and to give them access to any floor from the street-floor lobby. Also, elevator controls should be designed to preclude elevators from stopping automatically at floors affected by fire.

Supervision of emergency operations can be efficiently provided by personnel at a control center placed in a protected area. This center may include a computer, supplemented by personnel performing scheduled maintenance, and should be capable of continuously monitoring alarms, gate valves on automatic fire sprinklers, temperatures, air and water pressures, and perform other pertinent functions. Also, the center should be capable in emergencies of holding two-way conversations with occupants and notifying police and fire departments of the nature of the emergencies. In addition, provision should be made for the control center to dispatch investigators to sources of potential trouble or send maintenance personnel to make emergency repairs when necessary. Standards for such installations are NFPA 72A, "Local Protective Signaling Systems," NFPA 72B, "Auxiliary Protective Signaling Systems," NFPA 72C, "Remote Station Protective Signaling Systems," and NFPA 72D, "Proprietary Protective Signaling Systems." See also Art. 3.7.2.

For economical building operation, the emergency control center may be made part of a control center used for normal building operation and maintenance. Thus, the control center may normally control HVAC to conserve energy, turn lights on and off, and schedule building maintenance and repair. When an emergency occurs, emergency control should be activated in accordance with prepared plans for handling each type of emergency.

The control center need not be located within the building to be supervised nor operated by in-house personnel. Instead, an external central station may provide the

necessary supervision. Such services are available in most cities and are arranged by contract, usually with an installation charge and an annual maintenance charge. Requirements for such systems are in National Fire Protection Association standard NFPA 71.

### **3.5.13 Safety during Construction**

Most building codes provide specific measures that must be taken for fire protection during construction of buildings. But when they do not, fundamental fire-safety precautions must be taken. Even those structures that will, when completed, be noncombustible contain quantities of forming and packing materials that present a serious fire hazard.

Multistory buildings should be provided with access stairways and, if applicable, an elevator for fire department use. Stairs and elevator should follow as closely as possible the upward progress of the structure and be available within one floor of actual building height. In buildings requiring standpipes, the risers should be placed in service as soon as possible, and as close to the construction floor as practicable. Where there is danger of freezing, the water supply can consist of a Siamese connection for fire department use.

In large-area buildings, required fire walls should be constructed as soon as possible. Competent watchman service also should be provided.

The greatest source of fires during construction is portable heaters. Only the safest kind should be used, and these safeguarded in every practical way. Fuel supplies should be isolated and kept to a minimum.

Welding operations also are a source of fires. They should be regulated in accordance with building-code requirements.

Control of tobacco smoking is difficult during building construction, so control of combustible materials is necessary. Good housekeeping should be provided, and all combustible materials not necessary for the work should be removed as soon as possible.

Construction offices and shanties should be equipped with adequate portable extinguishers. So should each floor in a multistory building.

## **3.6 LIGHTNING PROTECTION**

---

Lightning, a high-voltage, high-current electrical discharge between clouds and the ground, may strike and destroy life and property anywhere thunderstorms have occurred in the past. Buildings and their occupants, however, can be protected against this hazard by installation of a special electrical system. Because an incomplete or poor installation can cause worse damage or injuries than no protection at all, a lightning-protection system should be designed and installed by experts.

As an addition to other electrical systems required for a building, a lightning-protection system increases the construction cost of a building. A building owner therefore has to decide whether potential losses justify the added expenditure. In doing so, the owner should take into account the importance of the building, danger to occupants, value and nature of building contents, type of construction, proximity of other structures or trees, type of terrain, height of building, number of days per



year during which thunderstorms may occur, costs of disruption of business or other activities and the effects of loss of essential services, such as electrical and communication systems. (Buildings housing flammable or explosive materials generally should have lightning protection.) Also, the owner should compare the cost of insurance to cover losses with the cost of the protection system.

### 3.6.1 Characteristics of Lightning

Lightning strikes are associated with thunderstorms. In such storms, the base of the clouds generally develops a negative electrical charge, which induces a positive charge in the earth directly below. As the clouds move, the positive charges, being attracted by the negative charges, follow along the surface of the earth and climb up buildings, antennas, trees, power transmission towers, and other conducting or semiconducting objects along the path. The potential between clouds and earth may build up to  $10^6$  to  $10^9$  V. When the voltage becomes great enough to overcome the electrical resistance of the air between the clouds and the ground or an object on it, current flows in the form of a lightning flash. Thus, the probability of a building being struck by lightning depends not only on the frequency of occurrence of thunderstorms but also on building height relative to nearby objects and the intensity of cloud charges.

Destruction at the earth's surface may result not only at points hit by lightning directly but also by electrostatic induction at points several feet away. Also, lightning striking a tall object may flash to a nearby object that offers a suitable path to the ground.

Lightning often shatters nonconductors or sets them on fire if they are combustible. Conductors struck may melt. Living things may be burned or electrocuted. Also, lightning may induce overvoltages in electrical power lines, sending electrical charges along the lines in both directions from the stricken point to ground. Direct-stroke overvoltages may range up to several million volts and several hundred thousand amperes. Induced strokes, which occur more frequently, may be on the order of several hundred thousand volts with currents up to 2000 A. Such overvoltages may damage not only electric equipment connected to the power lines but also buildings served by them. Consequently, lightning protection is necessary for outdoor conductors as well as for buildings.

### 3.6.2 Methods for Protecting against Lightning

Objectives of lightning protection are life safety, prevention of property damage, and maintenance of essential services, such as electrical and communication systems. Lightning protection usually requires installation of electrical conductors that extend from points above the roof of a building to the ground, for the purpose of conducting to the ground lightning that would otherwise strike the building. Such an installation, however, possesses the potential hazard that, if not done properly, lightning may flash from the lightning conductors to other building components. Hence, the system must ensure that the lightning discharge is diverted away from the building and its contents. Lightning protection systems should conform to the standards of the American National Standards Institute, National Fire Protection Association (NFPA 78, "Lightning Protection Code") and Underwriters Laboratories (UL 96A, "Master Labeled Lightning-Protection Systems").

The key element in diverting lightning away from a building is an air terminal or lightning rod, a conductor that projects into the air at least 12 in above the roof. Air terminals should be spaced at intervals not exceeding 25 ft. Alternatively, a continuous wire conductor or a grid of such conductors may be placed along the highest points of a roof. If the tallest object on a roof is a metal mast, it can act as an air terminal. A metal roof also can serve as an air terminal, but only if all joints are made electrically continuous by soldering, welding, or interlocking. Arranged to provide a cone of protection over the entire building, all the air terminals should be connected by conductors to each other and, by the same or other conductors, to the ground along at least two separated paths.

For roof and down conductors, copper, copper-clad steel, galvanized steel or a metal alloy that is as resistant to corrosion as copper may be used. (A solid copper conductor should be at least  $\frac{1}{4}$  in in diameter.) Direct connections between dissimilar metals should be avoided to prevent corrosion. Metal objects and non-current-carrying components of electrical systems should be kept at least 6 ft away from the lightning conductors or should be bonded to the nearest lightning conductor. Sharp bends in the conductors are not desirable. If a 90° bend must be used, the conductor should be firmly anchored, because the high current in a lightning stroke will tend to straighten the bend. If the conductor has a U bend, the high current may induce an electric arc to leap across the loop while also exerting forces to straighten out the bend.

In steel-frame buildings, the steel frame can be used as a down conductor. In such cases, the top of the frame should be electrically connected to air terminals and the base should be electrically connected to grounding electrodes. Similarly, the reinforcing steel of a reinforced concrete building can be used as down conductors if the reinforcing steel is bonded together from foundations to roof.

Damage to the electrical systems of buildings can be limited or prevented by insertion of lightning arresters, safety valves that curtail overvoltages and bypass the current surge to a ground system, at the service entrance. Further protection can be afforded electrical equipment, especially sensitive electronic devices, by installing surge protectors, or spark gaps, near the equipment.

The final and equally important elements of a lightning-protection system are grounding electrodes and the earth itself. The type and dimensions of the grounds, or grounding electrodes, depends on the electrical resistance, or resistivity, of the earth, which can be measured by technicians equipped with suitable instruments. The objective of the grounding installation, which should be electrically bonded to the down conductors, should be an earth-system resistance of 10  $\Omega$  or less. Underground water pipes can serve as grounds if they are available. If not, long metal rods can be driven into the ground to serve as electrodes. Where earth resistivity is poor, an extensive system of buried wires may be required.

(J. L. Marshall, "Lightning Protection," John Wiley & Sons, Inc., New York.)

### **3.7 PROTECTION AGAINST INTRUDERS**

---

Prevention of illegal entry into buildings by professional criminals determined to break in is not practical. Hence, the prime objective of security measures is to make illegal entry difficult. If this is done, it will take an intruder longer to gain entry or will compel the intruder to make noise, thus increasing the chances of detection and apprehension. Other objectives of security measures are detection of break-in

attempts and intruders, alarming intruders so that they leave the premises before they cause a loss or injury, and alerting building occupants and the police of the break-in attempt. Also, an objective is to safeguard valuable assets by placing them in a guarded, locked, secure enclosure with access limited only to approved personnel.

Some communities have established ordinances setting minimum requirements for security and incorporated them in the building code. (Communities that have done this include Los Angeles, Oakland, and Concord in California; Indianapolis, Ind.; Trenton, N.J.; Arlington Heights, Ill.; Arlington County, Va.; and Prince George's County, Md.) Provisions of these codes cover security measures for doors and windows and associated hardware, accessible transoms, roof openings, safes, lighting of parking lots, and intrusion-detection devices. For buildings requiring unusual security measures, owners and designers should obtain the advice of a security expert.

### **3.7.1 Security Measures**

Basic security for a building is provided by commonly used walls and roofs with openings protected by doors with key-operated locks or windows with latches. The degree of protection required for a building and its occupants beyond basic security and privacy needs depends on the costs of insurance and security measures relative to potential losses from burglary and vandalism.

For a small building not housing small items of great value (these can be placed in a safety deposit box in a bank), devices for detecting break-in attempts are generally the most practical means for augmenting basic security. Bells, buzzers, or sirens should be installed to sound an alarm and automatic telephone or wireless dialer should be used to alert a monitoring service to notify the police when an intruder tries to enter the locked building or a security area.

For a large building or a building requiring tight security, defense should be provided in depth. Depending on the value of assets to be protected, protection should start at the boundary of the property, with fences, gates, controlled access, guard patrols, exterior illumination, alarms, or remote surveillance by closed-circuit television. This defense should be backed up by similar measures at the perimeter of the building and by security locks and latches on doors and windows. Openings other than doorways or windows should be barred or made too small for human entry and screened. Within the building, valuables should be housed in locked rooms or a thick, steel safe, with controlled access to those areas.

For most types of occupancy, control at the entrance often may be provided by a receptionist who records names of visitors and persons visited, notifies the latter and can advise the police of disturbances. When necessary, the receptionist can be augmented by a guard at the control point or in a security center and, in very large or high-rise buildings, by a roving guard available for emergencies. If a large security force is needed, facilities should be provided in the building for an office for the security administrator and staff, photographic identification, and squad room and lockers—all in or adjoining a security center.

### **3.7.2 Security Center**

The security center may be equipped with or connected to electronic devices that do the following:

1. Detect a break-in attempt and sound an alarm.
2. Identify the point of intrusion.
3. Turn on lights.
4. Display the intruder on closed-circuit television and record observations on videotape.
5. Notify the police.
6. Limit entry to specific spaces only to approved personnel and only at permitted times.
7. Change locks automatically.

In addition, the center may be provided with emergency reporting systems, security guard tour reporting systems, fire detection and protection systems, including supervision of automatic fire sprinklers, HVAC controls, and supervision of other life safety measures. See also Art. 3.5.12.

(P. S. Hopf, "Handbook of Building Security Planning and Design," McGraw-Hill Publishing Company, New York.)