SECTION ONE

BUILDING SYSTEMS*

Jonathan T. Ricketts
Consulting Engineer
Palm Beach Gardens, Florida

Sociological changes, new technology in industry and commerce, new building codes, other new laws and regulations, inflationary economies of nations, and advances in building technology place an ever-increasing burden on building designers and constructors. They need more and more knowledge and skill to cope with the demands placed on them.

The public continually demands more complex buildings than in the past. They must serve more purposes, last longer, and require less maintenance and repair. As in the past, they must look attractive. Yet, both building construction and operating costs must be kept within acceptable limits or new construction will cease.

To meet this challenge successfully, continual improvements in building design and construction must be made. Building designers and constructors should be alert to these advances and learn how to apply them skillfully.

One advance of note to building design is the adaptation of operations research, or systems design, developed around the middle of the twentieth century and originally applied with noteworthy results to design of machines and electronic equipment. In the past, design of a new building was mainly an imitation of the design of an existing building. Innovations were often developed fortuitously and by intuition and were rare occurrences. In contrast, systems design encourages innovation. It is a precise procedure that guides creativity toward the best decisions. As a result, it can play a significant role in meeting the challenges posed by increasing building complexity and costs. The basic principles of systems design are presented in this section.

1.1 PRINCIPLES OF ARCHITECTURE

A building is an assemblage that is firmly attached to the ground and that provides total or nearly total shelter for machines, processing equipment, performance of human activities, storage of human possessions, or any combination of these.

*Revised and updated from the previous edition by the late Frederick S. Merritt.

Building design is the process of providing all information necessary for construction of a building that will meet its owner's requirements and also satisfy public health, welfare, and safety requirements. **Architecture** is the art and science of building design. **Building construction** is the process of assembling materials to form a building.

Building design may be legally executed only by persons deemed competent to do so by the state in which the building is to be constructed. Competency is determined on the basis of education, experience, and ability to pass a written test of design skills.

Architects are persons legally permitted to practice architecture. **Engineers** are experts in specific scientific disciplines and are legally permitted to design parts of buildings; in some cases, complete buildings. In some states, persons licensed as **building designers** are permitted to design certain types of buildings.

Building construction is generally performed by laborers and craftspeople engaged for the purpose by an individual or organization, called a **contractor**. The contractor signs an agreement, or contract, with the building owner under which the contractor agrees to construct a specific building on a specified site and the owner agrees to pay for the materials and services provided.

In the design of a building, architects should be guided by the following principles:

1. The building should be constructed to serve purposes specified by the client.
2. The design should be constructable by known techniques and with available labor and equipment, within an acceptable time.
3. The building should be capable of withstanding the elements and normal usage for a period of time specified by the client.
4. Both inside and outside, the building should be visually pleasing.
5. No part of the building should pose a hazard to the safety or health of its occupants under normal usage, and the building should provide for safe evacuation or refuge in emergencies.
6. The building should provide the degree of shelter from the elements and of control of the interior environment—air, temperature, humidity, light, and acoustics—specified by the client and not less than the minimums required for safety and health of the occupants.
7. The building should be constructed to minimize adverse impact on the environment.
8. Operation of the building should consume a minimum of energy while permitting the structure to serve its purposes.
9. The sum of costs of construction, operation, maintenance, repair, and anticipated future alterations should be kept within the limit specified by the client.

The ultimate objective of design is to provide all the information necessary for the construction of a building. This objective is achieved by the production of **drawings**, or **plans**, showing what is to be constructed, **specifications** stating what materials and equipment are to be incorporated in the building, and a **construction contract** between the client and a contractor. Designers also should observe construction of the building while it is in process. This should be done not only to assist the client in ensuring that the building is being constructed in accordance with plans and specifications but also to obtain information that will be useful in design of future buildings.

1.2 SYSTEMS DESIGN AND ANALYSIS

Systems design comprises a logical series of steps that leads to the best decision for a given set of conditions. The procedure requires:

Analysis of a building as a system.

Synthesis, or selection of components, to form a system that meets specific objectives while subject to constraints, or variables controllable by designers.

Appraisal of system performance, including comparisons with alternative systems.

Feedback to analysis and synthesis of information obtained in system evaluation, to improve the design.

The prime advantage of the procedure is that, through comparisons of alternatives and data feedback to the design process, systems design converges on an optimum, or best, system for the given conditions. Another advantage is that the procedure enables designers to clarify the requirements for the building being designed. Still another advantage is that the procedure provides a common basis of understanding and promotes cooperation between the specialists in various aspects of building design.

For a building to be treated as a system, as required in systems design, it is necessary to know what a system is and what its basic characteristics are.

A system is an assemblage formed to satisfy specific objectives and subject to constraints and restrictions and consisting of two or more components that are interrelated and compatible, each component being essential to the required performance of the system.

Because the components are required to be interrelated, operation, or even the mere existence, of one component affects in some way the performance of other components. Also, the required performance of the system as a whole, as well as the constraints on the system, imposes restrictions on each component.

A building meets the preceding requirements. By definition, it is an assemblage (Art. 1.1). It is constructed to serve specific purposes. It is subject to constraints while doing so, inasmuch as designers can control properties of the system by selection of components (Art. 1.9). Building components, such as walls, floors, roofs, windows, and doors, are interrelated and compatible with each other. The existence of any of these components affects to some extent the performance of the others. And the required performance of the building as a whole imposes restrictions on the components. Consequently, a building has the basic characteristics of a system, and systems-design procedures should be applicable to it.

Systems Analysis. A group of components of a system may also be a system. Such a group is called a **subsystem**. It, too, may be designed as a system, but its goal must be to assist the system of which it is a component to meet its objectives. Similarly, a group of components of a subsystem may also be a system. That group is called a **subsubsystem**.

For brevity, the major subsystems of a building are referred to as systems in this book.

In a complex system, such as a building, subsystems and other components may be combined in a variety of ways to form different systems. For the purposes of building design, the major systems are usually defined in accordance with the construction trades that will assemble them, for example, structural framing, plumbing, electrical systems, and heating, ventilation, and air conditioning.

In systems analysis, a system is resolved into its basic components. Subsystems are determined. Then, the system is investigated to determine the nature, interaction,

and performance of the system as a whole. The investigation should answer such questions as:

What does each component (or subsystem) do?

What does the component do it to?

How does the component serve its function?

What else does the component do?

Why does the component do the things it does?

What must the component really do?

Can it be eliminated because it is not essential or because another component can assume its tasks?

See also Art. 1.8.

1.3 TRADITIONAL DESIGN PROCEDURES

Systems design of buildings requires a different approach to design and construction than that used in traditional design (Art. 1.9). Because traditional design and construction procedures are still widely used, however, it is desirable to incorporate as much of those procedures in systems design as is feasible without destroying its effectiveness. This will make the transition from traditional design to systems design easier. Also, those trained in systems design of buildings will then be capable of practicing in traditional ways, if necessary.

There are several variations of traditional design and construction. These are described throughout this book. For the purpose of illustrating how they may be modified for systems design, however, one widely used variation, which will be called basic traditional design and construction, is described in the following and in Art. 1.4.

In the basic traditional design procedure, design usually starts when a client recognizes the need for and economic feasibility of a building and engages an architect, a professional with a broad background in building design. The architect, in turn, engages consulting engineers and other consultants.

For most buildings, structural, mechanical, and electrical consulting engineers are required. A structural engineer is a specialist trained in the application of scientific principles to the design of load-bearing walls, floors, roofs, foundations, and skeleton framing needed for the support of buildings and building components. A mechanical engineer is a specialist trained in the application of scientific principles to the design of plumbing, elevators, escalators, horizontal walkways, dumbwaiters, conveyors, installed machinery, and heating, ventilation, and air conditioning. An electrical engineer is a specialist trained in the application of scientific principles to the design of electric circuits, electric controls and safety devices, electric motors and generators, electric lighting, and other electric equipment.

For buildings on a large site, the architect may engage a landscape architect as a consultant. For a concert hall, an acoustics consultant may be engaged; for a hospital, a hospital specialist; for a school, a school specialist.

The architect does the overall planning of the building and incorporates the output of the consultants into the contract documents. The architect determines what internal and external spaces the client needs, the sizes of these spaces, their relative

locations, and their interconnections. The results of this planning are shown in floor plans, which also diagram the internal flow, or circulation, of people and supplies. Major responsibilities of the architect are enhancement of the appearance inside and outside of the building and keeping adverse environmental impact of the structure to a minimum. The exterior of the building is shown in drawings, called elevations. The location and orientation of the building is shown in a site plan. The architect also prepares the specifications for the building. These describe in detail the materials and equipment to be installed in the structure. In addition, the architect, usually with the aid of an attorney engaged by the client, prepares the construction contract.

The basic traditional design procedure is executed in several stages. In the first stage, the architect develops a **program**, or list of the client's requirements. In the next stage, **the schematic or conceptual phase**, the architect translates requirements into spaces, relates the spaces and makes sketches, called schematics, to illustrate the concepts. When sufficient information is obtained on the size and general construction of the building, a rough estimate is made of construction cost. If this cost does not exceed the cost budgeted by the client for construction, the next stage, **design development**, proceeds. In this stage, the architect and consultants work out more details and show the results in preliminary construction drawings and outline specifications. A preliminary cost estimate utilizing the greater amount of information on the building now available is then prepared. If this cost does not exceed the client's budget, the final stage, the **contract documents phase**, starts. It culminates in production of working, or construction, drawings and specifications, which are incorporated in the contract between the client and a builder and therefore become legal documents. Before the documents are completed, however, a final cost estimate is prepared. If the cost exceeds the client's budget, the design is revised to achieve the necessary cost reduction.

In the traditional design procedure, after the estimated cost is brought within the budget and the client has approved the contract documents, the architect helps the owner in obtaining bids from contractors or in negotiating a construction price with a qualified contractor. For private work, construction not performed for a governmental agency, the owner generally awards the construction contract to a contractor, called a **general contractor**. Assigned the responsibility for construction of the building, this contractor may perform some, all, or none of the work. Usually, much of the work is let out to specialists, called **subcontractors**. For public work, there may be a legal requirement that bids be taken and the contract awarded to the lowest responsible bidder. Sometimes also, separate contracts have to be awarded for the major specialists, such as mechanical and electrical trades, and to a general contractor, who is assigned responsibility for coordinating the work of the trades and performance of the work. (See also Art. 1.4.)

Building design should provide for both normal and emergency conditions. The latter includes fire, explosion, power cutoffs, hurricanes, and earthquakes. The design should include access and facilities for disabled persons.

1.4 TRADITIONAL CONSTRUCTION PROCEDURES

As mentioned in Art. 1.3, construction under the traditional construction procedure is performed by contractors. While they would like to satisfy the owner and the

building designers, contractors have the main objective of making a profit. Hence, their initial task is to prepare a bid price based on an accurate estimate of construction costs. This requires development of a concept for performance of the work and a construction time schedule. After a contract has been awarded, contractors must furnish and pay for all materials, equipment, power, labor, and supervision required for construction. The owner compensates the contractors for construction costs and services.

A **general contractor** assumes overall responsibility for construction of a building. The contractor engages **subcontractors** who take responsibility for the work of the various trades required for construction. For example, a plumbing contractor installs the plumbing, an electrical contractor installs the electrical system, a steel erector structural steel, and an elevator contractor installs elevators. Their contracts are with the general contractor, and they are paid by the general contractor.

Sometimes, in addition to a general contractor, the owners contracts separately with specialty contractors, such as electrical and mechanical contractors, who perform a substantial amount of the work required for a building. Such contractors are called **prime contractors**. Their work is scheduled and coordinated by the general contractor, but they are paid directly by the owner.

Sometimes also, the owner may use the design-build method and award a contract to an organization for both the design and construction of a building. Such organizations are called **design-build contractors**. One variation of this type of contract is employed by developers of groups of one-family homes or low-rise apartment buildings. The **homebuilder** designs and constructs the dwellings, but the design is substantially completed before owners purchase the homes.

Administration of the construction procedure often is difficult. Consequently, some owners seek assistance from an expert, called a **professional construction manager**, with extensive construction experience, who receives a fee. The construction manager negotiates with general contractors and helps select one to construct the building. Managers usually also supervise selection of subcontractors. During construction, they help control costs, expedite equipment and material deliveries, and keep the work on schedule (see Art. 17.9). In some cases, instead, the owner may prefer to engage a **construction program manager**, to assist in administering both design and construction.

Construction contractors employ labor that may or may not be unionized. Unionized craftspeople are members of unions that are organized by construction trades, such as carpenter, plumber, and electrician unions. Union members will perform only the work assigned to their trade. On the job, groups of workers are supervised by **crew supervisors**, all of whom report to a **superintendent**.

During construction, all work should be inspected. For this purpose, the owner, often through the architect and consultants, engages inspectors. The field inspectors may be placed under the control of an owner's representative, who may be titled *clerk of the works*, *architect's superintendent*, *engineer's superintendent*, or *resident engineer*. The inspectors have the responsibility of ensuring that construction meets the requirements of the contract documents and is performed under safe conditions. Such inspections may be made at frequent intervals.

In addition, inspections also are made by representatives of one or more governmental agencies. They have the responsibility of ensuring that construction meets legal requirements and have little or no concern with detailed conformance with the contract documents. Such legal inspections are made periodically or at the end of certain stages of construction. One agency that will make frequent inspections is the local or state building department, whichever has jurisdiction. The purpose of these inspections is to ensure conformance with the local or state building code.

During construction, standards, regulations, and procedures of the Occupational Safety and Health Administration should be observed. These are given in detail in "Construction Industry. OSHA Safety and Health Standards (29CFR1926/1910)," Government Printing Office, Washington, DC 20402.

Following is a description of the basic traditional construction procedure for a multistory building:

After the award of a construction contract to a general contractor, the owner may ask the contractor to start a portion of the work before signing of the contract by giving the contractor a *letter of intent* or after signing of the contract by issuing a *written notice to proceed*. The contractor then obtains construction permits, as required, from governmental agencies, such as the local building, water, sewer, and highway departments.

The general contractor plans and schedules construction operations in detail and mobilizes equipment and personnel for the project. Subcontractors are notified of the contract award and issued letters of intent or awarded subcontracts, then are given, at appropriate times, notices to proceed.

Before construction starts, the general contractor orders a survey to be made of adjacent structures and terrain, both for the record and to become knowledgeable of local conditions. A survey is then made to lay out construction.

Field offices for the contractor are erected on or near the site. If desirable for safety reasons to protect passersby, the contractor erects a fence around the site and an overhead protective cover, called a bridge. Structures required to be removed from the site are demolished and the debris is carted away.

Next, the site is prepared to receive the building. This work may involve grading the top surface to bring it to the proper elevations, excavating to required depths for basement and foundations, and shifting of utility piping. For deep excavations, earth sides are braced and the bottom is drained.

Major construction starts with the placement of foundations, on which the building rests. This is followed by the erection of load-bearing walls and structural framing. Depending on the height of the building, ladders, stairs, or elevators may be installed to enable construction personnel to travel from floor to floor and eventually to the roof. Also, hoists may be installed to lift materials to upper levels. If needed, temporary flooring may be placed for use of personnel.

As the building rises, pipes, ducts, and electric conduit and wiring are installed. Then, permanent floors, exterior walls, and windows are constructed. At the appropriate time, permanent elevators are installed. If required, fireproofing is placed for steel framing. Next, fixed partitions are built and the roof and its covering, or roofing, are put in place.

Finishing operations follow. These include installation of the following: ceilings; tile; wallboard; wall paneling; plumbing fixtures; heating furnaces; air-conditioning equipment; heating and cooling devices for rooms; escalators; floor coverings; window glass; movable partitions; doors; finishing hardware; electrical equipment and apparatus, including lighting fixtures, switches, outlets, transformers, and controls; and other items called for in the drawings and specifications. Field offices, fences, bridges, and other temporary construction must be removed from the site. Utilities, such as gas, electricity, and water, are hooked up to the building. The site is landscaped and paved. Finally, the building interior is painted and cleaned.

The owner's representatives then give the building a final inspection. If they find that the structure conforms with the contract documents, the owner accepts the project and gives the general contractor final payment on issuance by the building department of a certificate of occupancy, which indicates that the completed building meets building-code requirements.

1.5 **ROLE OF THE CLIENT IN DESIGN AND CONSTRUCTION**

Article 1.4 points out that administration of building construction is difficult, as a result of which some clients, or owners, engage a construction manager or construction program manager to act as the owner's authorizing agent and project overseer. The reasons for the complexity of construction administration can be seen from an examination of the owner's role before and during construction.

After the owner recognizes the need for a new building, the owner establishes project goals and determines the economic feasibility of the project. If it appears to be feasible, the owner develops a building program (list of requirements), budget, and time schedule for construction. Next, preliminary arrangements are made to finance construction. Then, the owner selects a construction program manager or an architect for design of the building. Later, a construction manager may be chosen, if desired.

The architect may seek from the owner approval of the various consultants that will be needed for design. If a site for the building has not been obtained at this stage, the architect can assist in site selection. When a suitable site has been found, the owner purchases it and arranges for surveys and subsurface explorations to provide information for locating the building, access, foundation design and construction, and landscaping. It is advisable at this stage for the owner to start developing harmonious relations with the community in which the building will be erected.

During design, the owner assists with critical design decisions; approves schematic drawings, rough cost estimates, preliminary drawings, outline specifications, preliminary cost estimates, contract documents, and final cost estimate; pays designers' fees in installments as design progresses; and obtains a construction loan. Then, the owner awards the general contract for construction and orders construction to start. Also, the owner takes out liability, property, and other desirable insurance.

At the start of construction, the owner arranges for construction permits. As construction proceeds, the owner's representatives inspect the work to ensure compliance with the contract documents. Also, the owner pays contractors in accordance with the terms of the contract. Finally, the owner approves and accepts the completed project.

One variation of the preceding procedure is useful when time available for construction is short. It is called **phase, or fast-track, construction**. In this variation, the owner engages a construction manager and a general contractor before design has been completed, to get an early start on construction. Work then proceeds on some parts of the building while other parts are still being designed. For example, excavation and foundation construction are carried out while design of the structural framing is being finished. The structural framing is erected, while heating, ventilation, and air-conditioning, electrical, plumbing, wall, and finishing details are being developed. For tall buildings, the lower portion can be constructed while the upper part is still being designed. For large, low-rise buildings, one section can be built while another is under design.

1.6 **BUILDING COSTS**

Construction cost of a building usually is a dominant design concern. One reason is that if construction cost exceeds the owner's budget, the owner may cancel the

project. Another reason is that costs, such as property taxes and insurance, that occur after completion of the building often are proportional to the initial cost. Hence, owners usually try to keep that cost low. Designing a building to minimize construction cost, however, may not be in the owner's best interests. There are many other costs that the owner incurs during the anticipated life of the building that should be taken into account.

Before construction of a building starts, the owner generally has to make a sizable investment in the project. The major portion of this expenditure usually goes for purchase of the site and building design. Remaining preconstruction costs include those for feasibility studies, site selection and evaluation, surveys, and program definition.

The major portion of the construction cost is the sum of the payments to the general contractor and prime contractors. Remaining construction costs usually consist of interest on the construction loan, permit fees, and costs of materials, equipment, and labor not covered by the construction contracts.

The **initial cost** to the owner is the sum of preconstruction, construction, and occupancy costs. The latter covers costs of moving possessions into the building and start-up of utility services, such as water, gas, electricity, and telephone.

After the building is occupied, the owner incurs costs for operation and maintenance of the buildings. Such costs are a consequence of decisions made during building design.

Often, preconstruction costs are permitted to be high so that initial costs can be kept low. For example, operating the building may be expensive because the design makes artificial lighting necessary when daylight could have been made available or because extra heating and air conditioning are necessary because of inadequate insulation of walls and roof. As another example, maintenance may be expensive because of the difficulty of changing electric lamps or because cleaning the building is time-consuming and laborious. In addition, frequent repairs may be needed because of poor choice of materials during design. Hence, operation and maintenance costs over a specific period of time, say 10 or 20 years, should be taken into account in optimizing the design of a building.

Life-cycle cost is the sum of initial, operating, and maintenance costs. Generally, it is life-cycle cost that should be minimized in building design rather than construction cost. This would enable the owner to receive the greatest return on the investment in the building. ASTM has promulgated a standard method for calculating life-cycle costs of buildings, E917, Practice for Measuring Life-Cycle Costs of Buildings and Building Systems, as well as a computer program and user's guide to improve accuracy and speed of calculation.

Nevertheless, a client usually establishes a construction budget independent of life-cycle cost. This often is necessary because the client does not have adequate capital for an optimum building and places too low a limit on construction cost. The client hopes to have sufficient capital later to pay for the higher operating and maintenance costs or for replacement of undesirable building materials and installed equipment. Sometimes, the client establishes a low construction budget because the client's goal is a quick profit on early sale of the building, in which case the client has little or no concern with future high operating and maintenance costs for the building. For these reasons, construction cost frequently is a dominant concern in design.

1.7 MAJOR BUILDING SYSTEMS

The simplest building system consists of only two components. One component is a floor, a flat, horizontal surface on which human activities can take place. The

other component is an enclosure that extends over the floor and generally also around it to provide shelter from the weather for human activities.

The ground may serve as the floor in primitive buildings. In better buildings, however, the floor may be a structural deck laid on the ground or supported above ground on structural members, such as the joist and walls in Fig. 1.1. Use of a deck and structural members adds at least two different types of components, or two subsystems, to the simplest building system. Also, often, the enclosure over the floor requires supports, such as the rafter and walls in Fig. 1.1, and the walls, in turn, are seated on foundations in the ground. Additionally, **footings** are required at the base of the foundations to spread the load over a large area of the ground, to prevent the building from sinking (Fig. 1.2a). Consequently, even slight improvements in a primitive building introduce numerous additional components, or subsystems, into a building.

More advanced buildings consist of numerous subsystems, which are referred to as systems in this book when they are major components. Major subsystems generally include structural framing and foundations, enclosure systems, plumbing, lighting, acoustics, safety systems, vertical-circulation elements, electric power and signal systems, and heating, ventilation, and air conditioning (HVAC).

Structural System. The portion of a building that extends above the ground level outside it is called the **superstructure**. The portion below the outside ground level is called the **substructure**. The parts of the substructure that distribute building loads to the ground are known as **foundations**.

Foundations may take the form of walls. When the ground under the building is excavated for a cellar, or basement, the foundation walls have the additional task of retaining the earth along the outside of the building (Fig. 1.1). The superstructure in such cases is erected atop the foundation walls.

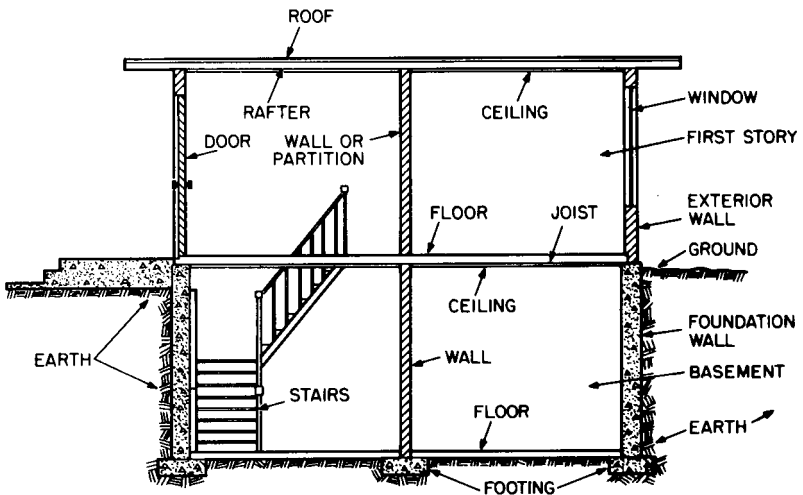

FIGURE 1.1 Vertical section through a one-story building with basement shows location of some major components. (Reprinted with permission from F. S. Merritt and J. Ambrose, "Building Engineering and Systems Design," 2d ed., Van Nostrand Reinhold, New York.)

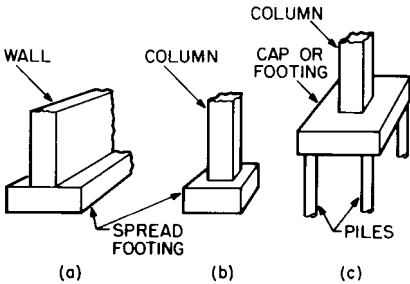

FIGURE 1.2 Commonly used foundations: (a) foundation wall on continuous footing; (b) individual spread footing for a column; (c) pile footing for a column.

hammered or otherwise driven through the weak soil, often until the tips seat on rock or a strong layer of soil.

The foundation system must be designed to transmit the loads from the superstructure structural system directly to the ground in such a manner that settlement of the completed building as the soil deflects will be within acceptable limits. The superstructure structural system, in turn, should be designed to transmit its loads to the foundation system in the manner anticipated in the design of the foundations. (See also Sec. 6.)

In most buildings, the superstructure structural system consists of floor and roof decks, horizontal members that support them, and vertical members that support the other components.

The horizontal members are generally known as **beams**, but they also are called by different names in specific applications. For example:

Joists are closely spaced to carry light loads.

Stringers support stairs.

Headers support structural members around openings in floors, roofs, and walls.

Purlins are placed horizontally to carry level roof decks.

Rafters are placed on an incline to carry sloping roof decks.

Girts are light horizontal members that span between columns to support walls.

Lintels are light horizontal beams that support walls at floor levels in multistory buildings or that carry the part of walls above openings for doors and windows.

Girders may be heavily loaded beams or horizontal members that support other beams (Fig. 1.3).

Spandrels carry exterior walls and support edges of floors and roofs in multi-story buildings.

Trusses serve the same purposes as girders but consists of slender horizontal, vertical, and inclined components with large open spaces between them. The spaces are triangular in shape. Light beams similarly formed are called **open-web joists** (Fig. 1.6d).

Floor and roof decks or the beams that support them are usually seated on load-bearing walls or carried by columns, which carry the load downward. (The horizontal members also may be suspended on hangers, which transmit the load to

The footing under a wall (Fig. 1.2a) is called a **continuous spread footing**. A slender structural member, such as a column (Fig. 1.2b), usually is seated on an **individual spread footing**. When the soil is so weak, however, that the spread footings for columns become very large, it often is economical to combine the footings into a single footing under the whole building. Such a footing is called a **raft**, or **mat**, **footing** or a **floating foundation**. For very weak soils, it generally is necessary to support the foundations on **piles** (Fig. 1.2c). These are slender structural members that are

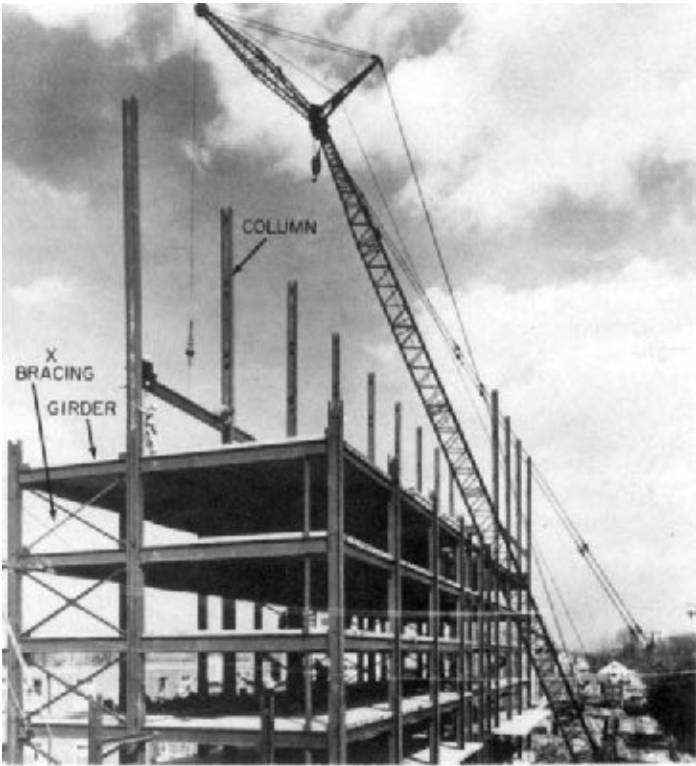

FIGURE 1.3 Structural-steel skeleton framing for a multistory building. (Courtesy of the American Institute of Steel Construction.)

other horizontal members at a higher level.) The system comprising decks, beams, and bearing walls is known as load-bearing construction (Fig. 1.1). The system composed of decks, beams, and columns is known as skeleton framing (Fig. 1.3).

Both types of systems must be designed to transmit to the foundations vertical (gravity) loads, vertical components of inclined loads, horizontal (lateral) loads, and horizontal components of inclined loads. Vertical walls and columns have the appropriate alignments for carrying vertical loads downward. But acting alone, these structural members are inadequate for resisting lateral forces.

One way to provide lateral stability is to incorporate in the system diagonal members, called **bracing** (Fig. 1.3). Bracing, columns, and beams then work together to carry the lateral loads downward. Another way is to rigidly connect beams to columns to prevent a change in the angle between the beams and columns, thus making them work together as a **rigid frame** to resist lateral movement. Still another way is to provide long walls, known as **shear walls**, in two perpendicular directions. Lateral forces on the building can be resolved into forces in each of these directions. The walls then act like vertical beams (**cantilevers**) in transmitting the forces to the foundations. (See also Art. 3.2.4.)

Because of the importance of the structural system, the structural members should be protected against damage, especially from fire. For fire protection, bracing

may be encased in fire-resistant floors, roofs, or walls. Similarly, columns may be encased in walls, and beams may be encased in floors. Or a fire-resistant material, such as concrete, mineral fiber, or plaster, may be used to box in the structural members (Fig. 1.6c).

See also Secs. 7 to 11.

Systems for Enclosing Buildings. Buildings are enclosed for privacy, to exclude wind, rain, and snow from the interior, and to control interior temperature and humidity. A single-enclosure type of system is one that extends continuously from the ground to enclose the floor. Simple examples are cone-like tepees and dome igloos. A multiple-enclosure type of system consists of a horizontal or inclined top covering, called a **roof** (Fig. 1.1), and vertical or inclined side enclosures called **walls**.

Roofs may have any of a wide variety of shapes. A specific shape may be selected because of appearance, need for attic space under the roof, requirements for height between roof and floor below, desire for minimum enclosed volume, structural economy, or requirements for drainage of rainwater and shedding of snow. While roofs are sometimes given curved surfaces, more often roofs are composed of one or more plane surfaces. Some commonly used types are shown in Fig. 1.4.

The flat roof shown in Fig. 1.4a is nearly horizontal but has a slight pitch for drainage purposes. A more sloped roof is called a shed roof (Fig. 1.4b). A pitched roof (Fig. 1.4c) is formed by a combination of two inclined planes. Four inclined planes may be combined to form either a hipped roof (Fig. 1.4d) or a gambrel roof (Fig. 1.4e). A mansard roof (Fig. 1.4f) is similar to a hipped roof but, composed of additional planes, encloses a larger volume underneath. Any of the preceding roofs may have glazed openings, called **skylights** (Fig. 1.4b), for daylighting the building interior. The roofs shown in Fig. 1.4c to f are often used to enclose attic space. Windows may be set in **dormers** that project from a sloped roof (Fig. 1.4c). Other alternatives, often used to provide large areas free of walls or columns, include flat-plate and arched or dome roofs.

Monitored roofs are sometimes used for daylighting and ventilating the interior. A **monitor** is a row of windows installed vertically, or nearly so, above a roof (Fig.

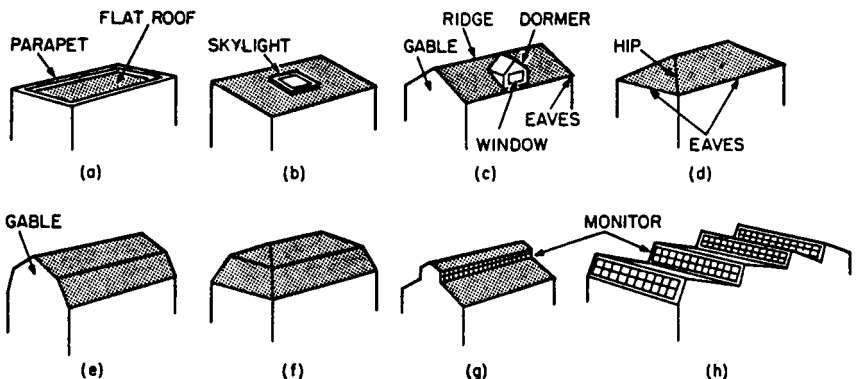

FIGURE 1.4 Roofs composed of plane surfaces: (a) flat roof; (b) shed roof; (c) pitched roof; (d) hipped roof; (e) gambrel roof; (f) mansard roof; (g) monitored roof; (h) sawtooth roof. (Reprinted with permission from F. S. Merritt and J. Ambrose, "Building Engineering and Systems Design," 2d ed., Van Nostrand Reinhold, New York.)

1.4g). Figure 1.4h illustrates a variation of a monitored roof that is called a sawtooth roof.

The basic element in a roof is a thin, waterproof covering, called **roofing** (Sec. 12). Because it is thin, it is usually supported on **sheathing**, a thin layer, or **roof deck**, a thick layer, which in turn, is carried on structural members, such as beams or trusses. The roof or space below should contain thermal insulation (Fig. 1.6c and d).

Exterior walls enclose a building below the roof. The basis element in the walls is a strong, durable, water-resistant facing. For added strength or lateral stability, this facing may be supplemented on the inner side by a backing or sheathing (Fig. 1.5b). For esthetic purposes, an interior facing usually is placed on the inner side of the backing. A layer of insulation should be incorporated in walls to resist passage of heat.

Generally, walls may be built of unit masonry, panels, framing, or a combination of these materials.

Unit masonry consists of small units, such as clay brick, concrete block, glass block, or clay tile, held together by a cement such as mortar. Figure 1.5a shows a wall built of concrete blocks.

Panel walls consist of units much larger than unit masonry. Made of metal, concrete, glass, plastics, or preassembled bricks, a panel may extend from foun-

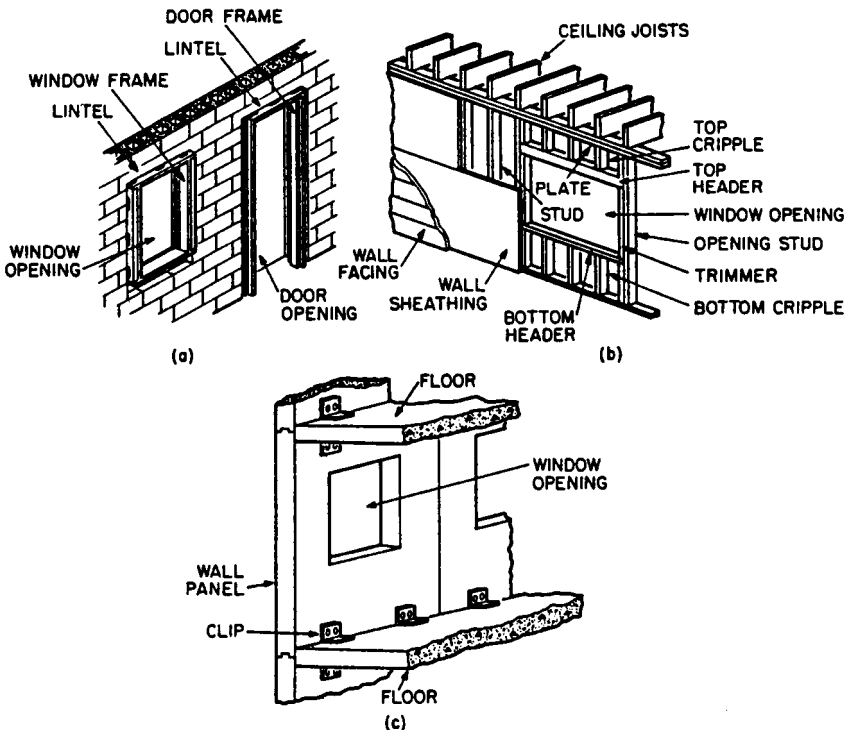

FIGURE 1.5 Types of exterior wall construction: (a) concrete-block wall; (b) wood-framed wall; (c) precast-concrete curtain wall.

dition to roof in single-story buildings, or from floor to floor or from window header in one story to window sill of floor above in multistory buildings. Large panels may incorporate one or more windows. Figure 1.5c shows a concrete panel with a window.

Framed walls consist of slender, vertical, closely spaced structural members, tied together with horizontal members at top and bottom, and interior and exterior facings. Thermal insulation may be placed between the components. Figure 1.5b shows a wood-framed exterior wall.

Combination walls are constructed of several different materials. Metal, brick, concrete, or clay tile may be used as the exterior facing because of strength, durability, and water and fire resistance. These materials, however, are relatively expensive. Consequently, the exterior facing is made thin and backed up with a less expensive material. For example, brick may be used as an exterior facing with wood framing or concrete block as the backup.

Exterior walls may be classified as curtain walls or bearing walls. **Curtain walls** serve primarily as an enclosure. Supported by the structural system, such walls need to be strong enough to carry only their own weight and wind pressure on the exterior face. **Bearing walls**, in contrast, serve not only as an enclosure but also to transmit to the foundation loads from other building components, such as beams, floors, roofs, and other walls (Fig. 1.5a and b). (See also Sec. 11.)

Openings are provided in exterior walls for a variety of purposes, but mainly for windows and doors. Where openings occur, structural support must be provided over them to carry the weight of the wall above and any other loads on that portion of the wall. Usually, a beam called a lintel is placed over openings in masonry walls (Fig. 1.5a) and a beam called a top header is set over openings in wood-framed walls.

A **window** usually consists of transparent glass or plastics (**glazing**) held in place by light framing, called **sash**. The window is fitted into a frame secured to the walls (Fig. 1.5a). For sliding windows, the frame carries guides in which the sash slides. For swinging windows, stops against which the window closes are built into the frame.

Hardware is provided to enable the window to function as required. For movable windows, the hardware includes grips for moving them, locks, hinges for swinging windows, and sash balances and pulleys for vertically sliding windows.

The main purposes of windows are to illuminate the building interior with daylight, to ventilate the interior, and to give occupants a view of the outside. For retail stores, windows may have the major purpose of giving passersby a view of items displayed inside. (See also Sec. 11.)

Doors are installed in exterior walls to give access to or from the interior or to prevent such access. For similar reasons, doors are also provided in interior walls and partitions. Thus, a door may be part of a system for enclosing a building or a component of a system for enclosing interior spaces.

Systems for Enclosing Interior Spaces. The interior of a building usually is compartmented into spaces or rooms by horizontal dividers (floor-ceiling or roof-ceiling systems) and vertical dividers (interior walls and partitions). (The term partitions is generally applied to non-load-bearing walls.)

Floor-Ceiling Systems. The basic element of a floor is a load-carrying deck. For protection against wear, esthetic reasons, foot comfort, or noise control, a **floor covering** often is placed over the deck, which then may be referred to as a **subfloor**. Figure 1.6a shows a concrete subfloor with a flexible-tile floor covering. A hollow-cold-formed steel deck is incorporated in the subfloor to house electric wiring.

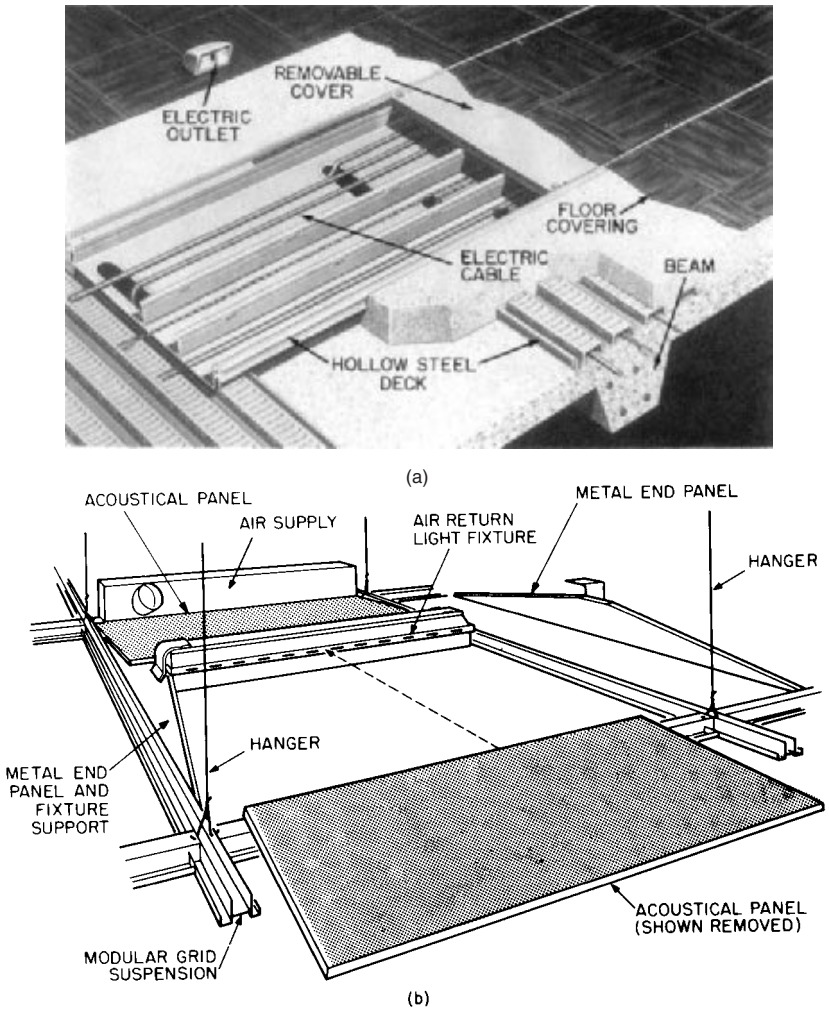

FIGURE 1.6 Examples of floor-ceiling and roof-ceiling systems. (a) Concrete structural slab carries hollow-steel deck, concrete fill, and flexible tile flooring. (b) Acoustical-tile ceiling incorporating a lighting fixture with provisions for air distribution is suspended below a floor. (c) Insulated roof and steel beams are sprayed with mineral fiber for fire protection. (d) Insulated roof and open-web joists are protected by a fire-rated suspended ceiling.

In some cases, a subfloor may be strong and stiff enough to span, unaided, long distances between supports provided for it. In other cases, the subfloor is closely supported on beams. The subfloor in Fig. 1.6a, for example, is shown constructed integrally with concrete beams, which carry the loads from the subfloor to bearing walls or columns.

The underside of a floor or roof and of beams supporting it, including decorative treatment when applied to that side, is called a **ceiling**. Often, however, a separate

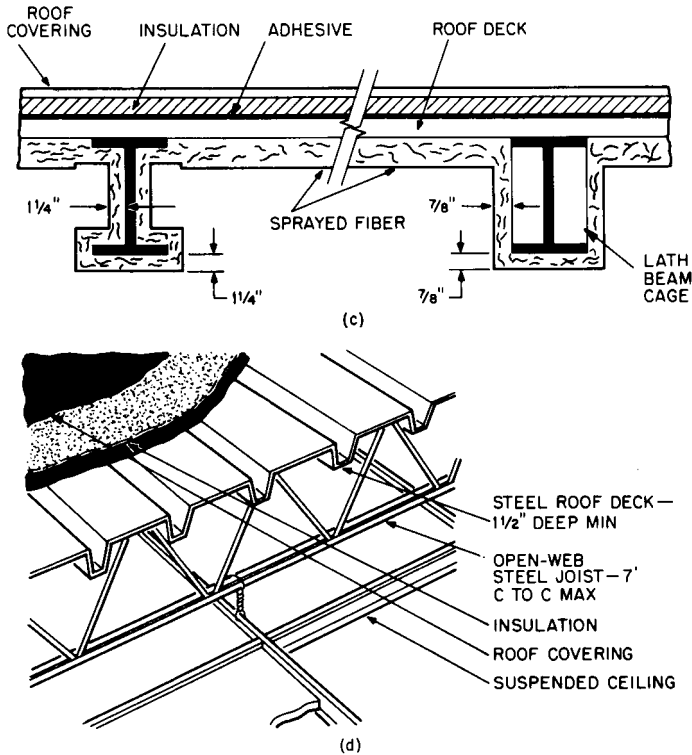

FIGURE 1.6 (Continued)

ceiling is suspended below a floor or roof for esthetic or other reasons. Figure 1.6*b* shows such a ceiling. It is formed with acoustical panels and incorporates a lighting fixture and air-conditioning inlets and outlets.

Metal and wood subfloors and beams require fire protection. Figure 1.6*c* shows a roof and its steel beams protected on the underside by a sprayed-on mineral fiber. Figure 1.6*d* shows a roof and open-web steel joists protected on the underside by a continuous, suspended, fire-resistant ceiling. As an alternative to encasement in or shielding by a fire-resistant material, wood may be made fire-resistant by treatment with a fire-retardant chemical.

Fire Ratings. Tests have been made, usually in conformance with E119, "Standard Methods of Tests of Building Construction and Materials," developed by ASTM, to determine the length of time specific assemblies of materials can withstand a standard fire, specified in E119. On the basis of test results, each construction is assigned a fire rating, which gives the time in hours that the assembly can withstand the fire. Fire ratings for various types of construction may be obtained from local, state, or model building codes or the "Fire Resistance Design Manual," published by the Gypsum Association.

Interior Walls and Partitions. Interior space dividers do not have to withstand such severe conditions as do exterior walls. For instance, they are not exposed to rain, snow, and solar radiation. Bearing walls, however, must be strong enough to

transmit to supports below them the loads to which they are subjected. Usually, such interior walls extend vertically from the roof to the foundations of a building and carry floors and roof. The basic element of a bearing wall may be a solid core, as shown in Fig. 1.7*d*, or closely spaced vertical framing (**studs**), as shown in Fig. 1.7*b*.

Non-load-bearing partitions do not support floors or roof. Hence, partitions may be made of such thin materials as sheet metal (Fig. 1.7*a*), brittle materials as glass (Fig. 1.7*a*), or weak materials as gypsum (Fig. 1.7*c*). Light framing may be used to hold these materials in place. Because they are non-load-bearing, partitions may be built and installed to be easily shifted or to be foldable, like a horizontally sliding door. (see also Sec. 11.)

Wall Finishes. Walls are usually given a facing that meets specific architectural requirements for the spaces enclosed. Such requirements include durability under indoor conditions, ease of maintenance, attractive appearance, fire resistance, water resistance, and acoustic properties appropriate to the occupancy of the space enclosed. The finish may be the treated surface of the exposed wall material, such as the smooth, painted face of a sheet-metal panel, or a separate material, such as plaster, gypsumboard, plywood, or wallpaper. (See also Sec. 11.)

Doors. Openings are provided in interior walls and partitions to permit passage of people and equipment from one space to another. Doors are installed in the openings to provide privacy, temperature, odor and sound control, and control passage.

Usually, a door frame is set around the perimeter of the opening to hold the door in place (Fig. 1.8). Depending on the purpose of the door, size, and other factors, the door may be hinged to the frame at top, bottom, or either side. Or the door may be constructed to slide vertically or horizontally or to rotate about a vertical axis in the center of the opening (revolving door). (See also Sec. 11.)

Hardware is provided to enable the door to function as required. For example, hinges are provided for swinging doors, and guides are installed for sliding doors. Locks or latches are placed in or on doors to prevent them from being opened. Knobs or pulls are attached to doors for hand control.

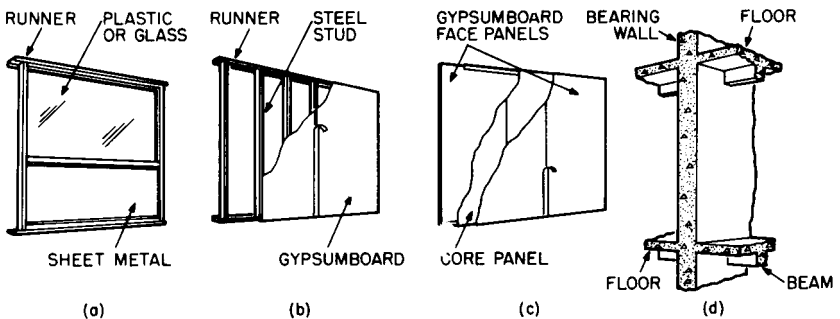

FIGURE 1.7 Types of partitions: (a) non-load-bearing; (b) gypsumboard on metal studs; (c) gypsumboard face panels laminated to a gypsum core panel; (d) concrete bearing wall, floors, and beams. (Reprinted with permission from F. S. Merritt and J. Ambrose, "Building Engineering and Systems Design," 2d ed., Van Nostrand Reinhold, New York.)

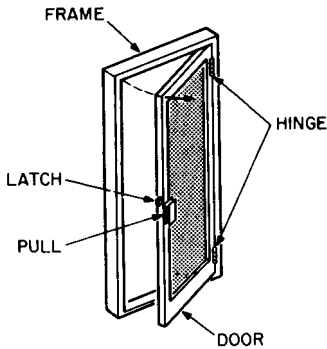

FIGURE 1.8 Example of door and frame.

For health, safety, and other reasons, pipes of different types of plumbing systems must not be interconnected, and care must be taken to prevent flow from one system to another.

The major purposes of plumbing are: (1) to convey water and heating gas, if desired, from sources outside a building to points inside where the fluid or gas is needed, and (2) to collect wastewater and storm water in the building, on the roof, or elsewhere on the site and convey the liquid to sewers outside the building.

For these purposes, plumbing requires fixtures for collecting discharged water and wastes; pipes for supply and disposal; valves for controlling flow; drains, and other accessories. For more details, see Sec. 14.

Heating, Ventilation, and Air-Conditioning (HVAC). Part of the environmental control systems within buildings, along with lighting and sound control, HVAC is often necessary for the health and comfort of building occupants. Sometimes, however, HVAC may be needed for manufacturing processes, product storage, or operation of equipment, such as computers. HVAC usually is used to control temperature, humidity, air movement, and air quality in the interior of buildings.

Ventilation is required to supply clean air for breathing, to furnish air for operation of combustion equipment, and to remove contaminated air. Ventilation, however, also can be used for temperature control by bringing outside air into a building when there is a desirable temperature difference between that air and the interior air.

The simplest way to ventilate is to open windows. When this is not practicable, mechanical ventilation is necessary. This method employs fans to draw outside air into the building and distribute the air, often through ducts, to interior spaces. The method, however, can usually be used only in mild weather. To maintain comfort conditions in the interior, the fresh air may have to be heated in cold weather and cooled in hot weather.

Heating and cooling of a building interior may be accomplished in any of a multitude of ways. Various methods are described in Sec. 13.

Lighting. For health, safety, and comfort of occupants, a building interior should be provided with an adequate quantity of light, good quality of illumination, and proper color of light. The required illumination may be supplied by natural or artificial means.

Builder's Hardware. This is a general term applied to fastenings and devices, such as nails, screws, locks, hinges, and pulleys. These items generally are classified as either finishing hardware or rough hardware (Sec. 11).

Plumbing. The major systems for conveyance of liquids and gases in pipes within a building are classified as plumbing. Plumbing pipes usually are connected to others that extend outside the building to a supply source, such as a public water main or utility gas main, or to a disposal means, such as a sewer.

Daylight is the source of natural illumination. It enters a building through a fenestration, such as windows in the exterior walls or monitors or skylights on the roof.

Artificial illumination can be obtained through consumption of electrical energy in incandescent, fluorescent, electroluminescent, or other electric lamps. The light source is housed in a **luminaire**, or **lighting fixture**. More details are given in Sec. 15.

Acoustics. The science of sound, its production, transmission, and effects are applied in the building design for sound and vibration control.

A major objective of acoustics is provision of an environment that enhances communication in the building interior, whether the sound is created by speech or music. This is accomplished by installation of enclosures with appropriate acoustic properties around sound sources and receivers. Another important objective is reduction or elimination of noise—unwanted sound—from building interiors. This may be accomplished by elimination of the noise at the source, by installation of sound barriers, or by placing sound-absorbing materials on the surfaces of enclosures.

Still another objective is reduction or elimination of vibrations that can annoy occupants, produce noise by rattling loose objects, or crack or break parts or contents of a building. The most effective means of preventing undesirable vibrations is correction of the source. Otherwise, the source should be isolated from the building structure and potential transmission paths should be interrupted with carefully designed discontinuities.

Electric Power and Communication Systems. Electric power is generally bought from nearby utility and often supplemented for emergency purposes by power from batteries or a generating plant on the site. Purchased power is brought from the power lines connected to the generating source to an entrance control point and a meter in the building. From there, conductors distribute the electricity throughout the building to outlets where the power can be tapped for lighting, heating, and operating electric devices.

Two interrelated types of electrical systems are usually provided within a building. One type is used for communications, including data, telephone, television, background music, paging, signal and alarm systems. The second type serves the other electrical needs of the building and its occupants. For more details, see Sec. 15 and 18.

In addition to conductors and outlets, an electrical system also incorporates devices and apparatus for controlling electric voltage and current. Because electricity can be hazardous, the system must be designed and installed to prevent injury to occupants and damage to building components.

For more details, see Sec. 15.

Vertical-Circulation Elements. In multistory buildings, provision must be made for movement of people, supplies, and equipment between the various levels. This may be accomplished with ramps, stairs, escalators, elevators, dumbwaiters, vertical conveyors, pneumatic tubes, mail chutes, or belt conveyors. Some of the mechanical equipment, however, may not be used for conveyance of people.

A **ramp**, or sloping floor, is often used for movement of people and vehicles in such buildings as stadiums and garages. In most buildings, however, stairs are installed because they can be placed on a steeper slope and therefore occupy less space than ramps. Nevertheless, federal rules require at least one handicap accessible entrance for all new buildings.

A **stairway** consists of a series of steps and landings. Each **step** consists of a horizontal platform, or **tread**, and a vertical separation or enclosure, called a **riser** (Fig. 1.9a). Railings are placed along the sides of the stairway and floor openings for safety reasons. Also, structural members may be provided to support the stairs and the floor edges. Often, in addition, the stairway must be enclosed for fire protection.

Escalators, or powered stairs, are installed in such buildings as department stores and transportation terminals, or in the lower stories of office buildings and hotels, where there is heavy pedestrian traffic between floors. Such powered stairs consist basically of a conveyor belt with steps attached; an electric motor for moving the belt, and steps, controls, and structural supports.

Elevators are installed to provide speedier vertical transportation, especially in tall buildings. Transportation is provided in an enclosed car that moves along guides, usually within a fire-resistant vertical shaft but sometimes unenclosed along the exterior of a building. The shaft, or the exterior wall, has openings, protected by doors, at each floor to provide access to the elevator car. The car may be suspended on and moved by cables (Fig. 1.9b) or set atop a piston moved by hydraulic pressure (Fig. 1.9c).

More information on vertical-circulation elements is given in Sec. 16.

Intelligent Buildings. In addition to incorporating the major systems previously described, intelligent buildings, through the use of computers and communication equipment, have the ability to control the total building environment. The equipment and operating personnel can be stationed in a so-called **control center** or the equipment can be monitored and controlled remotely via a computer, modem and telephone line. Various sensors and communication devices, feeding information to and from the control center, are located in key areas throughout the building for the purposes of analyzing and adjusting the environment, delivering messages during emergencies, and dispatching repair personnel and security guards, as needed.

To conserve energy, lighting may be operated by sensors that detected people movement. HVAC may be adjusted in accordance with temperature changes. Ele-

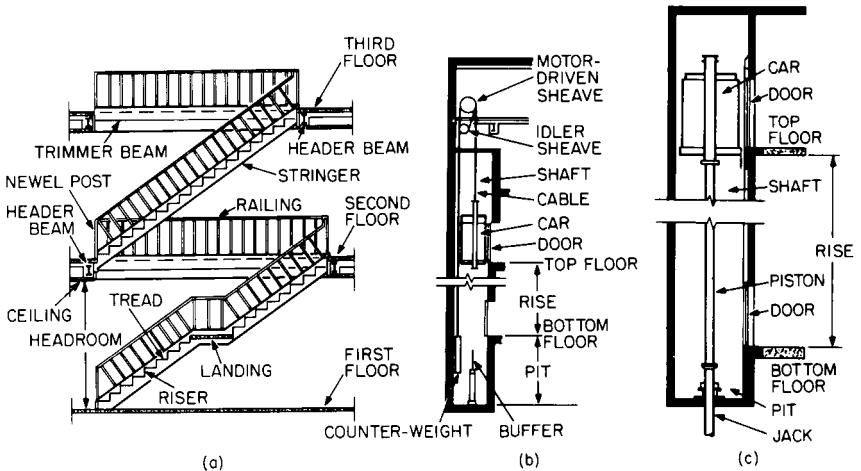

FIGURE 1.9 Vertical-circulation elements: (a) stairs; (b) electric traction elevator; (c) hydraulic elevator.

vators may be programmed for efficient handling of variations in traffic patterns and may be equipped with voice synthesizers to announce floor stops and give advice in emergencies. In addition, intelligent buildings are designed for ease and flexibility in providing for changes in space use, piping, electrical conductors, and installed equipment. See also Arts. 3.5.12 and 3.7.2.

(F. S. Merritt and J. Ambrose, "Building Engineering and Systems Design," 2nd Ed., Van Nostrand Reinhold, New York.)

1.8 VALUE ENGINEERING

As indicated in Art. 1.3, the client in the initial design phase develops a program, or list of requirements. The goal of the designers is to select a system that meets these requirements. Before the designers do this, however, it is advisable for them to question whether the requirements represent the client's actual needs. Can the criteria and standards affecting the design be made less stringent? After the program has been revised to answer these questions, the designers select a system. Next, it is advisable for the designers to question whether the system provides the best value at the lowest cost. Value engineering is a useful procedure for answering this question and selecting a better alternative if the answer indicates this is desirable.

Value engineering is the application of the scientific method to the study of values of systems. The major objective of value engineering in building design and construction is reduction of initial and life-cycle costs (Art. 1.6). Thus, value engineering has one of the objectives of systems design, in which the overall goal is production of an optimum building, and should be incorporated in the systems-design procedure.

The **scientific method**, which is incorporated in the definitions of value engineering and systems design, consists of the following steps:

1. Collection of data and observations of natural phenomena
2. Formulation of a hypothesis capable of predicting future observations
3. Testing of the hypothesis to verify the accuracy of its predictions and abandonment or improvement of the hypothesis if it is inaccurate

Those who conduct or administer value studies are often called **value engineers**, or **value analysts**. They generally are organized into an interdisciplinary team for value studies for a specific project. Sometimes, however, an individual, such as an experienced contractor, performs value engineering services for the client for a fee or a percentage of savings achieved by the services.

Value Analysis. Value is a measure of benefits anticipated from a system or from the contribution of a component to system performance. This measure must be capable of serving as a guide in a choice between alternatives in evaluations of system performance. Because generally in comparisons of systems only relative values need be considered, value takes into account both advantages and disadvantages, the former being considered positive and the latter negative. It is therefore possible in comparisons of systems that the value of a component of a system may be negative and subtracts of systems from the overall performance of the system.

System evaluations would be relatively easy if a monetary value could always be placed on performance. Then, benefits and costs could be compared directly.

Value, however, often must be based on a subjective decision of the client. For example, how much extra is an owner willing to pay for beauty, prestige, or better community relations? Will the owner accept gloom, glare, draftiness, or noise for a savings in cost? Consequently, other values than monetary must be considered in value analysis. Such considerations require determination of the relative importance of the client's requirements and weighting of values accordingly.

Value analysis is the part of the value-engineering procedure devoted to investigation of the relation between costs and values of components and systems and alternatives to these. The objective is to provide a rational guide for selection of the lowest-cost system that meets the client's actual needs.

Measurement Scales. For the purposes of value analysis, it is essential that characteristics of a component or system on which a value is to be placed be distinguishable. An analyst should be able to assign different numbers, not necessarily monetary, to values that are different. These numbers may be ordinates of any one of the following four measurement scales: ratio, interval, ordinal, nominal.

Ratio Scale. This scale has the property that, if any characteristic of a system is assigned a value number k , any characteristic that is n times as large must be assigned a value number nk . Absence of the characteristic is assigned the value zero. This type of scale is commonly used in engineering, especially in cost comparisons. For example, if a value of \$10,000 is assigned to system A and of \$5000 to system B, then A is said to cost twice as much as B.

Interval Scale. This scale has the property that equal intervals between assigned values represent equal differences in the characteristic being measured. The scale zero is assigned arbitrarily. The Celsius scale of temperature measurements is a good example of an interval scale. Zero is arbitrarily established as the temperature at which water freezes; the zero value does not indicate absence of heat. The boiling point of water is arbitrarily assigned the value of 100. The scale between 0 and 100 is then divided into 100 equal intervals called degrees ($^{\circ}\text{C}$). Despite the arbitrariness of the selection of the zero point, the scale is useful in heat measurement. For example, changing the temperature of an objective from 40°C to 60°C , an increase of 20°C , requires twice as much heat as changing the temperature from 45°C to 55°C , an increase of 10°C .

Ordinal Scale. This scale has the property that the magnitude of a value number assigned to a characteristic indicates whether a system has more, or less, of the characteristic than another system has or is the same with respect to that characteristic. For example, in a comparison of the privacy afforded by different types of partitions, each may be assigned a number that ranks it in accordance with the degree of privacy that it provides. Partitions with better privacy are given larger numbers. Ordinal scales are commonly used when values must be based on subjective judgments of nonquantifiable differences between systems.

Nominal Scale. This scale has the property that the value numbers assigned to a characteristic of systems being compared merely indicate whether the systems differ in this characteristic. But no value can be assigned to the difference. This type of scale is often used to indicate the presence or absence of a characteristic or component. For example, the absence of a means of access to equipment for maintenance may be represented by zero or a blank space, whereas the presence of such access may be denoted by 1 or X.

Weighting. In practice, construction cost usually is only one factor, perhaps the only one with a monetary value, of several factors that must be evaluated in a comparison of systems. In some cases, some of the other characteristics of the

system may be more important to the owner than cost. Under such circumstances, the comparison may be made by use of an ordinal scale for ranking each characteristic and then weighting the rankings in accordance with the importance of the characteristic to the owner.

As an example of the use of this procedure, calculations for comparison of two partitions are shown in Table 1.1. Alternative 1 is an all-metal partition and alternative 2 is made of glass and metal.

In Table 1.1, characteristics of concern in the comparison are listed in the first column. The numbers in the second column indicate the relative importance of each characteristic to the owner: 1 denotes lowest priority and 10 highest priority. These are the weights. In addition, each of the partitions is ranked on an ordinal scale, with 10 as the highest value, in accordance with the degree to which it possesses each characteristic. These rankings are listed as relative values in Table 1.1. For construction cost, for instance, the metal partition is assigned a relative value of 10 and the glass-metal partition a value of 8, because the metal partition costs a little less than the other one. In contrast, the glass-metal partition is given a relative value of 8 for visibility, because the upper portion is transparent, whereas the metal partition has a value of zero, because it is opaque.

To complete the comparison, the weight of each characteristic is multiplied by the relative value of the characteristic for each partition and entered in Table 1.1 as a weighted value. For construction cost, for example, the weighted values are $8 \times 10 = 80$ for the metal partition and $8 \times 8 = 64$ for the glass-metal partition. The weighted values for each partition are then added, yielding 360 for alternative 1 and 397 for alternative 2. While this indicates that the glass-metal partition is better, it may not be the best for the money. To determine whether it is, the weighted value for each partition is divided by its cost, yielding 0.0300 for the metal partition

TABLE 1.1 Comparison of Alternative Partitions*

Characteristics	Relative importance	Alternatives			
		1 All metal		2 Glass and metal	
		Relative value	Weighted value	Relative value	Weighted value
Construction cost	8	10	80	8	64
Appearance	9	7	63	9	81
Sound transmission	5	5	25	4	20
Privacy	3	10	30	2	6
Visibility	10	0	0	8	80
Movability	2	8	16	8	16
Power outlets	4	0	0	0	0
Durability	10	9	90	9	90
Low maintenance	8	7	56	5	40
Total weighted values			360		397
Cost			\$12,000		\$15,000
Ratio of values to cost			0.0300		0.0265

*Reprinted with permission from F. S. Merritt, "Building Engineering and Systems Design," Van Nostrand Reinhold Company, New York.

and 0.0265 for the other. Thus, the metal partition appears to offer more value for the money and would be recommended.

Economic Comparisons. In a choice between alternative systems, only the differences between system values are significant and need to be compared.

Suppose, for example, the economic effect of adding 1 in of thermal insulation to a building is to be investigated. In a comparison, it is not necessary to compute the total cost of the building with and without the insulation. Generally, the value analyst need only subtract the added cost of 1 in of insulation from the decrease in HVAC cost to obtain the net saving or cost increase resulting from addition of insulation. A net saving would encourage addition of insulation. Thus, a decision can be reached without the complex computation of total building cost.

In evaluating systems, value engineers must take into account not only initial and life-cycle costs but also the return the client wishes to make on the investment in the building. Generally, a client would like not only to maximize profit, the difference between revenue from use of the building and total costs, but also to ensure that the rate of return, the ratio of profit to investment, is larger than all of the following:

- Rate of return expected from the type of business
- Interest rate for borrowed money
- Rate for government bonds or notes
- Rate for highly rated corporate bonds

The client is concerned with interest rates because all costs represent money that must be borrowed or that could otherwise be invested at a current interest rate. The client also has to be concerned with time, measured from the date at which an investment is made, because interest cost increases with time. Therefore, in economic comparisons of systems, interest rates and time must be taken into account. (Effects of monetary inflation can be taken into account in much the same way as interest.)

An economic comparison usually requires evaluation of initial capital investments, salvage values after several years, annual disbursements and annual revenues. Because each element in such a comparison may have associated with it an expected useful life different from that of the other elements, the different types of costs and revenues must be made commensurable by reduction to a common basis. This is commonly done by either:

1. Converting all costs and revenues to equivalent uniform annual costs and income
2. Converting all costs and revenues to present worth of all costs and revenues at time zero.

Present worth is the money that, invested at time zero, would yield at later times required costs and revenues at a specified interest rate. In economic comparisons, the conversions should be based on a rate of return on investment that is attractive to the client. It should not be less than the interest rate the client would have to pay if the amount of the investment had to be borrowed. For this reason, the desired rate of return is called interest rate in conversions. Calculations also should be based on actual or reasonable estimates of time periods. Salvage values, for instance, should be taken as the expected return on sale or trade-in of an item

after a specific number of years that it has been in service. Interest may be considered compounded annually.

Future Value. Based on the preceding assumptions, a sum invested at time zero increases in time to

$$S = P(1 + i)^n \quad (1.1)$$

where S = future amount of money, equivalent to P , at the end of n periods of time with interest i

i = interest rate

n = number of interest periods, years

P = sum of money invested at time zero = present worth of S

Present Worth. Solution of Eq. (1.1) for P yields the present worth of a sum of money S at a future date:

$$P = S(1 + i)^{-n} \quad (1.2)$$

The present worth of payments R made annually for n years is

$$P = R \frac{1 - (1 + i)^{-n}}{i} \quad (1.3)$$

The present worth of the payments R continued indefinitely can be obtained from Eq. (1.3) by making n infinitely large:

$$P = \frac{R}{i} \quad (1.4)$$

Capital Recovery. A capital investment P at time zero can be recovered in n years by making annual payments of

$$R = P \frac{i}{1 - (1 + i)^{-n}} = P \left[\frac{i}{(1 + i)^n - 1} + i \right] \quad (1.5)$$

When an item has salvage value V after n years, capital recovery R can be computed from Eq. (1.5) by subtraction of the present worth of the salvage value from the capital investment P .

$$R = [P - V(1 + i)^{-n}] \left[\frac{i}{(1 + i)^n - 1} + i \right] \quad (1.6)$$

Example. To illustrate the use of these formulas, an economic comparison is made in the following for two air-conditioning units being considered for an office building. Costs are estimated as follows:

	Unit 1	Unit 2
Initial cost	\$300,000	\$500,000
Life, years	10	20
Salvage value	\$50,000	\$100,000
Annual costs	\$30,000	\$20,000

Cost of operation, maintenance, repairs, property taxes, and insurance are included in the annual costs. The present-worth method is used for the comparison, with interest rate $i = 8\%$.

Conversion of all costs and revenues to present worth must be based on a common service life, although the two units have different service lives, 10 and 20 years, respectively. For the purpose of the conversion, it may be assumed that replacement assets will repeat the investment and annual costs predicted for the initial asset. (Future values, however, should be corrected for monetary inflation.) In some cases, it is convenient to select for the common service life the least common multiple of the lives of the units being compared. In other cases, it may be more convenient to assume that the investment and annual costs continue indefinitely. The present worth of such annual costs is called **capitalized cost**.

For this example, a common service life of 20 years, the least common multiple of 10 and 20, is selected. Hence, it is assumed that unit 1 will be replaced at the end of the tenth period at a cost of \$300,000 less the salvage value. Similarly, the replacement unit will be assumed to have the same salvage value after 20 years.

The calculations in Table 1.2 indicate that the present worth of the net cost of unit 2 is less than that for unit 1. If total cost during the twenty year period were the sole consideration, purchase of unit 2 would be recommended.

ASTM has developed several standard procedures for making economic studies of buildings and building systems, in addition to ASTM E917 for measuring life-cycle costs, mentioned previously. For example, ASTM E964 is titled Practice for Measuring Benefit-to-Cost and Savings-to-Investment Ratios for Buildings and Building Systems. Other standards available present methods for measuring internal rate of return, net benefits, and payback. ASTM also has developed computer programs for these calculations.

Value Analysis Procedure. In building design, value analysis generally starts with a building system or subsystem proposed by the architect and consultants. The client or the client's representative appoints an interdisciplinary team to study the system or subsystem and either recommend its use or propose a more economical alternative. The team coordinator sets goals and priorities for the study and may appoint task groups to study parts of the building in accordance with the priorities. The value analysts should follow a systematic, scientific procedure for accomplishing

TABLE 1.2 Example Comparison of Two Air-Conditioning Units

	Unit 1	Unit 2
Initial investment	\$300,000	\$500,000
Present worth of replacement cost in 10 years $P - V$ at 8% interest [Eq. (1.2)]	115,800	
Present worth of annual cost for 20 years at 8% interest [Eq. (1.3)]	294,540	196,360
Present worth of all costs	710,340	696,360
<i>Revenue:</i>		
Present value of salvage value after 20 years at 8% interest [Eq. (1.2)]	10,730	21,450
<i>Net cost:</i>		
Present worth of net cost in 20 years at 8% interest	\$699,610	\$674,910

all the necessary tasks that comprise a value analysis. The procedure should provide an expedient format for recording the study as it progresses, assure that consideration has been given to all information, some of which may have been overlooked in development of the proposed system, and logically resolve the analysis into components that can be planned, scheduled, budgeted, and appraised.

The greatest cost reduction can be achieved by analysis of every component of a building. This, however, is not practical, because of the short time usually available for the study and because the cost of the study increases with time. Hence, it is advisable that the study concentrate on those building systems (or subsystems) whose cost is a relatively large percentage of the total building (or system) cost, because those components have possibilities for substantial cost reduction.

During the initial phase of value analysis, the analysts should obtain a complete understanding of the building and its major systems by rigorously reviewing the program, proposed design and all other pertinent information. They should also define the functions, or purposes, of each building component to be studied and estimate the cost of accomplishing the functions. Thus, the analysts should perform a systems analysis, as indicated in Art. 1.2, answer the questions listed in Art 1.2 for the items to be studied, and estimate the initial and life-cycle costs of the items.

In the second phase of value analysis, the analysts should question the cost-effectiveness of each component to be studied. Also, by use of imagination and creative techniques, they should generate several alternative means for accomplishing the required functions of the component. Then, in addition to answers to the questions in Art. 1.2, the analysts should obtain answers to the following questions:

Do the original design and each alternative meet performance requirements?

What does each cost installed and over the life cycle?

Will it be available when needed? Will skilled labor be available?

Can any components be eliminated?

What other components will be affected by adoption of an alternative? What will the resulting changes in the other components cost? Will there be a net saving in cost?

In investigating the possibility of elimination of a component, the analysts also should see if any part of it can be eliminated, if two parts or more can be combined into one, and if the number of different sizes and types of an element can be reduced. If costs might be increased by use of a nonstandard or unavailable item, the analysts should consider substitution of a more appropriate alternative. In addition, consideration should be given to simplification of construction or installation of components and to ease of maintenance and repair.

In the following phase of value analysis, the analysts should critically evaluate the original design and alternatives. The ultimate goal should be recommendation of the original design and alternative, whichever offers the greatest value and cost-savings potential. The analysts also should submit estimated costs for the original design and the alternative.

In the final phase, the analysts should prepare and submit to the client or the client's representative who appointed them a written report on the study and resulting recommendations. Also, they should submit a workbook containing detailed backup information.

Value engineering should start during the conceptual phase of design. Then, it has the greatest impact on cost control and no cost is involved in making design changes. During later design phases, design changes involve some cost, especially

when substitution of major subsystems is involved, but the cost is nowhere near as great as when changes are made during construction. Such changes should be avoided if possible. Value engineering, however, should be applied to the project specifications and construction contract. Correction of unnecessary and overconservative specifications and contract provisions offers considerable potential for cost reduction.

(E. D. Heller, "Value Management: Value Engineering and Cost Reduction," Addison-Wesley, Reading, Mass.; L. D. Miles, "Techniques of Value Analysis and Engineering," McGraw-Hill Publishing Co., New York; A Mudge, "Value Engineering," McGraw-Hill Publishing Company, New York; M. C. Macedo, P. V. Dobrow, and J. J. O'Rourke, "Value Management for Construction," John Wiley & Sons, Inc., New York.)

1.9 EXECUTION OF SYSTEMS DESIGN

The basic traditional design procedure (Art. 1.3), which has been widely used for many years, and commonly used variations of it have resulted in many excellent buildings. It needs improvement, however, because clients cannot be certain that its use gives the best value for the money or that the required performance could not have been attained at lower cost. The uncertainty arises because historically:

1. Actual construction costs often exceed low bids or negotiated prices, because of design changes during construction; unanticipated delays during construction, which increase costs; and unforeseen conditions, such as unexpectedly poor sub-surface conditions that make excavation and foundation construction more expensive.
2. Construction, operation, or maintenance costs are higher than estimated, because of design mistakes or omissions.
3. Separation of design and construction into different specialties leads to underestimated or overestimated construction costs and antagonistic relations between designers and builders.
4. Construction costs are kept within the client's budget at the expense of later higher operating, maintenance, and repair costs.
5. Coordination of the output of architects and consultants is not sufficiently close for production of an optimum building for the client's actual needs.

One objective of systems design is to correct these defects. This can be done while retaining the desirable features of traditional procedures, such as development of building design in stages, with progressively more accurate cost estimates and frequent client review. Systems design therefore should at least do the following:

1. Question the cost effectiveness of proposed building components and stimulate generation of lower-cost alternatives that achieve the required performance. This can be done by incorporating value engineering in systems design.
2. More closely coordinate the work of various design specialists and engage building construction and operation experts to assist in design.
3. Take into account both initial and life-cycle costs.

4. Employ techniques that will reduce the number of design mistakes and omissions that are not discovered until after construction starts.

Systems Design Procedure. Article 1.2 defines systems and explains that systems design comprises a rational, orderly series of steps that leads to the best decision for a given set of conditions. Article 1.2 also lists the basic components of the procedure as analysis, synthesis, appraisal, and feedback. Following is a more formal definition:

Systems design is the application of the scientific method to selection and assembly of components or subsystems to form the optimum system to attain specified goals and objectives while subject to given constraints and restrictions.

The scientific method is defined in Art. 1.8. Goals, objectives, and constraints are discussed later.

Systems design of buildings, in addition to correcting defects in traditional design, must provide answers to the following questions:

1. What does the client actually want the building to accomplish (goals, objectives, and associated criteria)?
2. What conditions exist, or will exist after construction, that are beyond the designers' control?
3. What requirements for the building or conditions affecting system performance does design control (constraints and associated standards)?
4. What performance requirements and time and cost criteria can the client and designers use to appraise system performance?

Collection of information necessary for design of the building starts at the inception of design and may continue through the contract documents phase. Data collection is an essential part of systems design but because it is continuous throughout design it is not listed as one of the basic steps.

For illustrative purposes, the systems design procedure is shown resolved into nine basic steps in Fig. 1.10. Because value analysis is applied in step 5, steps 4 through 8 covering synthesis, analysis, and appraisal may be repeated several times. Each iteration should bring the design closer to the optimum.

In preparation for step 1, the designers should secure a building program and information on existing conditions that will affect building design. In step 1, the designers use the available information to define goals to be met by the system.

Goals. These state what the building is to accomplish, how it will affect the environment and other systems, and how other systems and the environment will affect the building. Goals should be generalized but brief statements, encompassing all the design objectives. They should be sufficiently specific, however, to guide generation of initial and alternative designs and control selection of the best alternative.

A simple example of a goal is: Design a branch post-office building with 100 employees to be constructed on a site owned by the client. The building should harmonize with neighboring structures. Design must be completed within 90 days and construction within 1 year. Construction cost is not to exceed \$500,000.

When systems design is applied to a subsystem, goals serve the same purpose as for a system. They indicate the required function of the subsystem and how it affects and is affected by other systems.

Objectives. With the goals known, the designers can advance to step 2 and define the system objectives. These are similar to goals but supply in detail the requirements that the system must satisfy to attain the goals.

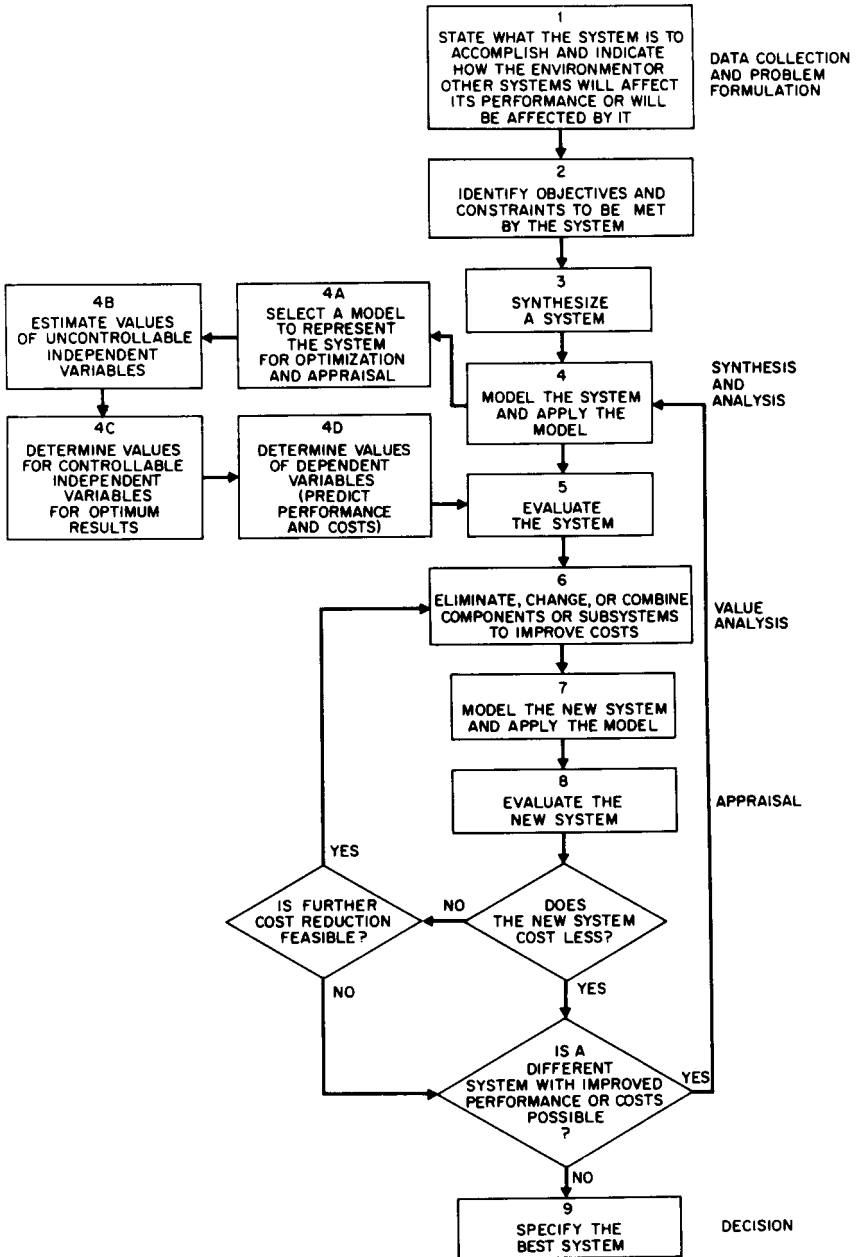

FIGURE 1.10 Basic steps in systems design in addition to collection of necessary information.

In listing objectives, the designers may start with broad generalizations that they later develop at more detailed levels to guide design of the system. Some objectives, such as minimization of initial costs, life-cycle costs and construction time, should be listed. Other objectives that apply to the design of almost every building, such as the health, safety, and welfare objectives of the building, zoning, and Occupational Safety and Health Administration regulations, are too numerous to list and may be adopted by reference. Objectives should be sufficiently specific to guide the planning of building interior spaces and selection of specific characteristics for the building and its components: appearance, strength, durability, stiffness, operational efficiency, maintenance, and fire resistance. Also, objectives should specify the degree of control needed for operation of systems provided to meet the other objectives.

At least one criterion must be associated with each objective. The criterion is a range of values within which the performance of the system must lie for the objective to be met. The criterion should be capable of serving as a guide in evaluations of alternative systems. For example, for fire resistance of a wall, the criterion might be 2-hr fire rating.

In addition to establishing criteria, the designers should weight the objectives in accordance with the relative importance of the objectives to the client (Art. 1.8). These weights should also serve as guides in comparisons of alternatives.

System Constraints. In step 2 of systems design, the designers should also define constraints on the system. Constraints are restrictions on the values of design variables that represent properties of the system and are controllable by the designers. Designers are seldom completely free to choose any values desired for controllable variables because of various restrictions, which may be legal ones such as building or zoning code requirements, or may be economic, physical, chemical, temporal, psychological, sociological, or esthetic requirements. Such restrictions may fix the values of the controllable variables or establish a range in which they must lie.

At least one standard must be associated with each constraint. A standard is a value or range of values governing a property of the system. The standard specifying a fixed value may be a minimum or maximum value.

For example, a designer may be seeking to determine the thickness of a load-bearing brick wall. The local building code may state that such a wall may not be less than 8 in thick. This requirement is a minimum standard. The designer may then select a wall thickness of 8 in or more. The requirements of other systems, however, may indicate that the wall thickness may not exceed 16 in. This is a maximum standard. Furthermore, bricks may be available only in nominal widths of 4 in. Hence, the constraints limit the values of the controllable variable, in this case wall thickness, to 8, 12, or 16 in.

Synthesis. In step 3, the designers must conceive at least one system that satisfies the objectives and constraints. For this, they rely on their past experience, knowledge, imagination, and creative skills and on advice from consultants, including value engineers, construction experts, and experienced operators of the type of facilities to be designed.

In addition, the designers should select systems that are cost-effective and can be erected speedily. To save design time in selection of a system, the designers should investigate alternative systems in a logical sequence for potential for achieving optimum results. The following is a possible sequence:

1. Selection of an available industrialized building, a system that is preassembled in a factory. Such a system is likely to be low cost, because of the use of mass-

production techniques and factory wages, which usually are lower than those for field personnel. Also, the quality of materials and construction may be better than for custom-built structures, because of assembly under controlled conditions and close supervision.

2. Design of an industrialized building (if the client needs several of the same type of structure).
3. Assembling a building with prefabricated components or systems. This type of construction is similar to that used for industrialized buildings except that the components preassembled are much smaller parts of the building system.
4. Specification of as many prefabricated and standard components as feasible. Standard components are off-the shelf items, readily available from building supply companies.
5. Repetition of the same component as many times as possible. This may permit mass production of some nonstandard components. Also, repetition may speed construction, because field personnel will work faster as they become familiar with the components.
6. Design of components for erection so that building trades will be employed on the site continuously. Work that compels one trade to wait for completion of work by another trade delays construction and is costly.

Models. In step 4, the designers should represent the system by a model that will enable them to analyze the system and evaluate its performance. The model should be simple, consistent with the role for which it is selected, for practical reasons. The cost of formulating and using the model should be negligible compared with the cost of assembling and testing the actual system.

For every input to a system, there must be a known, corresponding input to the model such that the responses (output) of the model to that input are determinable and correspond to the response of the system to its input. The correlation may be approximate but nevertheless close enough to serve the purposes for which the model is to be used. For example, for cost estimates during the conceptual phase of design, use may be made of a cost model that yields only reasonable guesses of construction costs. The cost model used in the contract documents phase, however, should be accurate.

Models may be classified as iconic, symbolic, or analog. The **iconic type** may be the actual system or a part of it or merely bear a physical resemblance to the actual system. This type is often used for physical tests of performance, such as load or wind-tunnel tests or adjustments of controls. **Symbolic models** represent by symbols the input and output of a system and are usually amenable to mathematical analysis of a system. They enable relationships to be generally, yet compactly, expressed, are less costly to develop and use than other types of models, and are easy to manipulate. **Analog models** are real systems but with physical properties different from those of the actual system. Examples include dial watches for measuring time, thermometers for measuring heat changes, slide rules for multiplying numbers, flow of electric current for measuring heat flow through a metal plate, and soap membranes for measuring torsion in an elastic shaft.

Variables representing input and properties of a system may be considered independent variables. These are of two types:

1. Variables that the designers can control or constraints: x_1, x_2, x_3, \dots
2. Variables that are uncontrollable: y_1, y_2, y_3, \dots

Variables representing system output or performance may be considered dependent variables: z_1, z_2, z_3, \dots

The dependent variables are functions of the independent variables. These functions also contain parameters, which can be adjusted in value to calibrate the model to the behavior of the actual system.

Step 4 of systems design then may be resolved into four steps, as indicated in Fig. 1.10:

1. Select and calibrate a model to represent the system for optimization and appraisal.
2. Estimate values for the uncontrollable, independent variables.
3. Determine values for the controllable variables.
4. Determine the output or performance of the system from the relationship of dependent and independent variables by use of the model.

Cost Models. As an example of the use of models in systems design, consider the following cost models:

$$C = Ap \quad (1.7)$$

where C = construction cost of building
 A = floor area, ft², in the building
 p = unit construction cost, dollars per square foot

This is a symbolic model applicable only in the early stages of design when systems and subsystems are specified only in general form. Both A and p are estimated, usually on the basis of past experience with similar types of buildings.

$$C = \sum A_i p_i \quad (1.8)$$

where A_i = convenient unit of measurement for the i th system
 p_i = cost per unit for the i th system

This symbolic cost model is suitable for estimating building construction cost in preliminary design stages after types of major systems have been selected. Equation (1.8) gives the cost as the sum of the cost of the major systems, to which should be added the estimated costs of other systems and contractor's overhead and profit. A_i may be taken as floor or wall area, square feet, pounds of steel, cubic yards of concrete, or any other applicable parameter for which the unit cost may be reasonably accurately estimated.

$$C = \sum A_j p_j \quad (1.9)$$

where A_j = convenient unit of measurement for the j th subsystem
 p_j = cost per unit for the j th subsystem

This symbolic model may be used in the design development phase and later after components of the major systems have been selected and greater accuracy of the cost estimate is feasible. Equation (1.9) gives the construction cost as the sum of the costs of all the subsystems, to which should be added contractor's overhead and profit.

For more information on cost estimating, see Sec. 19.

Optimization. The objective of systems design is to select the single best system for a given set of conditions, a process known as optimization. When more than one property of the system is to be optimized or when there is a single characteristic to be optimized but it is nonquantifiable, an optimum solution may or may not exist. If it does exist, it may have to be found by trial and error with a model or by methods such as those described in Art. 1.8.

When one characteristic, such as construction cost, of a system is to be optimized, the criterion may be expressed as

$$\text{Optimize } z_r = f_r(x_1, x_2, x_3, \dots y_1, y_2, y_3, \dots) \quad (1.10)$$

where z_r = dependent variable to be maximized or minimized

x = controllable variable, identified by a subscript

y = uncontrollable variable, identified by a subscript

f_r = objective function

Generally, however, there are restrictions on values of the independent variables. These restrictions may be expressed as

$$\begin{aligned} f_1(x_1, x_2, x_3, \dots y_1, y_2, y_3, \dots) &\geq 0 \\ f_2(x_1, x_2, x_3, \dots y_1, y_2, y_3, \dots) &\geq 0 \\ \dots\dots\dots & \\ f_n(x_1, x_2, x_3, \dots y_1, y_2, y_3, \dots) &\geq 0 \end{aligned} \quad (1.11)$$

Simultaneous solution of Eqs. (1.10) and (1.11) yields the optimum values of the variables. The solution may be obtained by use of such techniques as calculus, linear programming, or dynamic programming depending on the nature of the variables and the characteristics of the equations.

Direct application of Eqs. (1.10) and (1.11) to a whole building, its systems, and its larger subsystems usually is impractical, because of the large number of variables and the complexity of their relationships. Hence optimization generally has to be attained in a different way, generally by such methods as suboptimization or simulation.

Systems with large numbers of variables may sometimes be optimized by a process called **simulation**, which involves trial and error with the actual system or a model. In simulation, the properties of the system or model are adjusted with a specific input or range of inputs to the system, and outputs or performance are measured until an optimum result is obtained. When the variables are quantifiable and models are used, the solution usually can be expedited by use of computers. The actual system may be used when it is available and accessible and changes in it will have little or no effect on construction costs. For example, after installation of air ducts, an air-conditioning system may be operated for a variety of conditions to determine the optimum damper position for control of airflow for each condition.

Suboptimization is a trial-and-error process in which designers try to optimize a system by first optimizing its subsystems. It is suitable when components influence each other in series. For example, consider a structural system consisting only of roof, columns, and footings. The roof has a known load (input), exclusive of its own weight. Design of the roof affects the columns and footings, because its output equals the load on the columns. Design of the columns loads only the footings.

Design of the footings, however, has no effect on any of the other structural components. Therefore, the structural components are in series and they may be designed by suboptimization to obtain the minimum construction cost or least weight of the system.

Suboptimization of the system may be achieved by first optimizing the footings, for example, designing the lowest-cost footings. Next, the design of both the columns and the footings should be optimized. (Optimization of the columns alone will not yield an optimum structural system, because of the effect of the column weight on the footings.) Finally, roof, columns, and footings together should be optimized. (Optimization of the roof alone will not yield an optimum structural system, because of the effect of its weight on columns and footings. A low-cost roof may be very heavy, requiring costly columns and footings, whereas the cost of a lightweight roof may be so high as to offset any savings from less-expensive columns and footings. An alternative roof may provide optimum results.)

Appraisal. In step 5 of systems design, the designers should evaluate the results obtained in step 4, modeling the system and applying the model. The designers should verify that construction and life-cycle costs will be acceptable to the client and that the proposed system satisfies all objectives and constraints.

During the preceding steps, value analysis may have been applied to parts of the building. In step 6, however, value analysis should be applied to the whole building system. This process may result in changes only to parts of the system, producing a new system, or several alternatives to the original design may be proposed. In steps 7 and 8, therefore, the new systems, or at least those with good prospects, should be modeled and evaluated. During and after this process, completely different alternatives may be conceived. As a result, steps 4 through 8 should be repeated for the new concepts. Finally, in step 9, the best of the systems studied should be selected.

(R. J. Aguilar, "Systems Analysis and Design in Engineering, Architecture Construction and Planning," Prentice-Hall, Inc., Englewood Cliffs, N.J.; R. L. Ackoff and M. W. Saseini, "Fundamentals of Operations Research," John Wiley & Sons, Inc., New York; K. I. Majid, "Optimum Design of Structures," Halsted Press/Wiley, New York; E. J. McCormick, "Human Factors in Engineering," McGraw-Hill Publishing Company, New York; F. S. Merritt and J. A. Ambrose, "Building Engineering and Systems Design," 2nd Ed., Van Nostrand Reinhold, New York; R. DeNeufville and J. H. Stafford, "Systems Analysis for Engineers and Managers," McGraw-Hill Publishing Company, New York; L. Spunt, "Optimum Structural Design," Prentice-Hall, Englewood Cliffs, N.J.)

1.10 BUILDING CODES

Many of the restrictions encountered in building design are imposed by legal regulations. While all must be met, those in building codes are the most significant because they affect almost every part of a building.

Building codes are established under the police powers of a state to protect the health, welfare, and safety of communities. A code is administered by a building official of the municipality or state that adopts it by legislation. Development of a local code may be guided by a model code, such as those promulgated by the International Conference of Building Officials, Inc., Building Officials and Code Administrators International, Inc., and Southern Building Code Congress International, Inc.

In general, building-code requirements are the minimum needed for public protection. Design of a building must satisfy these requirements. Often, however, architects and engineers must design more conservatively, to meet the client's needs, produce a more efficient building system, or take into account conditions not covered fully by code provisions.

Construction drawings for a building should be submitted to the building-code administrator before construction starts. If the building will meet code requirements, the administrator issues a building permit, on receipt of which the contractor may commence building. During construction, the administrator sends inspectors periodically to inspect the work. If they discover a violation, they may issue an order to remove it or they may halt construction, depending on the seriousness of the violation. On completion of construction, if the work conforms to code requirements, the administrator issues to the owner a certificate of occupancy.

Forms of Codes. Codes often are classified as specifications type or performance type. A specification-type code names specific materials for specific uses and specifies minimum or maximum dimensions, for example, "a brick wall may not be less than 6 in thick." A performance-type code, in contrast, specifies required performance of a construction but leaves materials, methods, and dimensions for the designers to choose. Performance-type codes are generally preferred, because they give designers greater design freedom in meeting clients' needs, while satisfying the intent of the code. Most codes, however, are neither strictly specifications nor performance type but rather a mixture of the two. The reason for this is that insufficient information is currently available for preparation of an entire enforceable performance code.

The organization of building codes varies with locality. Generally, however, they consist of two parts, one dealing with administration and enforcement and the other specifying requirements for design and construction in detail.

Part 1 usually covers licenses, permits, fees, certificates of occupancy, safety, projections beyond street lines, alterations, maintenance, applications, approval of drawings, stop-work orders, and posting of buildings to indicate permissible live loads and occupant loads.

Part 2 gives requirements for structural components, lighting, HVAC, plumbing, gas piping and fixtures, elevators and escalators, electrical distribution, stairs, corridors, walls, doors, and windows. This part also defines and sets limits on occupancy and construction-type classifications. In addition, the second part contains provisions for safety of public and property during construction operations and for fire protection and means of egress after the building is occupied.

Many of the preceding requirements are *adopted by reference* in the code from nationally recognized standards or codes of practice. These may be promulgated by agencies of the federal government or by such organizations as the American National Standards Institute, ASTM, American Institute of Steel Construction, American Concrete Institute, and American Institute of Timber Construction.

Code Classifications of Buildings. Building codes usually classify a building in accordance with the fire zone in which it is located, the type of occupancy, and the type of construction, which is an indication of the fire protection offered.

The **fire zone** in which a building is located may be determined from the community's fire-district zoning map. The building code specifies the types of construction and occupancy groups permitted or prohibited in each fire zone.

The **occupancy group** to which a building official assigns a building depends on the use to which the building is put. Typical classifications include one- and two-story dwellings; apartment buildings, hotels, dormitories; industrial buildings

with noncombustible, combustible, or hazardous contents; schools; hospitals and nursing homes; and places of assembly, such as theaters, concert halls, auditoriums, and stadiums.

Type of construction of a building is determined, in general, by the fire ratings assigned to its components. A code usually establishes two major categories: combustible and noncombustible construction. The combustible type may be subdivided in accordance with the fire protection afforded major structural components and the rate at which they will burn; for example, heavy timber construction is considered slow-burning. The noncombustible type may be subdivided in accordance with the fire-resistive characteristics of components.

Building codes may set allowable floor areas for fire-protection purposes. The limitations depend on occupancy group and type of construction. The purpose is to delay or prevent spread of fire over large portions of the building. For the same reason, building codes also may restrict building height and number of stories. In addition, to permit rapid and orderly egress in emergencies, such as fire, codes limit the occupant load, or number of persons allowed in a building or room. In accordance with permitted occupant loads, codes indicate the number of exits of adequate capacity and fire protection that must be provided.

1.11 ZONING CODES

Like building codes, zoning codes are established under the police powers of the state, to protect the health, welfare, and safety of the public. Zoning, however, primarily regulates land use by controlling types of occupancy of buildings, building height, and density and activity of population in specific parts of a jurisdiction.

Zoning codes are usually developed by a planning commission and administered by the commission or a building department. Land-use controls adopted by the local planning commission for current application are indicated on a zoning map. It divides the jurisdiction into districts, shows the type of occupancy, such as commercial, industrial, or residential, permitted in each district, and notes limitations on building height and bulk and on population density in each district.

The planning commission usually also prepares a master plan as a guide to the growth of the jurisdiction. A future land-use plan is an important part of the master plan. The commission's objective is to steer changes in the zoning map in the direction of the future land-use plan. The commission, however, is not required to adhere rigidly to the plans for the future. As conditions warrant, the commission may grant variances from any of the regulations.

In addition, the planning commission may establish land subdivision regulations, to control development of large parcels of land. While the local zoning map specifies minimum lot area for a building and minimum frontage a lot may have along a street, subdivision regulations, in contrast, specify the level of improvements to be installed in new land-development projects. These regulations contain criteria for location, grade, width, and type of pavement of streets, length of blocks, open spaces to be provided, and right of way for utilities.

A jurisdiction may also be divided into fire zones in accordance with population density and probable degree of danger from fire. The fire-zone map indicates the limitations on types of construction that the zoning map would otherwise permit.

In the vicinity of airports, zoning may be applied to maintain obstruction-free approach zones for aircraft and to provide noise-attenuating distances around the

airports. Airport zoning limits building heights in accordance with distance from the airport.

Control of Building Height. Zoning places limitations on building dimensions to limit population density and to protect the rights of occupants of existing buildings to light, air, and esthetic surroundings. Various zoning ordinances achieve these objectives in a variety of ways, including establishment of a specific maximum height or number of stories, limitation of height in accordance with street width, setting minimums for distances of buildings from lot lines, or relating total floor area in a building to the lot area or to the area of the lot occupied by a building. Applications of some of these limitations are illustrated in Fig. 1.11.

Figure 1.11a shows a case where zoning prohibits buildings from exceeding 12 stories or 150 ft in height. Figure 1.11b illustrates a case where zoning relates building height to street width. In this case, for the specific street width, zoning permits a building to be erected along the lot boundary to a height of six stories or 85 ft. Greater heights are permitted, however, so long as the building does not penetrate *sky-exposure planes*. For the case shown in Fig. 1.11b, these planes start at the lot line at the 85-ft height and incline inward at a slope of 3:1. Some zoning codes will permit the upper part of the building to penetrate the planes if the floor area of the tower at any level does not exceed 40% of the lot area and the ratio of floor area to lot area (**floor-area ratio**) of the whole building does not exceed 15. To maximize the floor area in the building and maintain verticality of exterior walls, designers usually set back the upper parts of a building in a series of steps (Fig. 1.11b).

Some zoning ordinances, however, permit an alternative that many designers prefer. If the building is set back from the lot lines at the base to provide a street-level plaza, which is a convenience to the public and reduces building bulk, zoning

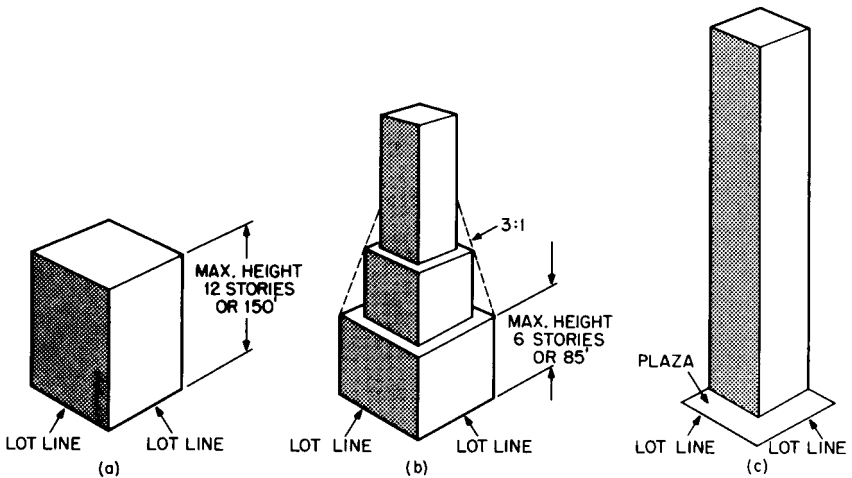

FIGURE 1.11 Examples of limitations placed by zoning codes on building height: (a) height limitations for buildings constructed along lot boundaries; (b) setbacks required by a 3:1 sky exposure plane; (c) height of a sheet tower occupying only part of a lot is limited by the total floor area permitted. (Reprinted with permission from F. S. Merritt and J. Ambrose, "Building Engineering and Systems Design," 2d ed., Van Nostrand Reinhold, New York.)

permits the building to be erected as a sheer tower (Fig. 1.11c). The code may set a maximum floor-area ratio of 15 or 18, depending on whether the floor area at any level of the tower does not exceed 50 or 40%, respectively, of the lot area.

1.12 OTHER REGULATIONS

In addition to building and zoning codes, building design and construction must comply with many other regulations. These include those of the local or state health, labor, and fire departments; local utility companies; and local departments of highways, streets, sewers, and water. These agencies may require that drawings for the building be submitted for review and that a permit be granted before construction starts.

Also, building construction and conditions in buildings after completion must comply with regulations of the U.S. Occupational Safety and Health Administration (OSHA) based on the Occupational Safety and Health Act originally passed by Congress in 1970. There is, however, no provision in this law for reviewing building plans before construction starts. OSHA usually inspects buildings only after an accident occurs or a complaint has been received. Therefore, building owners, designers, and contractors should be familiar with OSHA requirements and enforce compliance with them.

Other government agencies also issue regulations affecting buildings. For example, materials used in military construction must conform with federal specifications. Another example: Buildings must provide access and facilities for disabled persons, in accordance with requirements of the Americans with Disabilities Act (ADA).

[“Construction Industry: OSHA Safety and Health Standards (29CFR 1926/1910),” Superintendent of Documents, Government Printing Office, Washington, D.C. 20401; “ADA Compliance Guidebook,” Building Owners and Managers Association International,” 1201 New York Ave., N.W., Washington, D.C. 20005.]

1.13 SYSTEMS DESIGN BY TEAM

For efficient and successful execution of systems, design of buildings, a design organization superior to that used for traditional design (Art. 1.3) is highly desirable. For systems design, the various specialists required should form a building team, to contribute their skills in concert.

One reason why the specialists should work closely together is that in systems design account must be taken of the effects of each component on the performance of the building and of the interaction of building components. Another reason is that for cost effectiveness, unnecessary components should be eliminated and, where possible, two or more components should be combined. When the components are the responsibility of different specialists, these tasks can be accomplished with facility only when the specialists are in direct and immediate communication.

In addition to the design consultants required for traditional design, the building team should be staffed with value engineers, cost estimators, construction experts, and building operators and users experienced in operation of the type of building

to be constructed. Because of the diversity of skills present on such a team, it is highly probable that all ramifications of a decision will be considered and chances for mistakes and omissions will be reduced. See also Sec. 2.

(W. W. Caudill, "Architecture by Team," and F. S. Merritt and J. Ambrose, "Building Engineering and Systems Design," 2nd Ed., Van Nostrand Reinhold, New York.)

1.14 PROJECT PEER REVIEW

The building team should make it standard practice to have the output of the various disciplines checked at the end of each design step and especially before incorporation in the contract documents. Checking of the work of each discipline should be performed by a competent practitioner of that discipline other than the original designer and reviewed by principals and other senior professionals. Checkers should seek to ensure that calculations, drawings, and specifications are free of errors, omissions, and conflicts between building components.

For projects that are complicated, unique, or likely to have serious effects if failure should occur, the client or the building team may find it advisable to request a peer review of critical elements of the project or of the whole project. In such cases, the review should be conducted by professionals with expertise equal to or greater than that of the original designers, that is, by peers; and they should be independent of the building team, whether part of the same firm or an outside organization. The review should be paid for by the organization that requests it. The scope may include investigation of site conditions, applicable codes and governmental regulations, environmental impact, design assumptions, calculations, drawings, specifications, alternative designs, constructibility, and conformance with the building program. The peers should not be considered competitors or replacements of the original designers, and there should be a high level of respect and communication between both groups. A report of the results of the review should be submitted to the authorizing agency and the leader of the building team.

("The Peer Review Manual," American Consulting Engineers Council, 1015 15th St., NW, Washington, D.C. 20005, and "Peer Review, a Program Guide for Members of the Association of Soil and Foundation Engineers," ASFE, Silver Spring, MD.)

1.15 APPLICATION OF SYSTEMS DESIGN

Systems design may be used profitably in all phases of building design. Systems design, however, is most advantageous in the early design stages. One system may be substituted for another, and components may be eliminated or combined in those stages with little or no cost.

Systems design should be preferably applied in the contract documents stage only to the details being worked out then. Major changes are likely to be costly. Value analysis, though, should be applied to the specifications and construction contract, because such studies may achieve significant cost savings.

Systems design should be applied in the construction stage only when design is required because of changes necessary in plans and specifications at that time. Time available at that stage, however, may not be sufficient for thorough studies. Nevertheless, value analysis should be applied to the extent feasible.

(F. S. Merritt and J. Ambrose, "Building Engineering and Systems Design," 2nd Ed., Van Nostrand Reinhold, New York.)