

Resistive MHD Simulations of X-Line Retreat and Competing Reconnection Sites

Nicholas A. Murphy¹ & Aleida K. Young^{1, 2, 3}

Harvard-Smithsonian Center for Astrophysics
²Florida Institute of Technology

¹

Supported by the NSF-REU solar physics program at the CfA

³
52nd Annual Meeting of the APS Division of Plasma
Physics November 8–12, 2010

With thanks to: Carl Sovinec, John Raymond, Kelly Korreck, Paul Cassak, Mitsuo Oka, Jun Lin, & Chengcai Shen

This poster is available online at: <http://www.cfa.harvard.edu/~namurphy/publications.html>

X-line motion is frequently observed during magnetic reconnection in nature and the laboratory. Examples include :

X-line retreat in Earth's magnetotail (e.g., Runov et al. 2003; Eastwood et al. 2010)

Current sheets that form in the wakes of coronal mass ejections (CMEs)

Radial motion of the diffusion region during spherom

merging (e.g., Inomoto et al. 2006; Gray et al. 2010;

Ono et al. 1997; see also Murphy & Sovinec 2008)

Despite the prevalence of X-line retreat, it is standard practice to compare in situ measurements to particle-in-cell (PIC) simulations of roughly stationary reconnection layers

In this poster, we present resistive MHD simulations of X-line retreat and competing X-lines and derive an expression for the rate of X-line retreat

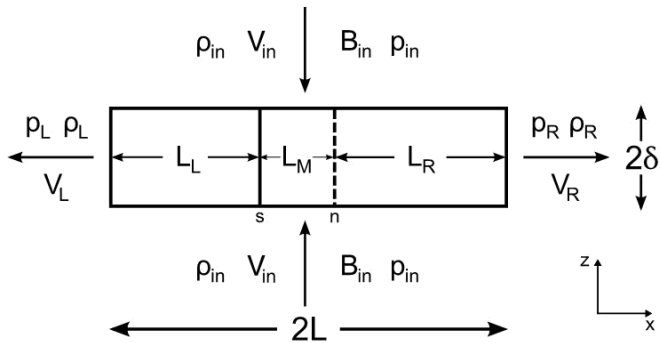

The connection layer with asymmetric downstream pressure. Reconnection is assumed to be steady in an inertial reference frame.

'n' denotes the magnetic field null and 's' denotes the flow stagnation point

figure presents a long and thin reconnection

R

 $2 \text{ in} +$
 $B \mu_0$
 $L \quad a \rho_L \frac{R^+}{L} \quad \frac{V_{2L}}{2R^2}$
 $a \rho_{in}$

d

$2 V_{inL}$ Following Cas sak & Shay (2007), we integrate over this control volume and find relations approximating conse rv

at mass, and energy
 on momentum $2\rho_{in}V_{in}L \sim \rho_L V_L d + \rho_R V_R d$
 of enthalpy $\rho_L V_L^2 + \rho_R V_R^2 + \rho_L a^2 + \rho_R a^2$
 $+V_R a^2 + \rho_R V_R^2$
 ρ

where $a = \gamma / (\gamma - 1)$ and we ignore upstream kinetic energy/downstream kinetic energy and assume the contribution from the shock along the boundary is small or even.

$$V_{2L} \text{ In the incompressible limit } \rho \frac{\Delta p}{2} = \frac{2\rho \pm}{\Delta p}$$

$$R \text{ it } \sim \frac{4}{C^2} c_{2 \text{ in}}$$

using $\bar{p} = \frac{p_L + p_R}{2}$

$$\eta \frac{(V_L - p_L) \text{ and } c_{2 \text{ in}}}{\rho L} = \frac{B_{2 \text{ in}}}{\mu \rho \text{ in}} + \frac{a \text{ pin}}{\rho \text{ in}}$$

~ B_{in} By assuming resistive dissipation, the elec
then given by
 $+ V_R) 2 \mu$

The scaling relations show that the reconnection rate is weakly sensitive to asymptotic downstream pressure

If one outflow jet is blocked, reconnection will be almost as quick

Reconnection will slow down greatly only if both outflow

jetske d

are
The current sheet responds to asymmetric downs
stream pressure by changing its thickness or length

However, this analysis makes three major assumptions :

The current sheet is stationary

The current sheet thickness is uniform

Magnetic tension contributes symmetrically
along the boundaries

To make further progress, we must do numerical simulations



—

Simulations start from a periodic Harris sheet which is perturbed at two nearby locations ($x = \pm 1$)
 Domain: $-30 \leq x \leq 30$, $-12 \leq z \leq 12$
 Simulation parameters: $\eta = 10^{-3}$, $\beta_8 = 1$, $S = 10^3 - 10^4$, $Pm = 1$, $\gamma = 5/3$, $d_0 = 0.1$

Define:

x_n is the position of the X-line

x_s is the position of the flow stagnation point

V_x is the velocity

$\frac{dx_n}{dt}(x_n)$ is the velocity at the X-line

$\frac{dx_s}{dt}$ is the velocity of the X-line

\hat{x} is the outflow direction, \hat{y} is the out-of-plane direction, and \hat{z} is the inflow direction

We show only $x = 0$ since the simulation is symmetric

In dimensionless form, the equations used for the simulations are

$$\nabla \cdot \mathbf{B} = 0 \quad (3) \quad \rho \frac{\partial \mathbf{V}}{\partial t} + \mathbf{V} \cdot \nabla \mathbf{V} = \mathbf{J} \times \mathbf{B} - \nabla p - \nabla \cdot \rho \mathbf{v} \nabla \mathbf{V} \quad (4) \quad \frac{\partial \rho}{\partial t} + \nabla \cdot (\rho \mathbf{V}) = \nabla \cdot \mathbf{D} \nabla \bar{\rho} \quad (5) \quad \rho \gamma^{-1} \frac{\partial T}{\partial t} + \mathbf{V} \cdot \nabla T = p_2 \nabla \cdot \mathbf{V} - \nabla \cdot \mathbf{q} + Q \quad (6)$$

B

$$= \nabla \times (\eta \mathbf{J} - \mathbf{V} \times \mathbf{B}) + \kappa_{\text{divb}} \nabla \nabla \cdot \mathbf{B} \quad (1) \quad \mathbf{J} = \nabla \times \mathbf{B}$$

$$-\nabla \quad (2)$$

Divergence cleaning is used to prevent the accumulation of divergence error

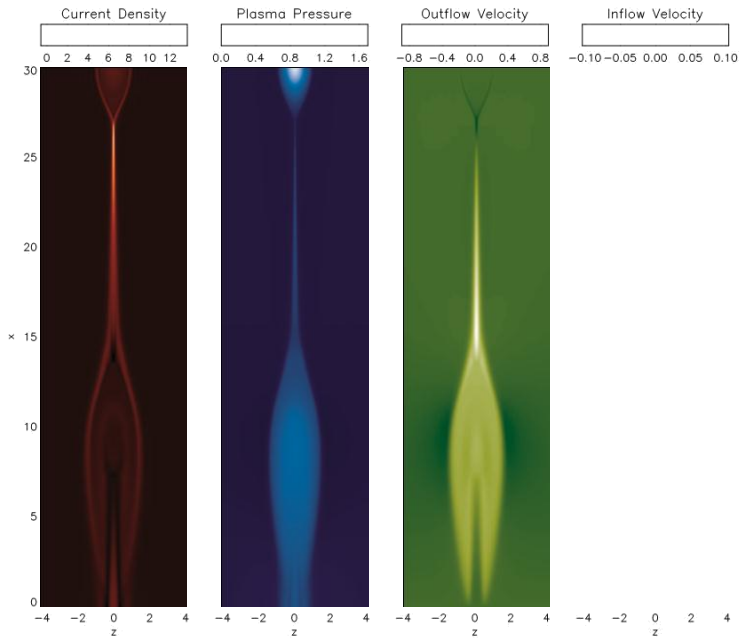

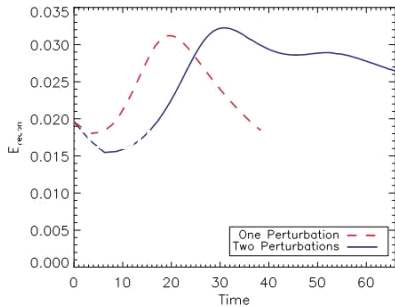
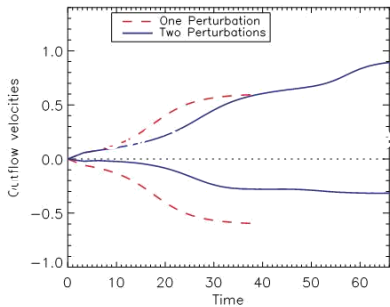

I aton (2008) and Re eve s et al. (2010), mos t of the
n energy go e s away from the obstructe d exit

a Eve nt ually, re conne ction pro cee ds m ore quickly in
g retreat sim ulations than in othe rw is e equivalent s
r ymm etric, non- re treating sim ulations

e The com parison w ith the single p e rturbation case is
e halted around $t \sim 40$ b ec ause of the formation of an is
land at $x = 0$

m
e

n
t
w
it
h

S
e

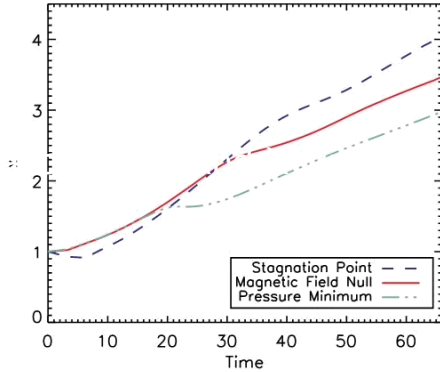

Relative positions of the X-line and flow stagnation point switch!

This occurs so that the stagnation point will be located near where the tension and pressure forces cancel

Reconnection develops slowly because the X-line is located near a pressure minimum early in time

i
n
g
l
y
,
t
h
e
r

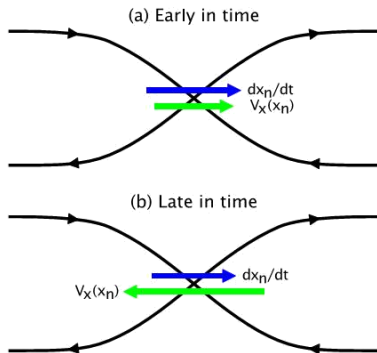
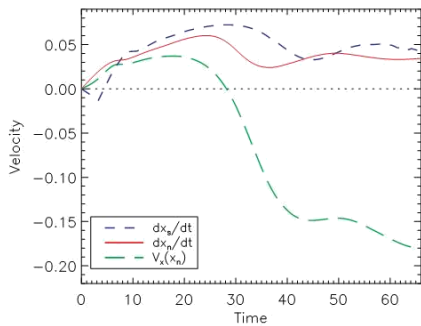

The stagnation point retreats more quickly than the X-line

Any difference between $\frac{dx_n}{dt}$ and V_x

must be due to diffusion (e.g., Seaton 2008)

The velocity at the X-line is not the velocity of the X-line



The component of Faraday's law for the 2D symmetric inflow case is

$$\frac{\partial B_z}{\partial t} = -\frac{\partial E_y}{\partial x} \quad (7)$$

The convective derivative of B_z at the X-line taken at the velocity of X-line retreat, dx/dt , is $\frac{\partial B_z}{\partial t} + \frac{dx}{dt} \frac{\partial B_z}{\partial x}$. The RHS of Eq. (8) is zero because $B_z(x_n, z=0) = 0$ by definition for this geometry.

(
z

)

c

From
Eqs. 7
and 8:
 $\frac{dx}{dt} =$

$$\frac{dx}{dt} = \frac{1}{2} \frac{d}{dt} \left(\frac{1}{x} \right) \quad (9)$$

$$\frac{\partial^2 B_z}{\partial x^2} \quad (10)$$

+

$\frac{\partial B}{\partial x}$

Using $\mathbf{E} + \mathbf{V} \times \mathbf{B} = \eta \mathbf{J}$, $\frac{\partial E_y}{\partial x} = \eta \frac{\partial^2 B_z}{\partial x^2}$

we arrive at) - $\eta \frac{\partial^2 B_z}{\partial x^2}$

In the simulations

$$\frac{\partial^2 B_z}{\partial z^2} \quad \frac{\partial^2 B_z}{\partial x^2}$$

, so X-line retreat is caused by diffusion of the normal component of the magnetic field along the inflow direction. Equation (9) can also be evaluated using additional terms in the generalized Ohm's law

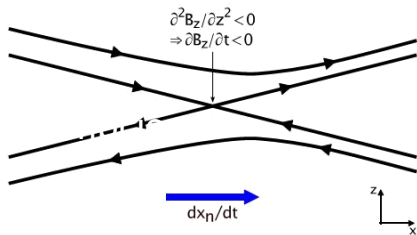

Then the direction of increasing total reconnection
helicity field strength

^e X-line retreat occurs through a combination of advection by bulk plasma flow and diffusion of the normal component of the magnetic field

⁻ X-line motion depends intrinsically on local parameters evaluated at the X-line

i
n
e

m

o
v
e
s

i

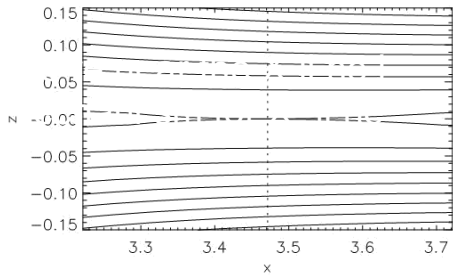
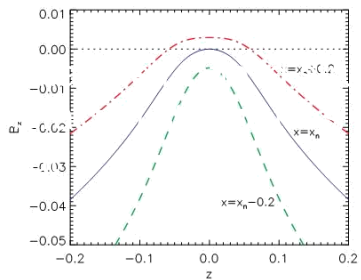

Region of the X- line

Left: $B_z(z)$ along the locations near the X-
line .

Right : Magnetic flux contours near the X-line.

gat
ive
Bz
diff
us
es
fro
m
ab
ov
e
an
d b
elo
w
int
o
the

NIMROD resistive MHD simulations with multiple initial X-line perturbations were analyzed by A. K. Young

Isolated or strong perturbations are more likely to survive

Initial X-lines surrounded by other initial X-lines are less likely to survive, but X-lines which have room to develop in one outflow direction do have a better chance of developing (see also two-fluid simulations by Nakamura et al. 2010)

Early on, winning X-lines have plasma pressure facilitating outflow rather than impeding it

When an X-line is located near one exit of the current sheet, the flow stagnation point is located between the X-line and a central plasma pressure maximum

Flow across the X-line in the opposite direction of X-line motion does occur, but infrequently

If $x_s > x_n$, then usually $V_{plasma} > 0$ (SHASTA simulations by C. C. Shen et al.)
the direction of plasma ejection is
relative locations of the flow stagnation
> 0

The induction equation is $\partial B / \partial t + \nabla \cdot \mathbf{B} = \mathbf{B} \cdot \nabla \mathbf{V} - \mathbf{B} (\nabla \cdot \mathbf{V}) + \eta \nabla^2 B$, (11)

where in our 2-D geometry $\nabla^2 = \partial^2 / \partial x^2 + \partial^2 / \partial z^2$. (12)

The term $\eta \partial^2 B / \partial x^2$

acts to smooth profile. This term can move or reduce the number of
cut the $B_z(x)$ X-lines (where $B_z = 0$), but not create new X-lines.

The term $\eta \partial_z B_z$ brings in

$\eta \partial_z B_z$ B_z

along the inflow direction. This term can move or increase the number of X-lines, but by symmetry cannot cause pre-existing X-lines to disappear.



X-line motion occurs frequently during reconnection in space, astrophysics, and the laboratory

Resistive MHD simulations of X-line retreat/asymmetric outflow reconnection show that most of the energy is directed away from the obstructed exit

Late in time there is significant flow across the X-line in the opposite direction of X-line retreat

An expression for the rate of X-line retreat shows that X-line motion is due to either advection by the bulk plasma flow or by diffusion of the normal component of the magnetic field

Simulations of multiple X-line reconnection show that:

- Initial X-lines with room to develop on at least one side are more likely to survive

The flow stagnation point is typically located between the X-line and a central plasma pressure maximum

Sim
ulation:

T ulations of X-line re tre at

w 3-D sim ulations of X-line retreat with initial p

o erturbations offs et from each other in the out -of- plane
- direct ion

fl Examine X- line b e havior during the plasm oid inst
u ability

i d Inv estigate X- line dynamic s in two and thre e dim ensions
s for realis tic geome tries such as c oronal jets , CME c
i urrent s he ets , planetary m agnetot ails, and sphe rom ak
m me rging e xp e rim ents

Inv estigate X- line mot ion in asym me tric inflow re
connec tion

The

ory:

De rive e xpre ssions for neutral line and X-line m otion in
3-D

De termine the rat e of re tre at of the flow st agnation p
oint

Examine the c ons eque nces of a se parat ion b etwe
en 3-D magnetic field nulls and flow s tagnation p oints

Experiment and observation (suggestions for others):

Characterize X-line motion during laboratory reconnection

Find signatures of X-line retreat in magnetotail (M. Oka)

Observe effects of asymmetric outflow in CME current sheets